

## MODELING AND OPTIMAL CONTROL OF REACTIVE POWER IN A MICROGRID USING DOUBLY FED INDUCTION GENERATOR

Mohsen KAZEMI ALAMOUTI  
K.N. Toosi University of Tech – Iran  
M\_kazemi@ee.kntu.ac.ir

Masoud ALIAKBAR GOLKAR  
K.N. Toosi University of Tech – Iran  
Golkar@eetd.kntu.ac.ir

Shokrollah SHOKRI KOJOORI  
K.N. Toosi University of Tech – Iran  
shokri@kntu.ac.ir

Mohammad Amin SALMANI  
MAPNA Group – Iran  
Salmani\_M@mapna.com

### ABSTRACT

*In this paper a novel methodology for modeling and control of reactive power in microgrid is proposed. This structure uses wind turbine driven doubly fed induction generator (DFIG). Accordingly, a model is offered to describe the dynamics of voltage and reactive power of DFIG and synchronous generator. Afterwards, by minimizing a cost function based on particle swarm optimization (PSO) method, a control system is designed for the microgrid reactive power. The control strategy is applied to the system for local compensation of reactive power in islanding operation mode. At the end, simulation results provide a basis to illustrate the efficiency of the proposed method and its significant impact on microgrid dynamic behavior.*

### INTRODUCTION

Because of increase in energy demands and decrease in fossil fuel resources, renewable energies are considered as the best way to compensate lack of power. This leads to diminish the concern of pollution and unfavorable environmental impacts of fossil fuels. Microgrid, as an active distribution network, includes distributed generation (DG) and different loads at distribution or sub-transmission voltage levels. Hence, it needs suitable control strategy to present itself as a single controlled power unit [1]. By using microgrids, generated power at distribution voltage can be directly fed to the utility distribution network. Also, loads can be efficiently supplied with satisfactory voltage and frequency profile, and negligible line losses [2]. Nowadays, wind power is widely in use because of its clean energy and zero fuel cost. One of the most important challenges of wind power systems with induction generators especially in microgrids or isolated networks is their variable reactive power requirements at different wind speeds. Capacitor banks or power electronic-based reactive power sources like SVCs have been widely used to meet these requirements [3]-[4].

Usage of DFIGs in wind power systems as one of the renewable energy resources is increasing rapidly. It's because of their variable operation speed for maximum power tracking, decoupled active and reactive power

control, lower converter costs, and their capability to keep the voltage constant when generator works at different speeds [5].

In this paper, a novel system structure is described as a microgrid using DFIG. After that, a new mathematical model according to reactive power balance equation is demonstrated for the system. Then the state space model of the system reactive power is achieved. In order to find the suitable values for PI controller, the particle swarm optimization (PSO) algorithm is applied to a proper objective function. Indeed, considering the voltage dynamics of the point of common coupling (PCC), the PI parameters are tuned. It shows that diesel generator set and DFIG can cooperatively provide the load reactive power requirements with proper sizing of the DGs.

The rest of this paper is organized as follows. The next section is dedicated to the microgrid system. Thereafter, the reactive power dynamics is modeled and represented in the state space framework. Next, controller design description is addressed. After computer simulations, the conclusions are recounted.

### MICROGRID CONFIGURATION

Figure 1 shows the schematic diagram of the microgrid system including loads and DG units.

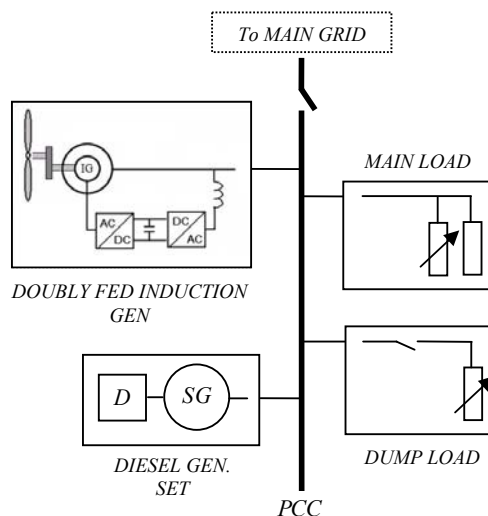

Figure 1: Microgrid schematic diagram

DFIG is a wounded rotor asynchronous generator. In this generator the power flowing between the rotor and grid must be channeled by use of AC/DC/AC converters as it shown in Figure 1.

Vector control is applied to enable power flow control through converters. The objective of supply side converter is to keep the DC-Link voltage constant without considering the direction of the rotor power flow [6]. The induction machine is controlled in synchronous rotating  $dq$  axis frame based on the stator flux vector position. So the decoupled active and reactive power control is achieved by controlling the  $I_{qr}$  and  $I_{dr}$  through rotor side converter [5].

Moreover, the synchronous generator driven by diesel engine as a conventional DG unit is used to regulate active and reactive power in low wind speed or high load demand. For frequency regulation in high wind speeds a discrete dump load system is used.

## REACTIVE POWER MODELLING

In order to attain the dynamic model of the microgrid reactive power, the effect of total reactive power production and consumption inequality on voltage profile is shown. Thus, linearized equations of the system are presented as well.

### Total reactive power balance

In order to guarantee the voltage stability, the supply and demand of reactive power should be balanced. The reactive power balance under the steady state condition is stated as

$$Q_{SG} + Q_{DFIG} = Q_L \quad (1)$$

where

$Q_{SG}$  = reactive power generated by diesel generator set

$Q_{DFIG}$  = output reactive power of DFIG

$Q_L$  = load reactive power

The net reactive power surplus of the system will affect the system voltage by increasing the electromagnetic energy absorption  $E_M$  of the induction generator at the rate  $dE_M/dt$  and raising the reactive load consumption of the system [3] and is given by

$$\Delta Q_{SG} + \Delta Q_{DFIG} - \Delta Q_L = \frac{d(\Delta E_M)}{dx} + D_V \Delta V \quad (2)$$

As a result, by change in load reactive power, the excitation system of synchronous generator and the voltage loop PI controller of asynchronous generator detect the voltage variations. So the controllers must be tuned to generate suitable signal for compensating the extra reactive power of the load.

By using Laplace transform, (2) can be rewritten as

$$\Delta V(s) = \frac{K_V}{1+sT_V} [\Delta Q_{SG}(s) + \Delta Q_{DFIG}(s) - \Delta Q_L(s)] \quad (3)$$

where  $T_V$  and  $K_V$  have been introduced in [3]-[7].

### The DFIG equations

In DFIGs, the output Reactive power is controlled through two separate PI controllers. The outer loop compares the voltage of generator with the reference voltage to produce the input signal of its PI controller [8]. The dependence of produced reactive power of DFIG on the direct axis component of rotor current based on decoupled control in stator flux reference frame is represented as

$$Q_{DFIG} = \frac{L_m V_t}{L_{ss}} I_{dr} - \frac{V_t^2}{\omega_s L_{ss}} \quad (4)$$

the linearized format of which is rewritten as

$$\Delta Q_{DFIG}(s) = K_3 \Delta I_{dr}(s) + K_4 \Delta V(s), \quad (5)$$

where

$$K_3 = L_m V_t / L_{ss} \quad (6)$$

$$K_4 = L_m I_{dr} / L_{ss} - 2V_t / (\omega_s L_{ss}) \quad (7)$$

The rotor  $d$ -axis reference current, the output signal of the voltage loop PI controller, is given by

$$\Delta I_{dr}^{ref} = (K_p + \frac{K_I}{s}) [\Delta V^{ref}(s) - \Delta V(s)] \quad (8)$$

According to [9]-[10], an over damped second order system can be modeled with a first order system with the same settling time, so the dynamic of inner loop can be modeled by

$$\Delta I_{dr} = 1 / (1 + \frac{t_s}{4} s) \Delta I_{dr}^{ref} \quad (9)$$

The above equations illustrate the reactive power dynamics of DFIG block shown in Figure 2.

### The synchronous generator equations

The second significant block of microgrid, shown in Figure 2, is synchronous generator. The equations of this section is

$$\Delta Q_{SG}(s) = K_1 \Delta E'_q(s) + K_2 \Delta V(s) \quad (10)$$

Also, its flux linkage can be written as

$$(1 + sT_G) \Delta E'_q(s) = K_5 \Delta E_{fd}(s) + K_6 \Delta V(s) \quad (11)$$

where  $K_1, K_2, K_5, K_6$  and  $T_G$  are defined in [3].

The IEEE type-I excitation system model is utilized to produce the proper field voltage for the synchronous generator.

### State space model of microgrid reactive power

In order to design suitable controller, a state space representation for the system dynamics is utilized. The standard state space equation is

$$\dot{\underline{x}} = A\underline{x} + B\underline{u} + B_1\underline{w} \quad (12)$$

$\underline{x}$ ,  $\underline{u}$  and  $\underline{w}$  are state, control and disturbance vectors of the proposed system given by

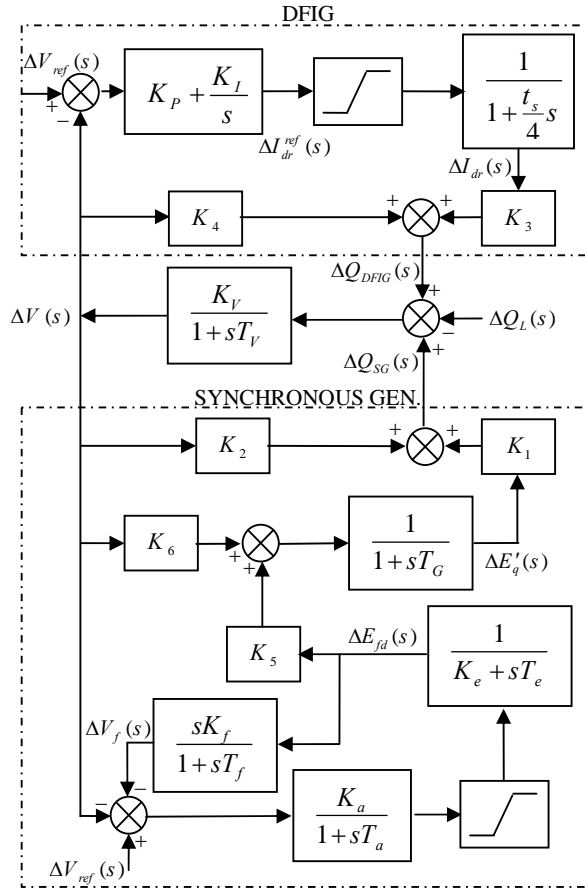

Figure 2: Block diagram of reactive power control system

$$\underline{x} = [\Delta I_{dr}^{ref}, \Delta I_{dr}, \Delta V, \Delta E'_{fd}, \Delta V_a, \Delta V_f, \Delta E'_q]^T \quad (13)$$

$$\underline{u} = [\Delta V^{ref}] \quad (14)$$

$$\underline{w} = [\Delta Q_L] \quad (15)$$

and A, B, and B<sub>1</sub> are matrices of appropriate dimensions. Figure 2 shows the block diagram of reactive power control in the microgrid system.

## CONTROLLER DESIGN

In order to attain certain performance specifications while keeping the system stable, PI parameters tuning is necessary. To keep the voltage on its pre-specified reference and minimizing its fluctuations, a cost function based on Minimum Integral Square of the voltage variations considered as

$$J_1 = \int [\Delta V(t)]^2 dt \quad (16)$$

Also, to reduce the overshoot of rotor current when a disturbance occurs in load reactive power  $J_2$  is introduced as follow

$$J_2 = (\Delta I_{dr}^{ref} - \Delta I_{dr}^{ref}) / \Delta I_{dr}^{ref} \quad (17)$$

which  $\Delta I_{dr}^{ref}$  and  $\Delta I_{dr}^{ref}$  are maximum and steady state values of the rotor  $d$ -axis current respectively.

Achieving suitable tradeoff between aforementioned objective functions the performance index function is considered as

$$J_t = \overline{J}_1 + \overline{J}_2 \quad (18)$$

in which  $\overline{J}_1$  and  $\overline{J}_2$  are the assignments of  $J_1$  and  $J_2$  to  $[0, 1]$  on the basis of

$$\overline{J}_n = (J_n - J_n^{\min}) / (J_n^{\max} - J_n^{\min}), n = 1, 2 \quad (19)$$

In order to minimize this objective function, PSO algorithm is employed because of its efficiency.

## SIMULATION AND RESULTS

Table 1 shows the rated capacity and system parameters. Choosing the generators appropriate nominal capacity and microgrid operation point is essential. This is because of limitations on DFIG reactive power and diesel generator power factor in the steady state conditions. These limitations are considered in this paper, and their values are shown in Table 1.

Table 1: Nominal capacity and system parameters

DFIG=1.67 MVA	$L_{ss}=3.071 pu$ $H_r=0.62 sec$	$L_m=2.9 pu$ $T_s=0.08 sec$	$I_{dr}=0.42 pu$
DieselGen.Set =2 MVA	$X'_d=0.296 pu$ $T_e=0.55$	$X_d=1.56 pu$ $K_e=1$	$\delta=27.8^\circ$ $T_f=0.715$
$K_f=0.5$	$T_a=0.05$	$K_a=40$	$T'_{do}=4.49 sec$
$S_{base}=2 MVA$	$V^{ref}=1 pu$	$Q_L=0.2 pu$	$q=2$
$Q_{DFIG}=0.125 pu$	$pf_{SG}=0.95$		

The optimum values of the PI parameters, corresponding to the minimum value of the total objective function, are calculated when  $0.01 pu$  step increase in reactive power of load occurs. PSO algorithm is utilized to derive the PI parameters based on the total objective function and the system model. In this simulation 30 particles with 2000 iterations are considered.

As a result the optimal values of the PI parameters which minimize  $J_t$  are  $K_p=8.61$  and  $K_I=172.2$ .

Figure 3 shows that voltage oscillations are manipulated correctly and the system has the ability to keep itself stable in presence of load disturbances and different wind speeds. Also, Figure 3 shows the rotor current is regulated correctly to compensate the load reactive power variations. It should be noted that duration of oscillations directly depends on inertia constant of the induction machine.

As it is illustrated in Figure 4, DFIG and synchronous generator have the ability to compensate the load reactive power variations.

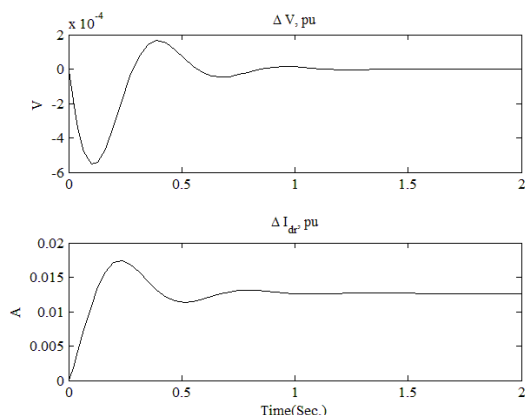

**Figure 3: Response of system voltage and rotor d-axis current to 0.01 pu step increase of load reactive power.**

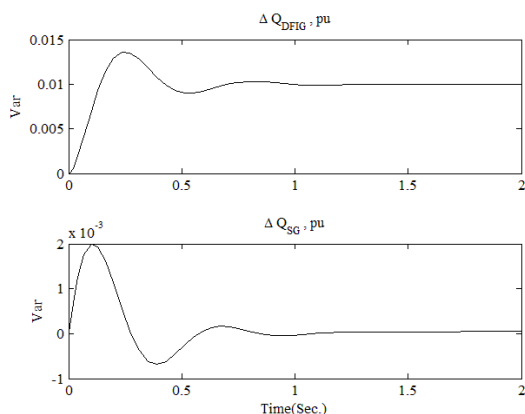

**Figure 4: Response of DFIG and Diesel Gen. Set output reactive current to 0.01 pu step increase of load reactive power.**

## CONCLUSION

In this paper a dynamic model of reactive power control system in microgrid using DFIG is suggested. The emphasis in this paper is on utilizing the DFIG reactive power capability to improve the voltage dynamic of microgrid in isolated mode of operation. Consequently, a new control strategy is offered to manage the reactive power of microgrid system. Using a proper objective function and PSO method the control parameters were tuned. This led to a tangible enhancement of the system performance by minimizing the voltage fluctuations and rotor current overshoot. The presented results accounted that the DFIG-based microgrid system provides a complete base for local load supply. Finally the efficiency of the introduced system was demonstrated through a computer simulation.

## Acknowledgments

The study presented in this report has been financially supported by Iran Power Plant Projects Management

(MAPNA) Group.

## REFERENCES

- [1] S. Chowdhury, S.P. Chowdhury and P. Crossley, 2009, *Microgrids and Active Distribution Networks*, IET, London, United Kingdom, 122-127.
- [2] F. Katiraei, M.R. Iravani, "Power Management Strategies for a Microgrid with Multiple Distributed Generation Units", *IEEE TRANSACTIONS on Power Sys.* Vol. 21, NO. 4, November 2006
- [3] R.C. Bansal, 2008, "Modeling and automatic reactive power control of isolated wind-diesel hybrid power systems using ANN", *ELSEVIER Energy Conversion and Management.* 357– 364.
- [4] R. Sebastian, R. Pena Alzola, 2009, "Effective active power control of a high penetration wind diesel system with a Ni–Cd battery energy storage", *ELSEVIER Renewable Energy*, 952–965.
- [5] L. Zhang, X. Cai, and J. Guo, 2009, "Simplified Input-Output Linearizing and Decoupling Control of Wind Turbine Driven Doubly-Fed Induction Generators", *IEEE IPEMC 2009*, 978-1.
- [6] R. Pena, J.C. Clare. G. M. Asher, 1996, "A doubly fed induction generator using back to back PWM converters supplying an isolated load from a variable speed wind turbine", *IEE Proc. Elec. Power Appl.* Vol. 143. No. 5
- [7] N. Miller, W. Price, J. Sanchez-Gasca, 2003, "Dynamic Modeling of GE 1.5 and 3.6 Wind Turbine-Generators", *GE-Power Systems Energy Consulting*, Version 3.0
- [8] J.P.A. Vieira, M.N.A. Nunes, U.H. Bezerra, 2008, "Design of Optimal PI Controllers for Doubly Fed Induction Generators in Wind Turbines Using Genetic Algorithm", *Power and Energy Society General Meeting IEEE*, Pittsburgh, PA, 1 – 7.
- [9] B.C. Rabelo, W. Hofmann, J.L. da Silva, R.G. de Oliveira, S.R. Silva, 2009, "Reactive Power Control Design in Doubly Fed Induction Generators for Wind Turbines", *IEEE TRANSACTIONS Ind. Elec.* VOL. 56, No. 10
- [10] G. Tapia, A. Tapia Otaegui, 2005, "Wind generation optimization algorithm for a doubly fed induction generator", *IET Generation, Transmission and Distribution.* vol. 2, 253 - 263.