

NEW PROTECTION CONFIGURATION FOR HIGH QUALITY MV RING DISTRIBUTION SYSTEMS

Morris BRENNNA, Federica FOIADELLI, Dario ZANINELLI
Politecnico di Milano - Italy

morris.brenna@polimi.it, federica.foiadelli@polimi.it, dario.zaninelli@polimi.it

Donato LOMBARDI
EnergyLab Foundation - Italy

donato.lombardi@energylabfoundation.org

ABSTRACT

This paper deals with the protection coordination in particular distribution system, such as hospitals, characterized by the need of high quality energy supply. In the paper, after a brief description of the network schemes and of the selectivity concept, the real case of a hospital whose system had big selectivity problems is discussed. Finally, the paper presents a possible solution to this problem, supported by a correct application of the Italian standard CEI 0-16 and a deeply selectivity study.

INTRODUCTION

An electric system can be subjected to faults, as short-circuit among phases, line-to-ground fault or overload of the lines. This situation leads to exclude as soon as possible the interested element in order to prevent other damages. A right selectivity consists in the protection coordination in order to eliminate only the faulted branch or device from the system, letting the functioning of the remaining part.

In particular electric systems, such as the hospital one, supply interruptions are not tolerable, most of all for those devices that are indispensable for the life of the people.

The paper presents a real case of a hospital whose system had big selectivity problems. The worst selectivity problems were on the MV network regarding the protection times imposed by the new distributor, substitute of the national one after the market liberalization. The immediate solution was to manage the MV network in a temporary asset: in fact the normal hospital network at 20 kV was designed for a close ring operation, but actually it is temporary managed at opening ring to overcome the selectivity problems. The paper presents a possible solution to this problem, supported by a correct application of the Italian standard CEI 0-16 and a deeply selectivity study.

ELECTRICAL SYSTEM PROTECTION

One of the most important thing in the electric system planning is the protection coordination or selectivity study that wants to assure the system security without impairing with its continuity. In fact, in case of fault or overload of an electric network element, only that element has to go out of order. The technical criteria for the users connection to the a.c. electric networks at nominal voltage between 1 kV and 150 kV are defined by the CEI 0-16, valid since 2008. Such standard is applied to the electric energy distributor and to the electric systems of the distribution services users. The MV network protection is guaranteed at least for the short circuit, the overload and the fault to ground, but the

distributor's protection do not protect the users plants. For this reason the user has to install protection systems for its own plant. Before studying the selectivity of the system, it is necessary to consider its typology, in fact different networks schemes can be adopted basing on the continuity needs, costs and future evolutions of the system.

The present work considers a MV network and two possible configurations: the star and the ring topologies. In the star networks a peripheral overload condition means a difficult functioning of a part of the network, worsening the supply conditions of the all net loads. The absence of a possible loads compensation implies the difficulty to amply the network. On the contrary the ring topology, with one or more supply, is often used in parts of MV networks to supply big loads that need continuity. This topology lets to always have two supply for each system station, because it presents at least one line more than the minimum needed to connect the loads to the supply node. The ring topology permits a better loads distribution and then a better functioning security with respect to the star nets.

It is also important to consider the neutral conductor management, that changes following the connection between neutral and ground. In Italy, the neutral directly grounded is used for the HV networks in order to avoid the overvoltages, while in the MV networks the neutral is isolated to contain the high currents. However since 2000 in all the national network the neutral status is changing introducing the grounded via Petersen coil.

Considering the MV distribution ring scheme of the hospital, the interface between the user and the distributor is the general disposal (DG). The DG assures the separation of the whole user plant from the network, because it is a sectioning disposal and its opening is imposed by the general protection system (SPG). Therefore the SPG is the protection system related to the DG. This system, opportunely coordinated with the line protections of the distributor that communicates the right regulation data, must help in the searching of the elements that are out of order and in their exclusion. In the protection coordination study, particular attention is for the right protection timing. There are different selectivity criteria that can be used in the networks, such as the chronometric, amperometric, energetic, zonal, logic. In order to realize the selectivity in a ring network, it is necessary to combine the different selectivity and to create dedicated protection systems. Two different techniques for the fault individuation can be used: the differential protections (for phase faults and directional ground protections for internal faults) and the maximum

directional current protections (for both phase and ground faults). It is necessary to install pilot threads among the various lines relays to reach the right selectivity. Considering that the use of differential protections for long lines and complex networks is generally too expensive, only the second solution (directional phase and ground protections) is used. For the ring networks functioning, it is necessary to considerate the difficulty to rightly individuate the ground faults in function of the net neutral status and of the regulation of the upstream protections. This is particularly true for the distribution ring connected to ground with small fault currents. If the ring is used opened, it is the same case of a star network and consequently it is possible to use a chronometric or logic selectivity, adopting normal maximum current protections (eventually directional protections for faults to ground if the capacitive contribute is high).

A REAL CASE: THE HOSPITAL MV NETWORK

This paper considers a real hospital system that presented selectivity problems. A hospital has to guarantee the functioning of all the necessary services and therefore it is important to achieve a good continuity of the electric service. Considering the electric power distribution the hospital has two different ring MV distribution networks: one is a normal supply network at 20 kV that connects all the stations (the supply station CC of the first distributor and the other three MV/LV stations C1, C2, C3) and the other one is a reserve network at 6 kV, supplied from the emergency system, that connects the stations C1, C2 and C3. The first network was projected to work as close ring with automatic individuation of the fault and exclusion of the damaged line. However, for selectivity problems with the distributor line protection, it has been realized as open ring between the stations C1 and C2. The MV ring is depicted in Figure 1. The second network is managed at open ring between the stations C2 and C3 with manual restoring in case of fault.

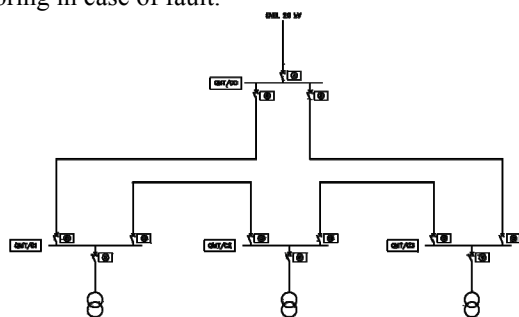

Figure 1: MV hospital distribution ring scheme

Both the networks start in the same point, where there are the supply station CC and the transformation supply station C1 that contains the reserve group. Moreover, there is another supply point derived from the old connection with the first distributor, realized in a way that is not possible to

work in parallel with the main supply. This reserve supplies the hospital in case of malfunctioning or maintenance of the CC station, letting the total bypass of this station. In this way the supply from public network is guaranteed even if the hospital has not a dedicated line. As above described, the normal network at 20 kV of the considered hospital was projected to work as close ring. The protections installed are the ones reported in Figure 2(a). Each starting and arriving of the lines that connect the ring stations are provided with maximum current directional (67) and zero-sequence maximum current directional (67N) protections. The other protections reported in Figure 2(a) and (b) are the instantaneous phase and ground maximum current relays (50 and 50N), and the delayed phase and ground maximum current relays (60 and 60N). There are also protections for overloads and overcurrents but they are not shown in the Figure 2(a). At the moment the normal MV network at 20 kV is managed as open and therefore the line between the station C1 and C2 is not considered, creating a star network with two lines: one that supplies the station C1 and one that supplies the stations C2 and C3, as depicted in Figure 2(b).

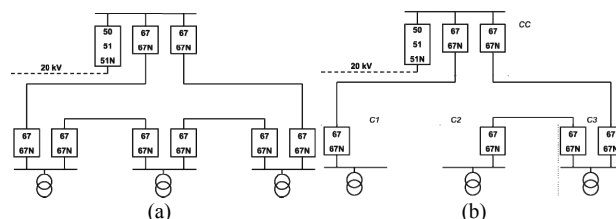

Figure 2: 20 kV MV network protections (a) of the starting project and (b) of the actual configuration

This configuration lets to manually reconsider the network in case of fault on an active line, supplying the station from the opposite side once that the line between C1 and C2 usually inactive is inserted. However, the manual reconfiguration does not permit to supply again the station in short times and then the emergency generators have to work helping the UPS necessary for the vital disposal of the hospital. The selectivity problem deals with the short-circuit protection, which maximum starting time is 0.12 s. The time of the ground directional at compensated neutral (67.1) equal to 0.45 s lets to intervene the user protection before of the line protection of the distributor. There is a problem with the ground directional if the network is managed with isolated neutral: in this case the time for the 67.2 is equal to 0.17 s, not enough for the chronometric selectivity. In the considered system a pilot thread between the ring directional protections is installed but it is not activated; the thread is not installed to DG. The necessity to have only one DG, as defined in the standard DK5600 of the first distributor, implies the DG downstream protections regulation with times even shorter than the limits imposed by the second distributor for the DG. For the protection against short-circuits, which regulation is imposed equal to 0.12 s, it is not possible to obtain the selectivity with the other user protections, causing the out of order of the whole

hospital in case of fault. The supply is possible only after a manual opening of the fault line by the technicians, comporting too long times covered by the emergency supply.

THE SELECTIVITY PROBLEM OVERCOMING

The system scheme proposed presents a two MV uprights, instead of the general solution with one upright. The double upright scheme, that is particularly adapt for the ring networks, lets to modify the connection, eliminating the selectivity step between the DG and the ring start and letting to have directly the two starts as DG. The proposed solution is reported in Figure 3.

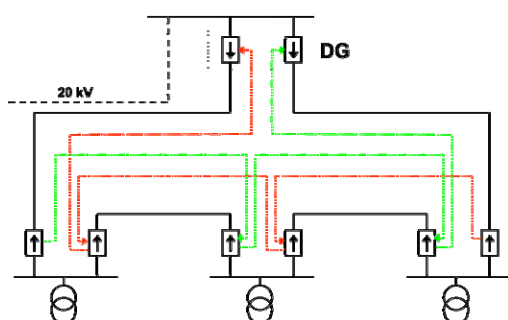

Figure 3: Solution proposal with two MV uprights following the CEI 0-16 standard

In this new configuration the calibrations imposed by the new distributor are not regulated upstream the ring starts, but they are directly regulate at the ring starts. In this way it is possible to eliminate a selectivity step without implementing other modifies such as installing another pilot thread on the starts and on the DG. In fact the last circuit breaker that requires to be opened is one less, introducing a gain on the limit time. In the following paragraph a verify of the proposed solution is carried out, considering both the short-circuit and the fault to ground case on the MV network.

Short-circuit on the MV network

In case of short-circuit the protections to be considered are the directional maximum current protection 67. In order to study the protections behaviour, faults on the ring lines among the stations have been simulated, beginning from a ring start to the other one, in order to cover the all cases. For conciseness reasons, only the case of fault on the line between CC and C3 is reported as an example. In this case, the fault current will flow in the network as shown in Figure 4(a). The protections that feel the fault and can function are the ones with the same direction of the current. As described in the CEI 0-16, the MV protections can see the fault, individuate the current direction and send the stop signals in 100 ms. The physical opening of the circuit breaker needs 70 ms. Using these values, the logic selectivity signal dispatch through the pilot thread uses the 100 ms. In this case, the upstream protections that send the stop signal are represented in Figure 4(b) and lead to the

real intervention of the only highlighted protections.

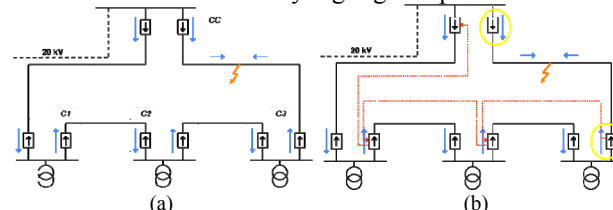

Figure 4: (a) Fault currents relating to a fault on the branch between CC and C3 and (b) protections that really work after the stop signals dispatch.

The protections nearest the fault open after the delay of 100 ms, and in 70 ms the faulted line is isolated. In 170 ms the reconfiguration of the radial network is done and the functioning can follow. From the analysis conducted on the different rings, it is possible to conclude that the realized protections let to isolated the MV faulted line in 170 ms, letting the normal functioning of the system after the opening of the distributor line protection and the first automatic reclosing (equal to 0.6 s). The fault can be repaired with the hospital system working. To arrive to the final solution it is also necessary to consider the cases of faults on the MV half busbars of the MV/LV stations, instead of on the connection lines. In this case it is necessary to proceed trying to arrive to a more deeply selective coordination level.

The proposed solution consists in the hypothesis to regulate the REF542plus used as directional disconnector (of maximum short-circuit current) and it is possible to program the behaviour based on the fault current direction flowing in the disconnector. Realizing the connection with the pilot thread of the directional protections it is possible to use the logic of the disconnector as the one of the directional protections of the ring lines. In this way, based on the fault current direction, the disconnector sends the stop signal on a thread of one direction or the other one.

The disconnector, in function of the current direction, becomes a protection composed by the directionals that insist on the same versus and let to discriminate the stop signal dispatch to the upstream protection. Therefore it is possible to open the protections nearest the fault in 100 ms and only the faulted half busbar is isolated in 70 ms. Also in this complex case, the network is reconfigured in star typology in 170 ms with the change of the transformer that supply the C2 station users.

The hypothesized solution lets not to have the complete exclusion of the whole station C2, but to maintain the supply from the distributor network also in case of fault inside the station. The complete add of the new pilot threads for the disconnectors is shown in Figure 5. This is the complete and correct solution to guarantee the better functioning continuity in case of faults wherever in the MV network. This solution lets to have the logic selectivity of every MV network faults in 170 ms. With the distributor intervention times and with this configuration, in case of fault inside the MV hospital network, there will be the

distributor line protections intervention, but also the one of the hospital protections in 0.17 s.

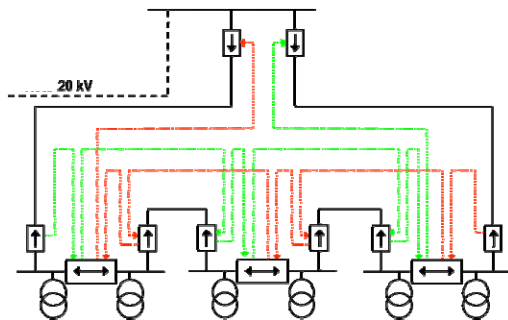

Figure 5: Complete scheme of the solution proposal with MV double uprights following the CEI 0-16.

In this way the consequently reclosing of the distributor will find the network without fault and the normal functioning will start. Therefore the other users of the same MV hospital line will have an interruption of only 0.6 s.

Fault to ground on the MV network

In order to verify the proposed solution validity, the same analysis performed for the short-circuits has been conducted for the faults to ground. Always for brevity reasons, only the conclusions are reported in the following lines.

The proposed double upright scheme has a problem regarding the fault to ground.

The ring departures have maximum zero-sequence current directional protections and consequently a possible unbalance, due to the normal functioning or to a MV network constructive difference, can lead to a positive differential current flow in a branch and a negative one in the other branch with an untimely working of the 67N protection also without fault. A possible solution is to insert upstream of the two departures another ground protection 51N, that would see the two unbalances sum and then would not feel any dispersion current. The connection of the 51N with the 67Ns of the departures with regulation AND would lead to the working of the 67Ns only if the upstream 51N feels a fault current. This means that the 67Ns would intervene only for a real fault to ground. This problem is more important in the compensated neutral networks, as the one to which the hospital is connected, because the 67N limit is equal to 2 A, while with isolated neutral is equal to some tens of Ampere. In the particular case of the considered hospital, the problem can be easily solved without other installations by the activation of the ground protection on the REF452plus. This last substitutes the DG in the actual configuration but is used only as sectioning in the proposed solution, connected to the two departures with the pilot thread that dispatches the logic selectivity signals. The performed study shows that the so realized protections let to isolate the faulted MV network branch in 170 ms, permitting the normal hospital system functioning after the distributor line protections intervention and the first automatic reclosing.

It is possible to conclude that the proposed solution lets the logic selection of the MV network faults in 170 ms also for the fault to ground. However, in this case the intervention time requested by the distributor for the faults to ground with compensated neutral is equal to 0.45 s. Therefore, the line protections do not intervene for the fault to ground and the normal functioning automatically restarts thanks to the hospital network protections coordination.

CONCLUSIONS

The work carried out has considered the importance of the electric protections coordination to guarantee a good coordination maintaining the energy continuity.

The connection to the primary distribution network is always critic, because the public distributor protects only its lines from the overloads, short-circuits and faults to ground and not the user system. Therefore the private has to protect its system but following the conditions defined by the distributor in order to guarantee security to all the users connected to the same line and contemporary a better quality of the electric service.

The paper has considered the primary distribution system in a real hospital that presented problems related to protections coordination. A real solution proposed to solve these problems considers the use of a primary distribution network with the close ring configuration. The proposal, that is in accord with the Italian standard CEI 0-16, consists in the directional protections use both for the beginning and for the disconnectors of the stations, that are coordinated with a logic selectivity. This solution has been tested and validated through simulations carried out on the real system in which the protections functioning respects the times imposed by the distributor.

REFERENCES

- [1] M. E. Valdes, C. Cline, S. Hansen, T. Papallo, "Selectivity Analysis in Low-Voltage Power Distribution Systems With Fuses and Circuit Breakers", *IEEE Transactions on Industry Applications*, 2010, Volume: 46, Page(s): 593 – 602;
- [2] J.-A. Jiang, Ching-Shan Chen, Chih-Wen Liu, "A new protection scheme for fault detection, direction discrimination, classification, and location in transmission lines", *IEEE Transactions on Power Delivery*, 2003 Volume: 18, Issue: 1, Page(s): 34 – 42;
- [3] V. E. Wagner, "Reliability and cost comparison of power distribution configurations", *Industrial and Commercial Power Systems Technical Conference*, 2008, Page(s): 1 - 8
- [4] *IEEE Recommended Practice for Electric Systems in Health Care Facilities*, IEEE Std 602-1996 [The White Book], Publication Year: 1997
- [5] Italian Standard CEI 0-16, 02/2008, second edition 07/2008, "Reference technical rules for the connection of active and passive consumers to the HV and MV electrical networks of distribution Company".