

## RENEWABLE ENERGY FED INTER-LINE DVR FOR VOLTAGE SAG MITIGATION IN DISTRIBUTION GRIDS

Ahmed HOSSAM-ELDIN  
Alexandria University – Egypt  
hossamudn2009@yahoo.com

Ahmed ELSEROUGI  
Alexandria University – Egypt  
abbas\_zone@yahoo.com

### ABSTRACT

*Two-line Interline Dynamic Voltage Restorer (IDVR) consists of two back-to-back Dynamic Voltage Restorers (DVRs) connected to independent distribution feeders with a common DC link. One of the involved feeders is feeding a critical load (critical feeder). When this critical feeder is subjected to voltage sag, its DVR will compensate this sag via voltage injection (voltage control mode). The voltage control mode may absorb active power from the DC link, so the other DVR will be responsible for maintaining a constant DC link voltage via pumping the required active power into the DC bus (power control mode). The maximum active power can be pumped from the healthy feeder is mainly depend on its load displacement factor. So, if the pumped power is not sufficient, the voltage restoration will fail. This paper suggests adding renewable energy sources as a support to this system, which may be coupled across the DC link to share, if needed, in supplying the required active power during voltage sag problem. Complete analysis supported with simulations is presented in this paper.*

### NOMENCLATURE

DVR	Dynamic voltage restorer
PCC	Point of common coupling
$V_{inj}^*$	Reference of injected voltage
$V_S, V_{Load}$	Supply voltage and load voltage
$V_{inj}$	Injected voltage
$I$	load current
$\beta$	Phase difference between $\bar{v}_s$ and $\bar{v}_{Load}$
$\varphi$	Load displacement factor angle
$V_{dc}$	DC link Voltage
$V_{dc}^*$	Reference of the DC voltage
$P_S, P_{load}$	Supply power, Load power
$V_{oc}$	Open circuit voltage
$P_{ex}$	Pumped power from neighbor feeder
$P_{extot}$	Total required power for voltage restoration
$P^*$	Reference power

### INTRODUCTION

Voltage distortion in the power supply emanates from a variety of events ranging from switching events at the end user facility to faults on the transmission line. The types of power quality problems are considerably dependent on the location, if a load is located at the end of over loaded

feeder, under voltage problems will be dominant. Startup of large motors causes voltage sag, which draws very high starting currents.

Remote faults can be considered the main reason behind the voltage sag problem in a distribution system because during faults the bus voltages in the supply network are depressed; severity is dependent on the distance between each bus and the fault point. The bus voltages return to their new steady state values after clearing the fault, i.e. the fault will cause voltage sags all over the network but cause blackouts to small portion.

Due to the increase in using equipment that is sensitive to voltage variations, the voltage sag problem becomes one of the important power quality problems. Dynamic Voltage Restorers (DVRs) [1-4] are a very effective series compensation device for voltage sag mitigation.

The DVR is a voltage source inverter (VSI) which is inserted in series between the supply and a critical load. The basic operating principle of the DVR is to inject an appropriate voltage in series with the supply through an injection transformer to restore the supply voltage in abnormal conditions [5]. Energy storage units in DVRs are responsible for supplying the active power component needed during voltage sag mitigation. If this energy is obtained from neighboring feeders, the system is called interline dynamic voltage restorer (IDVR) [6-8]. The two-line IDVR consists of two back-to-back DVRs connected to different independent distribution feeders in the power system with a common DC bus as shown in Fig. 1. One of the involved feeders is feeding a critical load (critical feeder). If the voltage at both feeders is normal, the inverters are bypassed.

When the critical feeder is subjected to voltage sag, its inverter will operate under voltage control mode and inject suitable voltage to compensate the sag. This voltage compensation consumes power from the DC link, i.e. the voltage of the common DC capacitor will start in decreasing.

To maintain constant DC voltage level during the compensation period, the neighbor feeder's DVR will be operated under power control mode, since it becomes responsible for replenishing the DC link voltage via pumping active power into the DC bus. Due to limitation on the maximum power can be extracted from the neighboring feeder, this paper presents the renewable energy supported IDVR; in the proposed system renewable energy sources are

coupled across the DC link (as a support) to share in supplying the required active power if needed. The DC voltage regulator (PI-controller) generates the required power level to replenish the DC link.

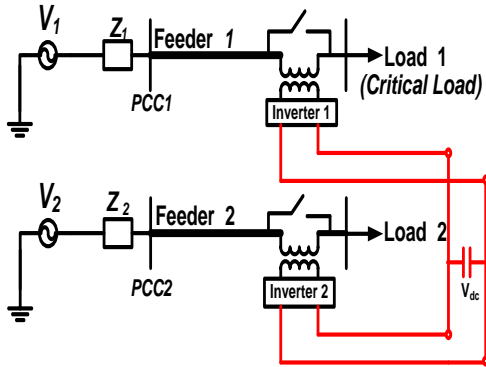

Fig 1: Two-line Interline dynamic voltage restorer (IDVR)

### TWO-LINE IDVR SYSTEM

If feeder1 is feeding a critical load and is subjected to voltage sag. On the other hand, voltage of feeder2 is normal. Inverter1 will be operated under voltage control mode to compensate for the sag and the required active power for restoration will be absorbed from the DC bus. The amount of needed active power is decided by the type of voltage-restoration method [9, 10], namely, in-phase injection, pre-sag supply voltage injection and energy saving injection. This paper uses the in-phase technique. Fig.2 shows the inverter's AC voltage controller when in-phase technique is employed.

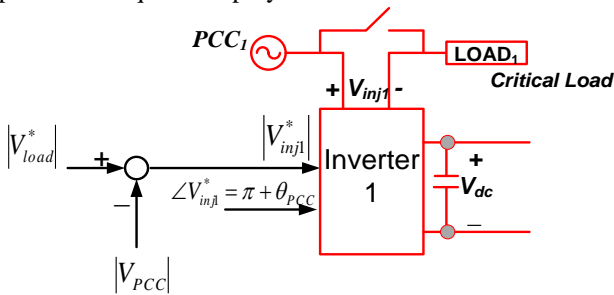

Fig.2 AC voltage controller at feeder1 (in-phase restoration technique)

Inverter2 will be responsible for maintaining constant DC link voltage by restoring the energy absorbed from the link via injecting suitable voltage in series with feeder2.

DC voltage error ( $V_{dc}^* - V_{dc}$ ) is regulated using a proportional-integral controller (PI) which estimates the required active power to be pumped by the neighbor feeder to the link. This power level is fed to power controller to estimate the suitable voltage to be injected. The analytical relations are presented in this section.

Fig. 3 shows pharos diagram of the feeder2 when its inverter is operated under power control mode. The

voltage injection should not perturb the load voltage magnitude. Moreover, the power consumed by this injected voltage represents the required power to be transferred.

From Fig. 3, the length of chord ( $ab$ ) is equal to the injected voltage magnitude. The chord length is given by (1). This length is depending on the value of angle  $\beta$ , which is depending on  $P_{ex}$ , where  $P_{ex}$  represents the pumped power from feeder2 to mitigate sag problem at feeder1.

$$ab = |V_{inj2}| = 2V \sin(\beta/2) \quad (1)$$

From Fig. 3, the per-phase supplied power ( $P_{s2}$ ) and load power ( $P_L$ ) of feeder2 are given by (2) and (3) respectively.

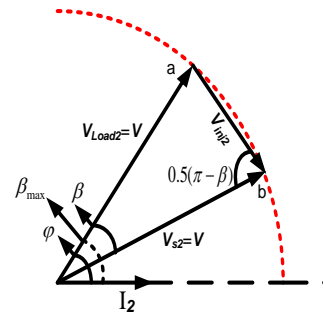

Fig. 3 Phasor diagram of feeder2 during voltage sag at feeder1

$$P_{L2} = |I_2|V \cos \varphi \quad (2)$$

$$P_{s2} = P_{L2} + P_{ex} = V|I_2|\cos(\varphi - \beta) \quad (3)$$

Hence

$$\beta = \varphi - \cos^{-1}\left(\frac{P_{L2} + P_{ex}}{V|I_2|}\right) \quad (4)$$

From phasor diagram in Fig.3, the injected voltage phasor must be set as in (5) to transfer active power without affecting the load voltage magnitude.

$$\overline{V_{inj2}} = 2V \sin(\beta/2) \angle 0.5(-\pi + \beta) \quad (5)$$

The maximum value of  $\beta$  is the load displacement factor angle  $\varphi$ . This corresponds to the maximum allowable power drawn from feeder2 creating unity input displacement factor on feeder2. Thus, for a given load displacement factor, the per-phase maximum available value of  $P_{ex}$  is given by (6).

$$P_{ex_{max}} = V|I_2|(1 - \cos \varphi) \quad (6)$$

Equation (6) shows that the maximum power which can be pumped is depending on the load displacement factor. At a high displacement factor, this power will be limited and may be insufficient, i.e. if the needed power for voltage restoration is larger than the maximum available power; another source will be needed to share in feeding the required power.

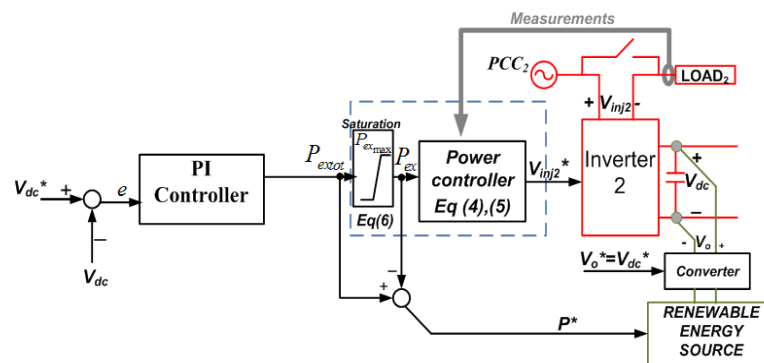

Fig. 4 Power controller of at feeder2 (Renewable Energy Fed IDVR)

Fig. 4 shows the power controller at feeder2 when renewable energy sources are coupled across the DC link. The power management between feeder2 and renewable energy sources can be done by using saturation block after the PI-controller output to trim the power order,  $P_{extot}$ , to the maximum power which can be extracted from feeder2 (as in (6)). The difference between the PI-controller output and saturation block output ( $P_{extot} - P_{ex}$ ) is fed to renewable energy source (as a power reference). It has to be noted that the power electronics converter is used to convert the renewable energy source output voltage to the DC link voltage level.

**SIMULATIONS**

If the neighboring power is not sufficient, another energy source may be used to share in supplying the required active power as shown in Fig. 4 (Renewable Energy Supported IDVR). The parameters of this case are given by Table I.

In this case; Feeder1 is subjected to 20% voltage sag, the required power for voltage restoration using in-phase technique  $P_{extot}$  is 1450 W. Neighbor feeder (feeder2) is feeding 0.9 power factor load, i.e. the maximum power which can be pumped by feeder2,  $P_{exmax}$ , will be 1025W (Eq(6)). It is obvious that the power of the neighbor feeder will not be sufficient to mitigate the sag ( $P_{exmax} < P_{extot}$ ).

Refereed to Fig.4, since the input of the saturation block is greater than its maximum limit, the block will limit the output to the maximum limit (i.e.  $P_{ex} = P_{exmax} = 1025W$ ); so the difference between the required power and the available power of feeder2 ( $P^* = P_{extot} - P_{ex} = 1450W - 1025 W = 425 W$ ) will be fed as a reference to the renewable energy source. From table I data, the maximum power can be extracted from the PV modules is 450W, i.e. PV available power is sufficient to mitigate the sag. It has to be noted that if the photovoltaic available power is not sufficient for voltage restoration, the voltage sag mitigation will fail if the sag duration is long. In this case a model of a two-line IDVR in conjunction with PV modules has been built using Matlab/Simulink. Boost converter is used to boost the

photovoltaic output voltage to the DC link voltage level. The power flow diagrams for this case before and after applying the voltage sag are shown in Fig.5a and Fig.5b respectively.

Fig.5c-5e shows the response of PV variables (power, voltage and current) during the voltage sag. It is obvious that, the PV modules pump 425W (Fig.5c). The variation of PV output voltage and current is shown in Fig. 5d and Fig.5e respectively. The boost converter is used to boost the PV voltage level to the DC bus level at the same power.

TABLE I – SIMULATION DATA

<b>Feeder1</b>	220V per phase
	50Hz
	20% voltage sag for 0.1<t<0.2s
<b>Load1</b>	15.556A
	0.707 pf Lag
<b>Feeder2</b>	220V phase
	50Hz
<b>Load2</b>	15.556 A
	0.9 pf Lag
<b>Renewable Energy Source</b>	5 series connected PV modules are used, each module has 90W maximum power, 17.6V maximum voltage, 5.11A maximum current, 22.3V open circuit voltage and 5.5A short circuit current.

**CONCLUSIONS**

This paper proposes renewable energy supported IDVR for voltage sag mitigation in the distribution grids. The Renewable energy sources are coupled across the system DC link to share in supplying the required active power if the maximum allowable power for injection from the neighboring feeder is not sufficient to mitigate the voltage sag. All analytical relations are presented in this paper. Simulation results supported the proposed concept.

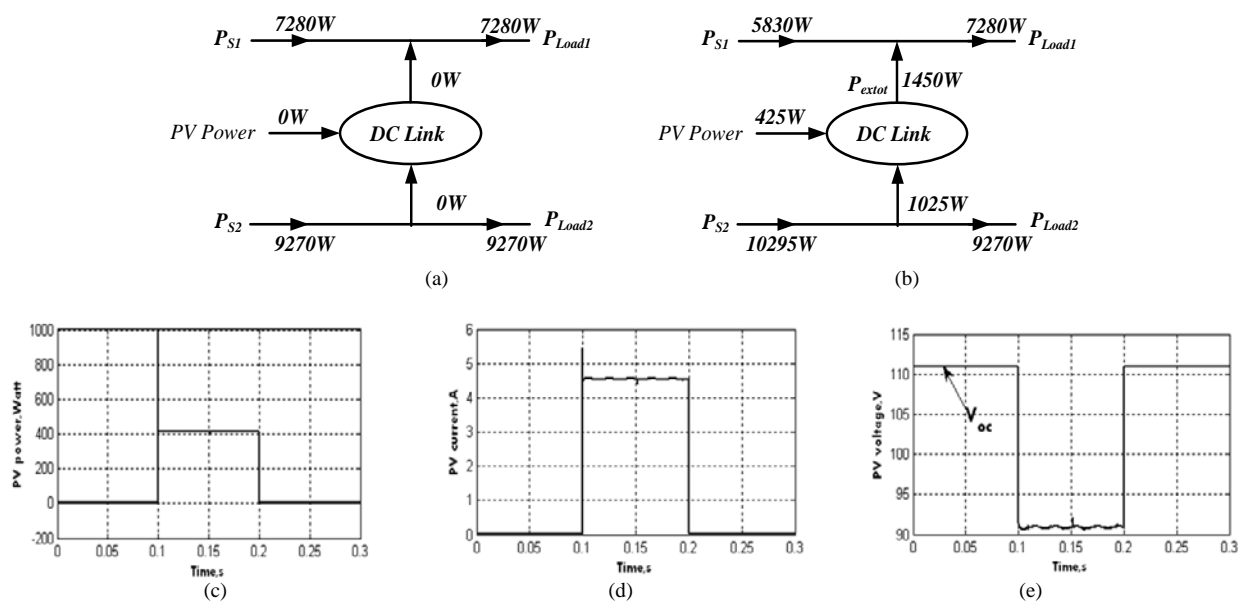

Fig.5 Case2 Simulation Results (a)Power flow diagram of the system during normal operating condition, (b) Power flow diagram during voltage sag, (c), (d) and (e) PV modules power, current and voltage.

## REFERENCES

- [1] Ho, C.N.; et al; 2008 , "Design and Implementation of a Fast Dynamic Control Scheme for Capacitor-Supported Dynamic Voltage Restorers" *Power Electronics, IEEE Trans.* Vol. 23 , No. 1 , pp. 237 – 251.
- [2] Teke, A.; Bayindir, K.; Tumay, M.; 2010, "Fast sag/swell detection method for fuzzy logic controlled dynamic voltage restorer," *Generation, Transmission & Distribution, IET* ,Vol. 4 , No.1, pp.1 – 12.
- [3] Chi-Seng Lam; et al; 2008, "Voltage Swell and Overvoltage Compensation With Unidirectional Power Flow Controlled Dynamic Voltage Restorer" *Power Delivery*, Vol. 23 , No. 4 , pp. 2513 – 2521.
- [4] Meyer, C.; et al, 2008, "Optimized Control Strategy for a Medium-Voltage DVR—Theoretical Investigations and Experimental Results" *IEEE Trans. on Power Electronics*, Vol. 23 , No. 6 ,pp. 2746 – 2754.
- [5] A. Ghosh and G. Ledwich,2002, "Compensation of distribution system voltage using DVR," *Power Del. Trans.*,Vol. 17, No.4, pp. 1030–1036.
- [6] Vilathgamuwa, D.M.; Wijekoon, H.M.and Choi S.S, 2003, "Interline dynamic voltage restorer: a novel and economical approach for multi-line power quality compensation," *Industry Applications Conference. 38th IAS Annual Meeting*, pp. 833 - 840 ,Vol.2.
- [7] Wijekoon, H.M.; Vilathgamuwa, D.M.; Choi, S.S.,2003, " Interline dynamic voltage restorer: an economical way to improve interline power quality," *Generation, Transmission and Distribution*, IEE Proceedings, Vol. 150, Issue 5, pp. 513 – 520.
- [8] D. Mahinda, H. M. Wijekoon, and S. S. Choi, 2006, "A Novel Technique to Compensate Voltage Sags in Multi-line Distribution System-the Interline Dynamic Voltage Restorer," *IEEE Trans. on industrial electronics*, Vol. 53, No. 5, pp. 1603-1611.
- [9] Hongfa Ding, et al, 2002, "A Novel Dynamic Voltage Restorer and its Unbalanced Control Strategy Based on Space Vector PWM," *Electrical Power and Energy Systems*, vol. 24, pp. 693-699.
- [10] Massoud, A; Ahmed, S; Enjeti, P; Wayne Williams, B; 2010, "Evaluation of a Multilevel Cascaded Type Dynamic Voltage Restorer Employing Discontinuous Space Vector Modulation," *Industrial Electronics, IEEE Trans.* ,Vol. 57, No. 7, pp.2398 – 2410.