

RADIATION EXPOSURE FROM ELECTRIC POWER LINES AND METHODS FOR REDUCING THE MAGNETIC FIELD GENERATED BY DISTRIBUTION NETWORK

Ahmad ANANY
N. Delta. Dist. Elec. Co., Egypt
ahmadanany63@yahoo.com

ABSTRACT

The characteristics of current density induced inside human body under 60 HZ extremely low frequency magnetic fields are shown. Calculations have been done by applying one technique of simulating the induced currents in the human body, using a MATLAB program. We created a phantom experiment; human model was composed of organ (homogeneous brain), whose shape was expressed by spheroid. The obtained results can detect the degree of danger due to the induced currents from EMF. We presented the recommended actions and the methods for reducing the magnetic fields generated by overhead power lines. For passive loop method, a reduction algorithm is described and related equations for magnetic fields reduction are explained.

INTRODUCTION

The human body contains free electric charges that move in response to forces exerted by charges on and currents flowing in nearby power lines. The processes that produce these body currents are called electric and magnetic induction. Magnetic fields are directly proportional to the amount of current induced or generated. It cannot be shielded by vegetation, buildings or any ordinary material. For this reason, risks associated with exposure to magnetic fields have been undertaken in most epidemiological studies. To investigate current densities inside human body under 60HZ electromagnetic fields, we applied a simplified method which considers the living organism as a homogeneous cylinder of constant conductivity. Current densities induced in organs are calculated and measured by the use of a phantom experiment. The passive loop is the most cost- effective power frequency magnetic fields reduction method. In particular it can be cost- effectively applied to the restricted area near the transmission lines where people live. The magnetic field produced by transmission lines has to be reduced to an exposure level safe for human health. In this paper, a magnetic field reduction algorithm for the restricted area near transmission lines based on passive loop is described. Further, related equations are explained.

CALCULATION

This method considered the living organism as an electrically homogeneous cylinder, which is electrically isolated from its surroundings by dry air. Spatially

uniform magnetic field H will induce an electric field in the exposed body, according to Faraday's law, the electric field E_i [1]

$$E_i = (\partial B / \partial t) * (r/2) \quad (1)$$

$$E_i = -j\omega B * (r/2) \quad (2)$$

$J = \pi r f \sigma B$, where

J: current density (mA/m²)

σ : the human body conductivity assumed to be 0.1 (S/m)

B: magnetic field density assumed to be 0.1 (mT)

F: 60HZ ELF magnetic fields

r: radial distance from the centre of the cylinder to the point where E_i is evaluated.

Applying this method on a person with head radius=0.1m and body radius=0.3m.

RESULTS AND DISCUSSIONS

The calculated induced current densities at human head were 0.1884 mA/m² and that at the human body was 0.5652 mA/m². The average induced current was 0.3768 mA/m².

PHANTOM EXPERIMENT

To measure the induced currents in human body, the magnetic fields generation apparatus is designed as in Fig. 1 Four groups of coils are positioned to make uniform vertical fields varying from 0.1 to 0.3mT. A schematic view of the measurement system is shown in Fig. 2

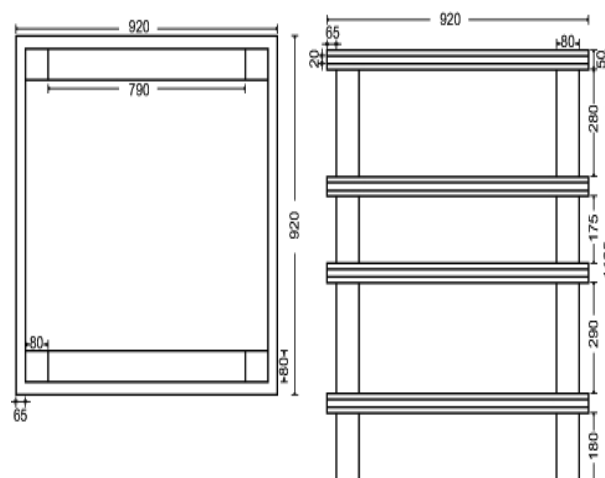

Fig. 1 Apparatus for uniform field generation

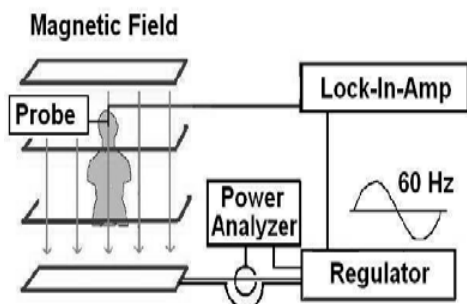

Fig. 2 Schematic of the measurement system

The mode of (brain) organ is made as in Fig. 3

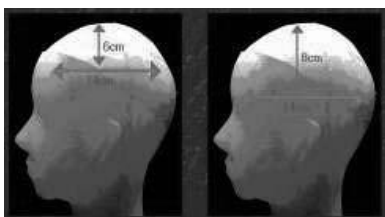

Fig. 3 Mode of brain organ

HOMOGENEOUS BRAIN MODEL

Fig. 4 shows current densities measured in the head having homogeneous conductivity 0.2 (S/m) at $f = 60\text{HZ}$ with different measuring points according to depth (6cm & 8cm) when exposed to 0.1, 0.2 and 0.3mT. The magnitude is higher at 8cm depth than 6cm depth.

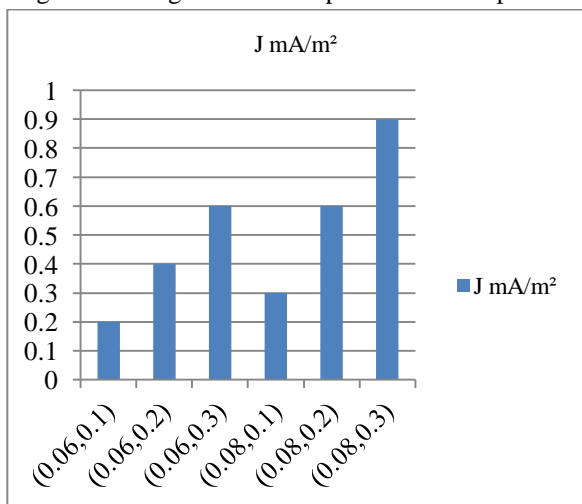

Fig. 4 Current densities measured in homogeneous head model

MAGNETICFIELD REDUCTION (MATERIAL SHIELDING)

Field management can be achieved through use of material shielding. Material shielding of ac magnetic fields uses either conductive material or ferromagnetic material. Connections between sections of shielding material should be securely joined by soldering or welding.

MAGNETIC FIELD REDUCTION (PASSIVE LOOPS)

Passive loops are oriented so that their field will reduce the existing magnetic field. Current is induced in passive loops, however, by the existing field. Passive loops usually consist of single large conductors to minimize impedance. A series capacitor is often placed in the loop to help cancel the loop’s inductive reactance, thus lowering the loop’s overall impedance. Passive loops are self-regulating and require no external power. Passive loops are optimized for peak field-cancellation performance at a specific frequency.

Magnetic field reduction (Passive) Algorithm

Algorithm can be shown in Fig. 5

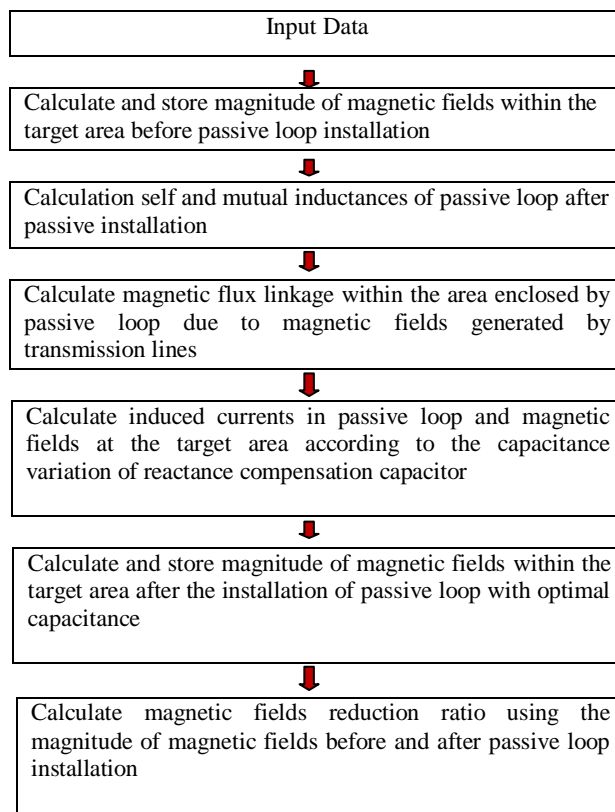

Fig. 5 Magnetic field reduction (Passive) Algorithm

Magnetic Field calculation before passive installation

Magnetic fields within the target area before the installation of passive loop are calculated based on the BIOT SAVART law [2]. Fig [6] shows a transmission line parallel to the x-axis and the line current I (A), flows in this transmission line. Magnetic field intensity at point (x, Y, Z) is calculated using (1)

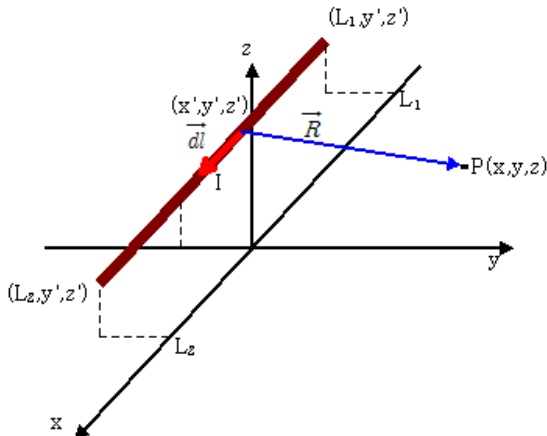

Fig. 6 Magnetic field at point P, in which the line current is parallel to the x-axis

$$\vec{H} = \frac{1}{4\pi} \int_{line} \frac{d\vec{l} \times \vec{R}}{R^3} \quad (1)$$

Where,

$$d\vec{l} = dx \hat{x}$$

$$\vec{R} = (x-x') \hat{x} + (y-y') \hat{y} + (z-z') \hat{z}$$

After the integration of L1 to L2 with variable x, the magnetic field intensity at point P(x, y, z) because of finite line current is expressed as follows:

$$\vec{H} = \frac{I}{4\pi} \frac{(Z-z)\hat{y} - (y-y')\hat{z}}{(y-y')^2 + (z-z')^2} \times \left\{ \frac{x-L_2}{\sqrt{(x-L_2)^2 + (y-y')^2 + (z-z')^2}} - \frac{x-L_1}{\sqrt{(x-L_1)^2 + (y-y')^2 + (z-z')^2}} \right\} \quad (2)$$

Magnetic field intensity at point P (x, y, and z) because of transmission line scan is calculated from the vector summation of the contribution of each transmission line.

Calculation of Self and Mutual Inductances of Passive Loop

The general shape of a passive loop for magnetic field reduction within the restricted area in the vicinity of transmission lines is of the grid type. In this section, self and mutual inductances of passive loop consisting of two grids, Fig (7) are calculated. Given that the passive loop shown Fig parallel to the x-z plane, the magnetic field intensity on the surface of the passive loop because of induced current in conductor 1, 4 of element 1 is expressed as (3).

$$\vec{H} = \frac{i_1}{4\pi} \frac{1}{z-z_1} \times \left\{ \frac{x-x_2}{\sqrt{(x-x_2)^2 + (z-z_1)^2}} - \frac{x-x_1}{\sqrt{(x-x_1)^2 + (z-z_1)^2}} \right\} \quad (3)$$

The magnetic flux linkage with element 1 of the passive loop because of the induced current in conductor 1, 4 of

element 1 can be obtained from (4)

$$\Phi = \int_{z_1}^{z_2} \int_{x_1}^{x_2} B dx dz = \int_{z_1}^{z_2} \int_{x_1}^{x_2} \mu H dx dz \quad (4)$$

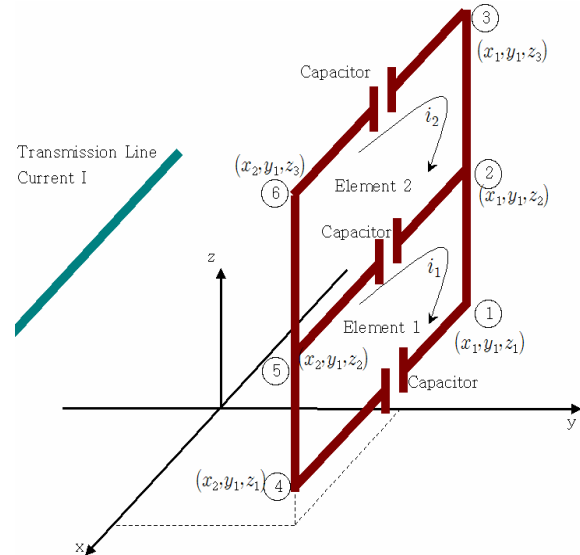

Fig. 7 The passive loop consists of two grids

Calculation of induced electromagnetic in passive loop

According to Faraday's law of induction, induced electromagnetic, V, in each element of the passive loop due to the change in the magnetic flux generated by transmission lines is given as (5).

$$V = - \frac{d\Phi}{dt} \quad (5)$$

Considering that the passive loop is parallel to x-z plane, only the y-directional component of the magnetic field intensity is effective for induced electromagnetic. This happens because the magnetic flux linkage is obtained by the integration of the dot product of the magnetic flux density and the vector representing the element of the area over the surface of each element of the passive loop. This is given as follows:

$$\Phi = \int_S \vec{B} \cdot d\vec{a} \quad (6)$$

The y-directional component of the magnetic field intensity because of the current of transmission lines is given as (7).

$$\vec{H} = \frac{I}{4\pi} \frac{(Z-z)\hat{y}}{(y-y')^2 + (z-z')^2} \times \left\{ \frac{x-L_2}{\sqrt{(x-L_2)^2 + (y-y')^2 + (z-z')^2}} - \frac{x-L_1}{\sqrt{(x-L_1)^2 + (y-y')^2 + (z-z')^2}} \right\} \quad (7)$$

Magnetic flux linkage with element 1 of the passive loop because of the current of transmission lines can be calculated by (8).

$$\Phi = \int_{z_1}^{z_2} \int_{x_1}^{x_2} \mu H_y dx dz \tag{8}$$

The y-directional component of the magnetic field intensity at any point within the surface enclosed by element 1 of the passive loop due to the current of transmission lines can be reduced to (9).

$$\vec{H}_y = \frac{I}{2\pi} \frac{(z-z')y'}{(y-y')^2+(z-z')^2} \tag{9}$$

By substituting (9) for H_y in (8) and by integrating (8) analytically, the magnetic flux linkage results in (10).

$$\Phi = \frac{\mu I}{4\pi} (x_2-x_1) \ln \left\{ \frac{(y-y')^2+(z_2-z')^2}{(y-y')^2+(z_1-z')^2} \right\} \tag{10}$$

Calculation of Induced Currents in Passive Loop

Induced currents in the passive loop can be obtained by (11). The elements of the impedance matrix are shown in the following equation:

$$\begin{bmatrix} V1 \\ V2 \end{bmatrix} = \begin{bmatrix} Z11 & Z12 \\ Z21 & Z22 \end{bmatrix} \begin{bmatrix} i1 \\ i2 \end{bmatrix} \tag{11}$$

The impedance matrix consists of self and mutual inductances calculated before.

Magnetic field calculation after passive loop installation

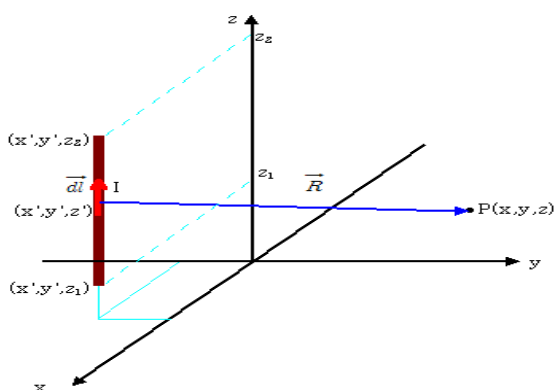

Fig. 8 Magnetic field generated by current flowing in the vertical conductor of a passive loop

The magnetic field at any point within the target area after passive loop installation is generated because of both the currents of transmission lines and the induced currents in the passive loop.

The magnetic field generated by the transmission lines and the conductors of the passive loop parallel to the x-axis can be obtained by (2). The magnetic field generated by the conductors of the passive loop parallel to the z-axis, as shown in Fig. 8 can be obtained by (12).

$$\vec{H} = \frac{I}{4\pi} \frac{(x-x')y'-(y-y')x'}{(y-y')^2+(z-z')^2} \times \left\{ \frac{z-z_2}{\sqrt{(x-x')^2+(y-y')^2+(z-z_2)^2}} - \frac{z-z_1}{\sqrt{(x-x')^2+(y-y')^2+(z-z_1)^2}} \right\} \tag{12}$$

Magnetic Field Reduction Factor

The magnetic field reduction factor is defined as follows:

$$FRE \left[1 - \frac{H_A}{H_B} \right] \times 100 [\%] \tag{13}$$

Where H_A and H_B are the magnetic field intensities after and before passive loop installation, respectively.

CONCLUSION

It is noticed that the maximum calculated induced current densities was 0.5652 mA/m², which is so small when compared to the ICNIPR standard (10mA/m²) that may produce any significant biological effects. But it has to be noticed that these induced current densities from short-term exposure (few hours) that it may cause minor transient effects on health. Long term exposure may cause dangerous effects [3].

A power frequency magnetic field reduction method using a passive loop is presented. This method can be used to predict magnetic field reduction within the restricted area near transmission lines, if electrical and geometrical parameters of transmission lines and passive loop are given. A reduction algorithm is described and related equations for magnetic field reduction are explained. In particular, it is the main advantage of the proposed algorithm compared with other passive loop methods, in which the optimal capacitance of the compensation capacitor can be calculated. This gives the maximum field reduction factor within the target area.

REFERENCES

[1] Charles Polk, "Biological effects of low-level-low-Frequency Electric and Magnetic Fields", *IEEE Trans. on Education*, Vol. 34, No. 3, August 1991, PP 243–249.

[2] P. Lorrain, D.R. Corson, "Electromagnetic Fields and Waves", 1970.

[3] [http:// www.inchem.org](http://www.inchem.org).