

NEW MEDIUM VOLTAGE CIRCUIT-BREAKER SWITCHGEAR WITH ADVANCED FUNCTIONALITY

SERGIO SEBASTIÁN MARTÍN
Ormazabal – Spain
ssm@ormazabal.com

JUAN JOSE CARMONA CATALÁN
Ormazabal – Spain
jjc@ormazabal.com

ABSTRACT

A standard well-known circuit-breaker switchgear combines two main components with different responsibilities: one circuit-breaker to make and break the current, and one disconnecter to reach isolating distance when the circuit-breaker has opened the circuit. The operating sequence of these two components is allowed or avoided by interlocks.

Currently the functionality of the network is changing. The irruption of smart grid concepts includes new applications: distributed generation, new quality standard requirements, etc. All these new requirements will be fulfilled thanks to a new generation of smart components able to manage a lot of information and to operate, even remotely, the network in different situations according to local and external information. But, what about the switchgear? Is it currently able to achieve the expected functionality? Will a new generation of devices be necessary?

A circuit-breaker function equipped with an improved load break switch instead of a disconnecter increases the features for a new generation of smart grid applications.

STANDARD CIRCUIT-BREAKER SWITCHGEAR

The standard circuit-breaker switchgear is a well-known combination of components, taking advantage the suitable technology of each component to fulfil a whole requirement. These components easily recognized are:

Circuit-breaker

It has the duty to break all kind of currents, from low currents (as cable charging current or magnetizing current in transformers) to short-circuit current, including nominal current (mainly active load currents).

It has also the duty to make all kind of current, up to short-circuit current. This device has to fulfil all the requirements of international standard IEC 62271-100 depending on the application.

Currently the most usual technology of this circuit-breaker in Medium Voltage is vacuum, due to several advantages such as high electrical endurance up to very high currents and mechanical endurance.

The vacuum technology has low arc voltage and rapid recovery that allows this high electrical endurance, even for fault currents with severe transient recovery voltage, and ability to break high frequency currents.

Besides, the contacts in vacuum have neither oxidation nor

deterioration, and it can break in stationary state.

These features are the reason to use vacuum technology as the most suitable technology for different applications in Medium Voltage, because it is capable to make and break different kind of currents checked by testing; short-line fault, out of phase, electrical endurance, single phase and double earth fault tests, line-charging and cable-charging current breaking tests, single and back-to-back capacitor bank switching tests, etc.

On the other hand, there are some effects that can appear in very unusual occasions that are statistically low probable and can be solved or minimized with the arc control, new contact materials and new contact designs, but that we have to take into account and which are described below.

Chop current

The chop current is a well-known phenomenon that appears sometimes in circuit-breakers when small currents of some kind (mainly active currents, inductive currents ...) are broken. Due to different factors, the current does not wait to zero crossing to be broken, and the peak of TRV is higher with risk of reignition.

This effect could appear with low currents less than 25 A. Even, with advanced designs of circuit-breakers contacts, it could appear only with currents below 5A. Besides, this effect could be emphasized when inductive currents are broken, because the TRV peak is even higher, so there is more risk of reignitions.

NSDD, restrikes and voltage escalation in capacitive switching

When the circuit-breaker opens capacitive circuits, on unusual occasions during a test, restrikes and Non-Sustained Disruptive Discharge (NSDD) could appears.

If a restrike appears, due to the power frequency current, the capacitive polarity of the circuit changes, so the voltage on load side escalates from 1 pu to 2,5 pu. Due to this effect, the voltage withstood by the open gap of the circuit-breaker has to be greater, so the probability to appear another restrike is higher. If a second restrike happens, the load side escalates from 2,5 to 4,5 p.u., and this could be repeated several times.

This behaviour is more probable in vacuum circuit-breakers, although it is not sure that could cause problems in a real network.

Voltage escalation by multiple reignitions in inductive switching

In inductive circuits, such as transformers and motors, the

breaker has to interrupt a very small current, but the inductance is very high. Due to this small current, the circuit-breaker breaks the current just before zero crossing with minimum gap distance, so it is probable that the current were re-established. Due to this kind of circuits, the current re-established is a high-frequency current coupled to power frequency current. The current will be broken probably in the first zero crossing of this high-frequency current another time. If the gap distance is not enough yet, another reignition will happen. This could be repeated several times and would cause a voltage escalation by multiple reignition.

This is a relatively infrequent phenomenon.

Disconnecter & Earthing switch

It has the duty to assure isolating distance for service or maintenance practices, when the circuit-breaker has opened the circuit previously. Besides, in order to assure a secure operation, for example under fault situation, this device should be able to withstand dynamic and thermal effects of a short-circuit when is in closed position.

The most usual technology for this disconnector is SF6 due to the great reliability of this medium for dielectric requirements.

On the other hand, it is typical to have an earthing switch to allow a safe earthing connection of the accessed circuit (i.e. feeder). This device should also be able to withstand dynamic and thermal effects of a short-circuit when is in closed position.

The international standard IEC 62271-102 defines the requirement for these devices and the relevant type tests that should be fulfilled.

Interlocks

The interlocks have the duty to allow or avoid the operation of circuit-breaker, disconnector and earthing switch. The most common operating sequence for a typical disposition (next figure) is described below.

Main circuit closing:

- To close disconnector (because it could not have making capability) and then to close circuit-breaker.

Opening:

- To open circuit-breaker first (because it is the unique device with breaking capacity) and then to open the disconnector or the earthing-switch.

Earthing closing:

- To close earthing switch first (because it could not have making capability) and then to close circuit-breaker.

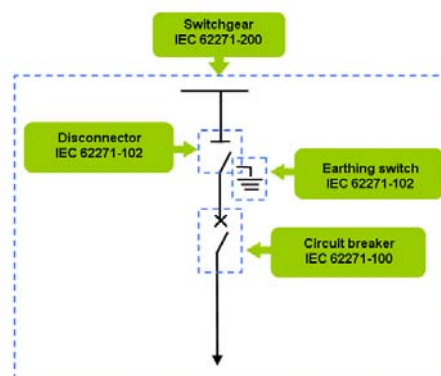

NEW CIRCUIT-BREAKER SWITCHGEAR WITH ADVANCED FUNCTIONALITY

The implementation of a load break switch in SF6 medium, even a three position load break switch instead of a classical disconnector allows to increase features and improvements as the simplification of mechanical interlockings, to extend the electrical and mechanical endurance and to have an smart and advanced circuit-breaker panel that decides which is the most appropriate device (load break switch or circuit-breaker) to break or make the current depending on the conditions of the circuit at that very moment.

In this section these features are shown and explained in order to realize the circuit-breaker function with extended functionality.

Features and Performance

Chop current is avoided

In order to avoid the chop current effect, the breaking duty of currents up to nominal current (e.g. 630A), is transferred to load break switch-disconnector instead of circuit-breaker, because the breaking of these currents are more suitable for load break switches in SF6-medium than vacuum circuit-breakers.

So, with this advanced functionality, the TRV peak reached in this breaking duties is lower, so the overvoltages are lower and the insulation of the network is less stressed, specially dry transformer that are very sensible to this kind of overvoltages.

NSDD, restrikes and voltage escalation are avoided in capacitive switching

Both disturbances (Restrikes and NSDDs) are avoidable with the advanced functionality explained in this paper, because the breaking duty of a capacitive circuit is transferred to the load break switch-disconnector. This load break switch will open the capacitive circuit in SF6-medium, so restrikes and NSDD's are less probable.

It has been possible to transfer the breaking duty to the load break switch because, in this kind of circuits, the TRV is slow and the current is small, so, from this point of view, an SF6 load break switch is a more suitable breaker.

Typical capacitive circuits where this technology is used are

cables and overhead lines, and they are tested according to the standards as cable-charging current and line-charging current.

Inductive Voltage escalation by multiple reignition is avoided

This happens as a result of chop current effect and reignition due to, in the breaking current instant, the gap distance reached but the circuit-breaker contacts is not enough to withstand the voltage.

In spite of being a relatively infrequent phenomenon, this effect is avoidable if the inductive circuit is opened by the load break switch-disconnector instead of circuit-breaker, because the breaking time of SF6 switch is longer, so the gap distance reached by the contacts is bigger without possibility of reignition.

Electrical Endurance & Mechanical Endurance

According to switch standard IEC 60265-1 (now IEC 62271-103), a general purpose switch with electrical endurance class E3 has the capability of performing a high electrical endurance of load breaking currents and short-circuit makings. In our case, the use of a load break switch-disconnector located upstream the circuit-breaker instead of a disconnector is able to make and break the nominal current (e.g. 630 A) 100 times and to make the short-circuit current (e.g. 20kA) 5 times withstanding 200 ms short-circuit each time.

Regarding mechanical endurance, a general purpose switch with extended mechanical endurance class M2 for frequent operation will have 5000 operations.

On the other hand, according to circuit-breaker standard IEC 62271-100, the rating operating sequences for circuit-breakers are O – t – CO – t' – CO or CO – t – CO.

Both sequences have 2 short-circuit makings with immediate (e.g. 80 ms) breaking for circuit-breaker without auto-reclosing and 4 short-circuit makings for circuit-breakers with auto-reclosing (class E2).

Besides, circuit-breakers manufacturers used to assure how many times the breaker is able to break the nominal current (e.g. 630 A), and they used to be the same number of operations as mechanical endurance (2000 or 10000 times). Regarding mechanical endurance, there are 2 alternatives; a circuit-breaker with normal mechanical endurance class M1 will have 2000 operations (enough assumed for Circuit-breakers without auto-reclosing to protect a distribution transformer or underground lines) and a circuit-breaker for frequent operation with extended mechanical endurance class M2 will have 10000 operations (used normally to protect distribution lines)

So, due to this advanced functionality, as a load break switch-disconnector has short-circuit making capability in the disconnector function, the circuit-breaker and switch-disconnector can add and combine its functions as it's shown in Table 1.

		FEATURES		
		N° short-circuit makings	N° nominal current operations (*)	Mechanical Endurance (N° operations)
Circuit Breaker without auto-reclosing	Normal functionality (Combined with disconnector)	2	2000	2000
	Advanced functionality (Combined with switch)	2+5	2000+100	2000+5000
	Improvement achieved	360%	5%	360%
Circuit Breaker with auto-reclosing	Normal functionality (Combined with disconnector)	4	10000	10000
	Advanced functionality (Combined with switch)	4+5	10000 + 100	10000 + 5000
	Improvement achieved	225%	1%	150%

Table1. Improvement achieved with advanced functionality.

(*) There is no significant increase in number of nominal current operation, but there is an improvement in breaking quality, due to different phenomenoms explained before are avoided.

Testing

Validation of these new features of disconnector associated to a circuit-breaker, converted now to a load break switch-disconnector, were achieved through a specific testing procedure based on IEC 62271-200, IEC 60265-1 (IEC 62271-103), IEC 62271-102 and IEC 62271-100.

Mechanical operation test of Interlocks

The switch-disconnector will be able to open and close with the circuit-breaker closed with the objective to use the switch-disconnector to make short-circuit currents and to open nominal currents, cable-charging current, unloaded or loaded transformer, etc.

So, the new possibility to operate the switch-disconnector with the circuit-breaker closed has been tested according to IEC 62271-200 attempting 50 times to operate the switching devices in the different alternatives, fulfilling all the requirements.

Making and Breaking & Short-circuit making test of Switch-Disconnector

The switch-disconnector has been tested according to IEC 62271-103, achieving 100 making and breaking tests at nominal current of 630 A (Class E3, maximum category). Also, it has been tested according to IEC 62271-103 and 62271-102, achieving 5 short-circuit makings at 20kA in service position and 5 short-circuit makings at 20kA in earthing position in the same test object (Class E3, maximum category), according to STL Guide.

Mechanical Endurance of Switch-Disconnector

The switch-disconnector has been tested according to IEC 62271-103, achieving 5000 operations as a switch suitable for special service applications and for frequent operation having an extended mechanical endurance, class M2 (maximum category). Even, this test was carried out with a motorized driving mechanism, so it will be possible to motorize the switch-disconnector.

Cable-charging current test of Switch-Disconnector

The switch-disconnector has been tested according to Test

Duty CC2 and Test Duty CC1 (Cable-charging current switching tests) as a switch with low probability of restrike during capacitive current breaking (class C2, maximum category).

The currents to be broken in these Test Duties are different from Cable-charging current according to IEC 62271-100 (Circuit-breaker duties), but, in any case, the switch-disconnector has been tested with higher values, as it is showed in Table 2.

Rated Voltage	Cable-charging current Test		
	IEC 6227-100	IEC 60265-1 (IEC 62271-103)	Tested by Ormazabal
24kV	31,5 A	16 A	50 A
36kV	50 A	20 A	50 A

Table1 2. Cable-charging current test comparative between IEC 60265-1 and IEC 62271-100.

Benefits

According to tests, the advanced functionality of circuit-breaker switchgear has 2 breakers in series: a circuit-breaker capable to make and break short-circuits current, and a load break switch-disconnector capable to make short-circuit current and break nominal, capacitive and inductive currents.

On the other hand, it is possible to measure the current and/or voltage to have the necessary information to decide which breaker has the breaking duty depending on the current.

Besides, both circuit-breaker and load break switch are motorized, so if all characteristics are combined, a new smart circuit-breaker switchgear is available.

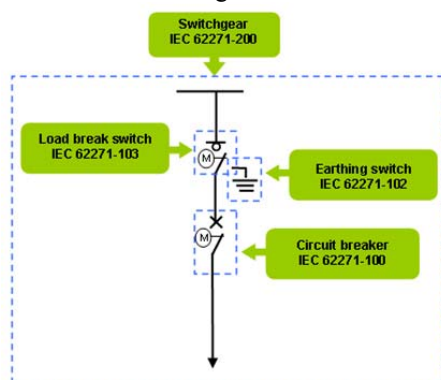

SMART GRID APPLICATIONS

French & ERDF regulation for wind farm operation

French regulation for wind farm operation (>5MW) defines that installations directly connected to MV network shall be able to manage voltage dip line, in order to be still connected more than 150ms. Then, avoiding to islanding function, the wind mills will be disconnected automatically. When the voltage will be recovered in distribution network, each wind mill will be reconnected sequentially, according

to ERDF regulation.

The ORMAZABAL proposal for these applications consists in these new smart circuit-breaker switchgears with advanced functionality equipped with a voltage measurement that detects voltage dips and gives the signal to open the motorized load break switch. If there is a fault, the circuit-breaker will have the breaking duty. So, with this solution, there is an improvement of breaking quality for low currents and increase of mechanical and electrical endurance.

MV network automation applications

To achieve a high quality service in agreement to national energy market regulations, some Utilities have addressed their efforts to implement automatic fault detection system in the MV network in order to minimize supply interruptions consequences, as a result of reducing the part of network affected, isolating the fault.

The most common practise has been to substitute the feeder position switchgear equipped with a load break switch, by a traditional circuit-breaker with disconnector, that allows to reduce the switching time.

The ORMAZABAL proposal for these applications consists in a new smart circuit-breaker switchgears equipped with voltage/current control system that decides which breaker has the breaking duty. In this case, the load break switch would be equipped with a motorized stored energy driving mechanism to reduce the switching time when this breaker opens low currents or no load circuits, and in case of fault, the circuit breaker will have the breaking duty, obtaining the same improvement as before application.

CONCLUSIONS

The irruption of smart grids applications opens a research field for solving new network necessities not only related to control and protection devices, also to switchgears. So, the traditional conception for a circuit-breaker panel could be changed thanks to introduction of a coordinated load break switch-disconnector instead of a disconnector.

Due to the capability of the load break switch to make short-circuit current and break nominal, capacitive and inductive currents, the circuit-breaker switchgear increases the electrical and mechanical endurance and improves the breaking quality avoiding restrikes, reignitions and chop current effects due to the breaking characteristic of SF6 full load break switch, that allows to increase the life of vacuum circuit-breaker, the life of circuit-breaker switchgear and, even the life of the power transformer protected.