

TRANSIENT EARTH FAULT DETECTION ON COMPENSATED EARTHED SYSTEM

Hengxu Ha
ALSTOM Grid Limited, UK
hengxu.ha@alstom.com

Sankara Subramanian
ALSTOM Grid Limited, UK
sankara.subramanian@alstom.com

ABSTRACT

A new technique to detect the fault direction of single-phase-to-earth fault for Petersen's Coil compensated earthed power system is presented in this paper. The proposed technique can make a precise decision on detecting the single-phase-to-earth fault, not requiring higher frequency sampling rates, higher accuracy measurements. It can be implemented in traditional feeder relay with low sampling rate. Presently, the technique has been implemented in an already commercial available relay from author's company.

INTRODUCTION

It is well-known that neutral un-earthed system can reach higher reliability of power supply than the system with neutral directly grounded for single-phase-to-earth fault on the system. In order to extinguish the fault arcs an inductive coil, Petersen's coil is designated on the neutral to compensate the capacitive current.

For neutral un-earthed system, the fault direction can be determined by the zero-sequence steady state reactive power directional relay. As to the neutral compensated systems, it is difficult to determine the fault direction using such technique. The fault current is the mixture of the both inductive and capacitive currents. The inductive current may compensate to capacitive current to be zero, or even over compensate to be inductive, so that there is no characteristic discrimination between forward and reverse ground fault. However the active part of the current (both in transient and steady state) never be compensated. The measured active power or the conductivity, which are respectively called "Wattmeter" and "Conductivity relay", can be employed to determine the fault direction^[1-3]. However, the active current or the conductivity is too small to be measured, unless special CTs with higher accuracy are employed.

It could be a good idea that transient components are employed for fault direction determination. The first-half-wave method, which is actually based on the travelling wave theories, is implemented for fault direction detection in feeder relays^[4]. The transient high frequency components in frequency of 1500~3000Hz are captured for direction detection. It is obviously seen that the higher frequency sampling technique, a special hardware with high frequency sampling function, is required for the technique.

The instantaneous reactive power has been employed for fault direction detection in the feeder relay by Alstom. The Hilbert transform is used to obtain the instantaneous transient reactive power. However, this technique does not match the neutral compensated system.

A new technique for detecting single-phase-to-earth fault direction, which can be implemented in common feeder relay with common frequency sampling rates that requires neither special hardware nor more accurate measurements, for neutral compensated power system, is proposed in this paper. This technique has already been implemented into the P14X feeder relays. Tests by the Comtrades associated to Russia distribution system show that the technique can give the right decision of fault direction.

BACKGROUND

The operation mode of neutral can be classified into two categories: neutral directly earthed (or solid earthed) and neutral indirectly earthed.

Neutral un-earthed system

Compared with neutral directly earthed system, there is very small fault current when a single-phase-to-earth fault occurs on the neutral un-earthed system, for there is only closed circuit mainly via equivalent phase-to-earth capacitances of the system. Furthermore, the phase-to-phase voltages still remain symmetrically operating, so that the single-phase-to-earth fault on neutral un-earthed system gives the less affection on the load than the fault on neutral directly grounded system.

Neutral compensated systems

The single-phase-to-earth faults are mostly arc faults, once the extinguished arc re-burns, it will cause a significant transient over-voltage (generally could reach 2~3 times of rating voltage) on the neutral un-earthed system. In order to limit the over-voltage and at most possibly avoiding the re-burning of extinguished arc, the Petersen coil is connected between the neutral and earth. The compensation degree K_c is defined as the following formula:

$$K_c = \frac{1}{\omega_0^2 3L_p C_\Sigma} \quad (1)$$

where L_p is the inductance of Petersen's Coil, C_Σ is the total equivalent capacitance of the whole system. ω_0 is the fundamental frequency in rad. K_c is the compensation level, for resonant compensation, $K_c=1$; for under-compensation $K_c<1$; for over-compensation, $K_c>1$.

Problems to be solved

The conventional directional relay based on the fundamental frequency component can not give the correct decision for Petersen's Coil compensated system. This can be explained from figure 1. In Petersen's coil compensated system, the fault current can be decomposed to two parts: one is

capacitive current which flows via the phase-to-earth capacitance of healthy phases and healthy lines back, the other one is inductive current which flows through the Petersen's coil.

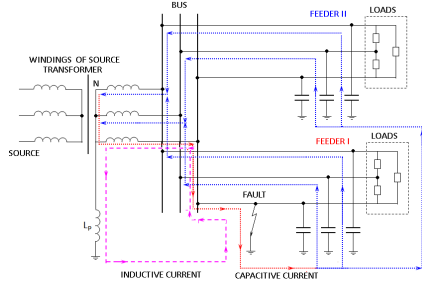

Fig. 1 Fault current as single-phase-to-earth fault occurring

The inductive current might change the direction of the current on faulty phase which direction depends on whether the inductive current is larger than the capacitive current or not, or whether the compensation level K_c is larger than 1. If so, there is no character difference between the faulty line and healthy line, that is, the fault direction can not be correctly detected by the conventional directional relay.

BASIC PRINCIPLE

Although there is no characteristic difference in the fundamental frequency component between the forward and reverse directional fault in steady state, it is not the case in the transient stage.

Equivalent circuit for fault analysis

According to the unbalanced fault analysis theories, when a single-phase-to-earth fault occurs on the system, the equivalent circuit of a typical Petersen's Coil compensated system with two feeders on the bus is shown in figure 2. One can see that the equivalent impedances of transformer are significantly less than that of other impedances, so that the positive and negative network can be neglected.

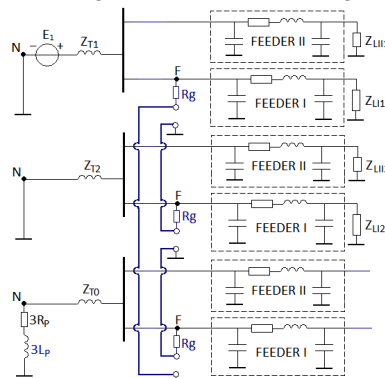

Fig. 2 Equivalent circuit of Neutral Petersen's Coil compensated system as single-phase-to-earth fault happens E_1 is the voltage of the source transformer; Z_{T1} , Z_{T2} and Z_{T0} are respectively the positive-sequence, negative-sequence and zero-sequence equivalent impedance of the transformer; Z_{L11} , Z_{L12} are

respectively the positive-sequence and negative-sequence load impedance of feeder I; Z_{L11} and Z_{L12} are those of feeder II; R_s is the fault resistance; R_p and L_p are respectively the equivalent resistance and inductance of Petersen's Coil; N is the neutral of the three phase system.

The model of feeder

Consider a feeder with d km length and the parameters per length (per km) are respectively R , L and C . The equivalent admittance of the feeder can be written as:

$$Y(\omega) = j\omega Cd / 2 + \frac{1}{Rd + j\omega Ld + 1/(j\omega Cd / 2)} \quad (2)$$

The phase-frequency character of the admittance for a feeder is shown in figure 3. One can see that the phase angle of feeder's admittance is 90 degree in the frequency region below f_1 .

$$f_1 = \frac{1}{2\pi} \sqrt{2(c/d)^2 - (R/2L)^2} \approx \frac{\sqrt{2}c}{2\pi d} \quad (3)$$

where c is travelling velocity of the electro-magnetic wave, d is line length.

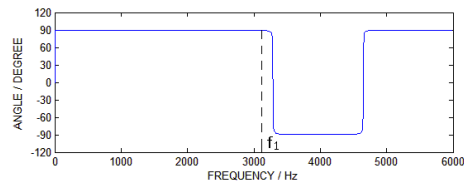

Fig.3 the phase-frequency character of admittance of feeder

Characteristic discrimination

If we focus on the frequency region below f_1 , the feeder can be finally equivalent to be a capacitance shunting with a resistance. So that, the simplest model of the system can be shown as the following figure 4.

For a reverse directional fault, the relationship between the residual current and voltage can be written as:

$$I_H = (G_H + j\omega C_H)V_N \quad (4)$$

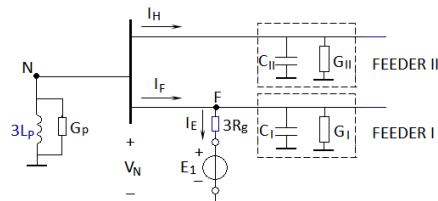

Fig.4 the simplest model (the frequency is below f_1)

For a forward directional fault, that is, the relay on feeder I, such relationship is presented as:

$$I_F = \left\{ -[G_p + (G_\Sigma - G_I)] + j \left[\frac{1}{3\omega L_p} - \omega(C_\Sigma - C_I) \right] \right\} V_N \quad (5)$$

$$= \left\{ -[G_p + (G_\Sigma - G_I)] + j\omega C_\Sigma \left[\left(\frac{\omega_0}{\omega} \right)^2 K_C - \frac{C_\Sigma - C_I}{C_\Sigma} \right] \right\} V_N$$

where G_Σ and C_Σ are the sums of respectively conductance and capacitance of all feeders, K_C is compensation level. Compare the equations (4) with (5), we can conclude:

The reactive part of current for reverse fault is positive, however it is positive or negative for forward fault depends on the frequency of current. If the frequency satisfies:

$$\omega_2 > \sqrt{\frac{K_c}{(C_\Sigma - C_l)/C_\Sigma}} \omega_0 \quad (6)$$

then, the reactive part of current for forward fault is negative. The phase-frequency of equivalent admittance of faulty line is shown in figure 5.

Compare figure 3 with figure 5, one can find that in the frequency region [f2, f1], there is significant character discrimination between the forward and reverse direction faults. That is, in such frequency domain, the equivalent reactive current (or admittance) is capacitive for the reverse fault, however inductive for forward fault.

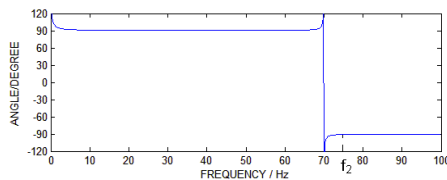

Fig.5 The phase-frequency character of equivalent admittance of faulty feeder (resonant compensation)

PROTECTION SCHEME

The protective scheme is shown in the following.

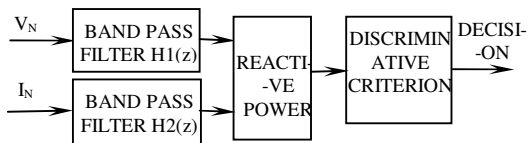

Fig.6 Protective Scheme

The measured residual voltage and current is firstly processed respectively by band pass filter H1 and H2, which eliminate the fundamental frequency signal and amplify the signal in the special frequency band. Subsequently, the reactive power in per-unit value is obtained by passing through the sign filter. And then, the relay will make a decision that the fault is in forward direction or reverse direction.

Band-pass filters for voltage and current

The special frequency which is extracted is selected to the range with the frequency centre of 220Hz. The reason why such frequency selected is that this frequency can avoid the 4 and 5 order harmonics which are rich in the system. The designed digital band-pass filter is shown below.

$$\begin{cases} H_1(z) = \frac{(1-z)(1-z_0z^{-1})(1-\bar{z}_0z^{-1})}{(1-z_1z^{-1})(1-\bar{z}_1z^{-1})} \\ H_2(z) = \frac{(1+z)(1-z_0z^{-1})(1-\bar{z}_0z^{-1})}{(1-z_1z^{-1})(1-\bar{z}_1z^{-1})} \end{cases} \quad (8)$$

where, $z_0 = \exp(-\omega_0 T_s)$ is the zero point for fundamental frequency components, $z_1 = \exp(-\omega_1 T_s)$ is the pole point for 220Hz components which is required for amplifying, T_s is the sampling period. The difference between the two filters

is that filter H_2 is 90 degrees lag to H_1 .

Normalized reactive power

We can obtain the reactive power by directly multiplying the voltage and current after passed through the band pass filters H1 and H2. However, the value range will be very large, so that it is difficult to set the threshold of the reactive power. In order to overcome this problem, the voltage and current after the band-pass filter pass the sign filter first.

$$y = \begin{cases} 1 & x \geq X_{set} \\ 0 & -X_{set} < x < X_{set} \\ -1 & x \leq -X_{set} \end{cases} \quad (9)$$

Subsequently, the normalized reactive power can be obtained by following formula.

$$Q_{TRAN}(k) = \frac{1}{N} \sum_{n=1}^N \hat{u}(k-n+1) \hat{i}(n) \quad (10)$$

where Q_{TRAN} is the normalized reactive power, \hat{u} and \hat{i} are respectively output voltage and current after passing through the band-pass and sign filters. After such processes, the value of reactive power is limited into [-1,1].

Discriminative Criterion

In such frequency band:

(1) Residual voltage LEADS residual current for 90 degrees for a forward fault, so that the normalized reactive power should be negative.

(2) However, voltage LAGS current for 90 degrees for a reverse fault, so that the normalized reactive power should be positive. Therefore the discriminative criterion is shown in the follows:

$$Q_{TRAN} < -0.1 \quad \text{Forward fault} \quad (11a)$$

$$Q_{TRAN} > 0.1 \quad \text{Reverse fault} \quad (11b)$$

$$\text{Otherwise} \quad \text{No decision} \quad (11c)$$

VALIDATION

The technique is implemented into P14x relay by ALSTOM Grid Limited. The tests associated to a set of COMTRADES from the distributed system shown in figure 6.

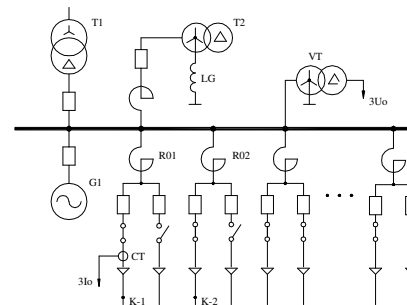

Fig.6 associated distribution system

The parameters of the system is presented below

- (1) 10 kV with 15 outgoing cables;
- (2) Peterson's coil is included in the neutral of the auxiliary transformer;
- (3) Reactor type RBA-10-600-6.
- (4) Capacitive current single-phase ground fault in the

network (without compensation) is 118A. (5) Each feeder has a capacitive current single-phase circuit 7.8A. The total network load of 10 kV is 35 MW at $\cos \phi = 0,8$. Two percent of network capacity is the load included a three-phase rectifier.

Typical forward and reverse fault

Case 1: An internal arc fault occurs on the resonant compensated system, the waveforms during the procedure can be seen in figure 7. One can easily see that the output voltage and current of the filter are in opposite direction after passing through the band-pass filters. After the sign filter, the normalized reactive power is negative.

Case 2: An external arc fault on resonant compensated system, the waveforms are shown in figure 8. One can see that the voltage and current after passing through the band-pass filter are in same direction, the normalized reactive power is positive.

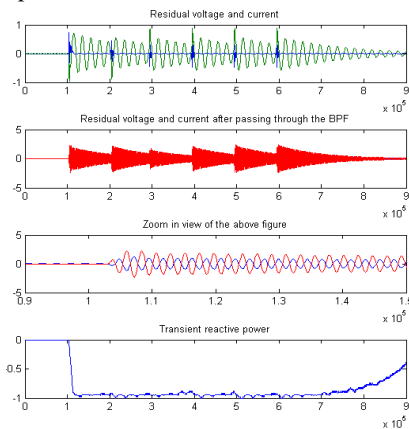

Fig.7 the waveforms during the processing for forward fault on resonant compensated system.

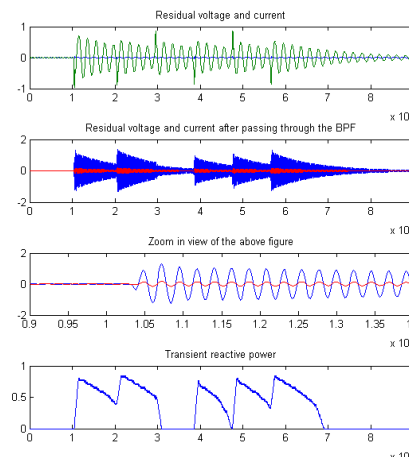

Fig.8 the waveforms during the processing for reverse fault on resonant compensated system.

Immune to loads with 220Hz frequency range

The technique is immune to load current and will restrain from operation during very rare load conditions whose zero

sequence voltage and current might have 220Hz. The zero sequence over voltage starting elements employed within the technique will prevent operation under load conditions.

The performance of the Relay

This technique has already been implemented into P14x relays by ALSTOM Grid Limited. The performance of relay in all cases the relay are listed in table 1.

Table 1 the performance of relay P14x tested by Russian comrades

Test	Compensation	Fault	direction	FA_TRAN	FA_STEADY	DIR_FWD	DIR_RVS	ALARM	
M_0_01	None	Direct Earth Fault (Steady)	External	N	Y	N	Y	Y	OK
M_0_02	Resonant	Direct Earth Fault (Steady)	External	N	Y	N	Y	Y	OK
M_0_03	None	Direct Earth Fault (Steady)	Internal	N	Y	Y	N	Y	OK
M_0_04	Resonant	Direct Earth Fault (Steady)	Internal	N	Y	Y	N	Y	OK
M_0_05	None	Arc Fault (Steady)	Internal	N	Y	Y	N	Y	OK
M_0_06	Resonant	Arc Fault (Trans)	Internal	Y	N	Y	N	Y	OK
M_0_07	None	Arc Fault (Steady)	External	N	Y	N	Y	Y	OK
M_0_08	Resonant	Arc Fault (Trans)	External	Y	N	N	Y	Y	OK
M_0_09	50% under compensation	Arc Fault (Steady)	External	N	Y	N	Y	Y	OK
M_0_10	50% under compensation	Arc Fault (Steady)	Internal	N	Y	Y	N	Y	OK

CONCLUSIONS

This paper presents a new technique for detecting the direction of single-phase-to-earth fault on a Petersen’s coil compensated distribution system. Unlike the other techniques, such as first-half-wave method, active power or conductivity method, etc, the proposed technique does not require special hardware with higher sampling rates, nor higher accuracy measurements. It can be implemented in the common feeder relays. The tests on the relay implemented such technique show that it can make a correct decision on the fault direction.

REFERENCES

[1] V. Leitloff, R. Feuillet, and L. Pierrat, “Determination of the Phase-to-Ground Admittance in a Compensated MV Power Distribution System,” Proceedings of the 28th Universities Power Engineering Conference – UPEC ’93, Vol. 1, Stafford, United Kingdom, September 21–23, 1993, pp. 73–76.

[2] G. Benmouyal and J. Roberts, “Superimposed Quantities: Their True Nature and Their Application in Relays,” Proceedings of the 26th Annual Western Protective Relay Conference, Spokane, WA, October 26–28, 1999.

[3] V. Leitloff and R. Feuillet, “Design and Realization of a Control Unit for Compensated MV Distribution Systems,” Proceedings of the IEEE/KTH International Symposium on Electric Power Engineering – Stockholm Power Tech, Stockholm, Sweden, June 18–22, 1995, pp. 252–257.

[4] Siemens Manual Book, Transient earth fault relay. Version, 10.2002.