

## CENTRALISED BUSBAR PROTECTION FOR SMARTER GRIDS

Philippe BRUN  
ALSTOM Grid SAS, Montpellier  
[philippe.brun@alstom.com](mailto:philippe.brun@alstom.com)

Sankara SUBRAMANIAN  
ALSTOM Grid Limited, UK  
[sankara.subramanian@alstom.com](mailto:sankara.subramanian@alstom.com)

### INTRODUCTION

The specifications and expectations of busbar protection at distribution grid have increased over the last few years thanks to increasing levels of interconnections at the distribution grid due to distributed generations. Economical versions of Numerical busbar protection have become a norm at the distribution levels. According to lessons learned and in order to meet the expectation of both the performance and cost numerical version of centralised busbar schemes have been evolved.

### CHALLENGE FOR LOW IMPEDANCE

Some of the challenges that low impedance busbar current differential face are reliability and security.

Low impedance based busbar protection schemes must be able to operate in the presence of significant CT saturation for internal faults. At the same time for the external faults must remain stable under heavy CT saturation. Unlike the use of stabilising resistor for high impedance principle low impedance must overcome such scenarios with the use of characteristics.

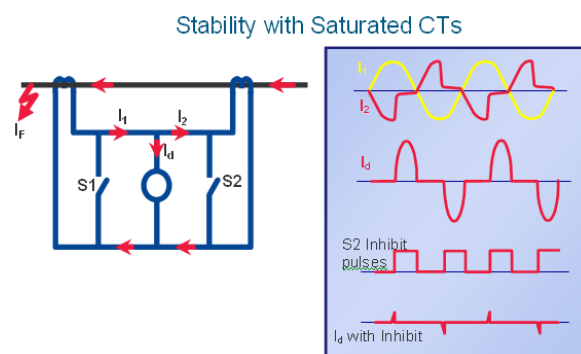

Low impedance busbar protection remains stable under saturated CT conditions for external faults by employing various different techniques such as,

- Waveform Gap Analysis technique
- Estimation of flux levels
- Using phase comparison technique

Operation with Saturated CTs

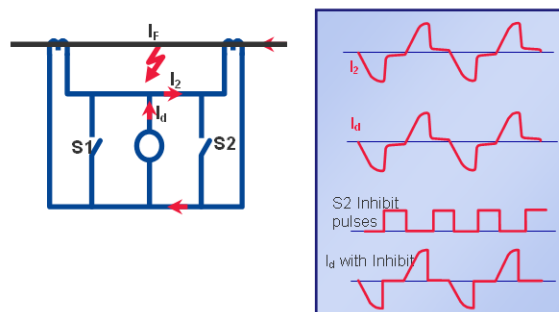

More critically various different techniques (such as fault detectors) help in unblocking the protection to enable operation during evolving external to internal fault conditions. Thus, penalty on operating times for such faults.

Other advantage of low impedance protection is that both the main zone differential and check zone utilises the same CT core. Both main and check zone protection could work utilising different operate criteria in this case.

But in order to make correct decision of faults in zones it is still necessary to have information of auxiliary contacts from the CB similar to the high impedance principle.

### NUMERICAL BUSBAR PROTECTION WITH CONVENTIONAL CT'S ON A CENTRALISED ARCHITECTURE

The new centralised numerical busbar protection includes now higher CPU power. Consequently, it can reach same performances and functional requirements for protected zones than former decentralised numerical busbar protection. It covers up to 4 zones plus check zone and 18 terminals handling simple to complex topologies of distribution and transmission substations. In distribution grids as more and more interconnections are happening due to growth in distributed generation such as wind and solar power there is an increased need to maintain and transmit power without higher investment and the only way this will happen is by having complex busbar arrangements that could meet the combination of economics and at the same time helps in transmitting increased power.

The busbar protection from the author’s company will be able to protect for instance the following busbar topologies.

- [1] Single busbar with no bus section
- [2] Single busbar with bus section isolator
- [3] Single busbar with bus section breaker and one bus CT
- [4] Single busbar with bus section breaker and two bus CT
- [5] Double busbar topology with one CB and two isolators per terminal
- [6] Double bus and bus coupler with one CT
- [7] Double bus and bus coupler with two CT
- [8] Single busbar with bus section breaker and two bus CT
- [9] Double busbar topology with one CB and two isolators per terminal
- [10] Double bus and bus coupler with one CT
- [11] Double bus and bus coupler with two CT
- [12] Double bus and bus coupler with one CT and transfer bar

In all the above topologies different scenarios that exist have been covered with the numerical busbar function by adopting with settings and configurations. The above mentioned topologies are mostly covered in distribution system covering up to 4 zones and 18 terminals without penalising on the operating times of the protection.

An example topology is shown below in fig 1. This complex topology shown is a double busbar with transfer bar and how dynamic terminal switching between BB1, BB2 and transfer bar takes place.

Based on this complex substation topology, fig 2 depicts typical numerical scheme for new numerical centralised busbar protection and current decentralised busbar protection.

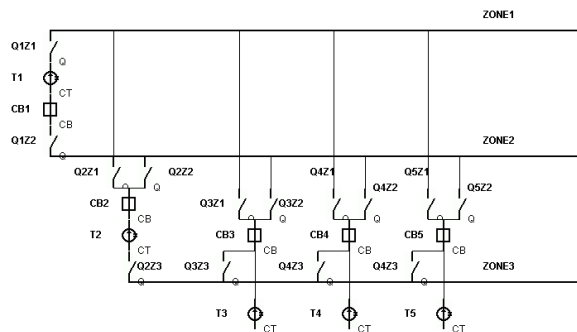

Figure 1: Double busbar with transfer bar topology

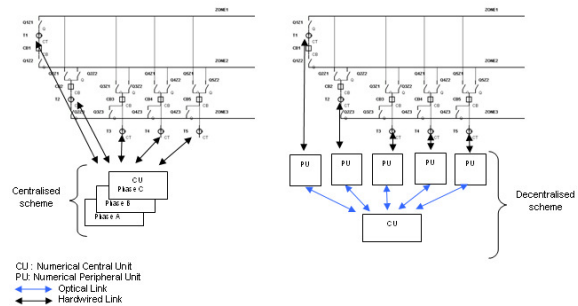

Figure 2a: Centralized BBP scheme      Figure 2b: Decentralized scheme

The customer is able to draw / configure the topology in the software tool that he needs and when downloaded into the product and is able to configure the relay according to the required topology. The relay auxiliary contacts are still required for ensuring correct analysis of currents within the topology. Advanced information for topology processing is still preferred. The dynamic synoptic tool usually provides information on current values on per phase basis of each feeder and the latest status update on the topology. The algorithm resident in the IED takes a deterministic time for topology to be updated.

The centralised busbar scheme provides other advantages such a one CT for both main and check zones, smaller CT requirements, sharing of CT with other protection functions, no CT switching needed and hence no risk of open circuit CTs, simpler wiring requirements, different ratios of CT possible due to bias slope.

The latest centralised busbar protection from the authors company has been employed with good CT saturation technique that allows maintaining secured operation under external fault scenarios. The technique employed in the function is such that when the relative phase angle of all currents per phase are compared within the discriminating zone all currents must be within  $\pm 90^\circ$  for tripping. Additionally only currents exceeding a settable threshold are considered. Under saturated CT condition this may cause differential and check zone elements to operate, but the phase comparison technique can correctly operate whether the fault is internal or external and permit/block tripping. Also evolving faults do not cause significant delay to tripping. In figure 3a & 3b phase comparison technique functioning is shown.

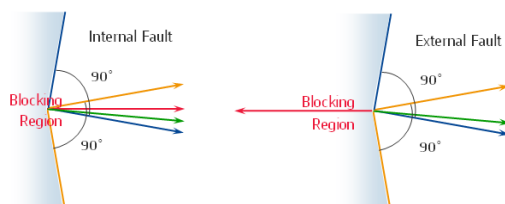

Fig 3a Phase comparison internal faults

Fig 3b Phase comparison external faults

The centralised numerical busbar protection is equipped with other standard functionalities such as the supervision of CT secondary circuits and circuit breaker failure features. Additional tripping criterias based on under voltage function are added to the trip decision to provide secured trip decision.

With a numerical busbar scheme a user gets the additional benefits of engineering complex schemes using powerful scheme logics resident in the product. The product could be configured using the same tool that is used to configure other numerical protection available from the author's company. One of the key requirements with all numerical busbar protection is the use of software tool to mimic system topology and how that will provide the dynamic status update for changing busbar topologies. The numerical busbar protection from the author's company has a comprehensive topology viewer that aid's the user with all information about the changes that happen in real time.

### NUMERICAL PROTECTION WITH SAMPLE VALUE INPUTS (IEC 61850-9-2LE)

IEC 61850-9-2LE defines Process Bus communications between the different components of the substation automation system. The IEC 61850-9-2LE interface allows IEDs to communicate with the Process Bus and receive IEC 61850-9-2LE data from Merging Units. The Merging Units digitise analogue values from conventional CTs and VTs, replacing analogue inputs. This provides safer and more economical cross-site communication using fibre optics. It also allows the IED to receive current and voltage sampled data through Merging Units from non-conventional instrument transformers such as optical and Rogowski devices.

The 9-2 implementation from the author's company has been designed to be especially resilient and reliable in the presence of interference, such as latency, jitter and missing or suspect data.

The way the implementation works is IEC 61850-9-2LE interface receives 80 Sampled Values per cycle from the Process Bus. This is the same for both 50 and 60 Hz. The IEC 61850-9-2LE interface then resamples these Sampled Values to make the data appear the same to the IED as analogue signals would do on its normal inputs from CTs and VTs.

The resampling frequency depends on the IED.

### DATA QUALITY

Any degradation in the measurement or transmission of Sampled Values means that the protection function of the IED cannot operate correctly. Therefore to be able to detect questionable data, the IEC 61850 protocol assigns quality flags to each channel in the Sampled Value frame. Data frames from a typical Logical Node with four voltages and four currents [VA, VB, VC, VN, IA, IB, IC, IN] have quality flags for each of the channels. The IED adapts the behaviour of protection functions according to the quality flags.

The front panel of the IED shows the quality flags for each of the analogue channels configured. The number of analogue channels depends on the IED type; unused channels appear as 0. IEDs which have an IEC 61850-9-2LE interface use the quality flags on Sampled Values. For protection functions to work correctly, the Sampled Values arriving at the IED should have Good quality, as defined by the IEC 61850 standard. Samples that have an Invalid or Questionable quality could result in unacceptable performance from the protection functions.

The way that the IED treats questionable data is user configurable. However, the default setting can be changed to Trust Questionable Data for one or more specific type, such as Out Of Range. This setting is common for all Logical Nodes and all channels configured in the IED. It can be used to analyse the impact of questionable data on the performance of the IED.

A protection function operates normally when all the necessary Sampled Value inputs are available and have a Good quality flag. When the flag for one or more of the Sampled Value inputs changes to Invalid or Questionable, the protection function is inhibited. The IED can be configured to ignore the Questionable flag but the protection function is not inhibited. The protection function returns to Normal state when the quality flags for all the necessary Sampled Value inputs are Good. The quality flags can change with each sample, therefore there is a one-cycle transition delay between the Normal and Inhibit states for each protection function.

### NUMERICAL BUSBAR WITH SAMPLE VALUE INPUTS (9-2 STREAM) ON A CENTRALISED ARCHITECTURE

A typical arrangement of current measurements via sampled values to a numerical centralised busbar protection from the author's company is shown here in Fig 4.

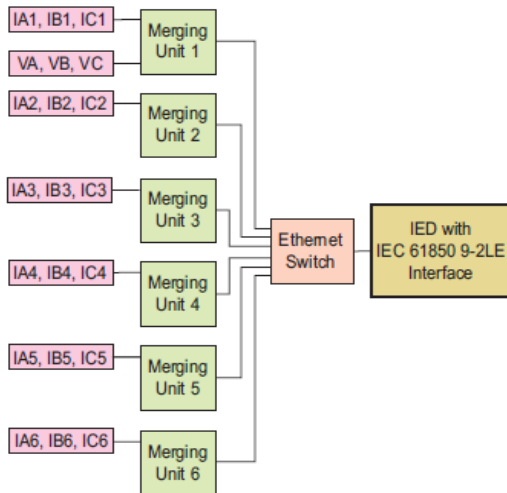

Fig 4: An example scheme of distributed Busbar architecture receives sampled values from 6 Merging unit

The performance claims in terms of operating times of Numerical busbar protection on a centralised scheme with conventional CT inputs compared with that of sampled values inputs coming in 9-2 stream are similar. It is understood the samples received at the IED's inputs are time synchronised values

## CONCLUSION

With the evolution of numerical technology, protection relay manufacturers have the responsibility of taking the benefits of such technologies to the end users by producing simple solutions within the framework of protection philosophies. The authors in this paper have tried to do justice by explaining the evolution of numerical busbar schemes on centralised architecture their benefits and advantages of such. The authors have also tried to bring out to the reader of how technology is evolving in terms of digital substation and what efforts are being made from the author's company in terms of adapting to such technology by showing architectures of centralised numerical busbar protection working in a digital substation.