

## ACCURATE TRACK MODELLING WITH SKIN-EFFECT FOR PROTECTION IMPROVEMENT IN DC RAILWAY SYSTEM BASED ON RTDS

Xiaoming Song  
Beijing Jiaotong University  
China  
12121535@bjtu.edu.cn

Jinghan He  
Beijing Jiaotong University  
China  
jhhe@bjtu.edu.cn

Chenyang Dong  
Beijing Jiaotong University  
China  
11125704@bjtu.edu.cn

Xia Yang  
Alstom Grid Technology Center, China  
China  
autoy.yang@alstom.com

Brian Kirby  
Alstom Automation  
UK  
brian.kirby@alstom.com

David Writer  
Alstom Automation  
UK  
david.writer@alstom.com

### ABSTRACT

*This paper presents an accurate track modelling for fault current analysis of DC railways based on RTDS (Real-time Digital Simulator). With the introduction of skin effect for rails during the short-circuit transient conditions, an integrated RTDS simulation model of short-circuit fault is proposed. The model includes a novel method based on voltage step series under the equivalent cylindrical conductor of rail to obtain the current series response. By comparing and investigating the waveforms of remote short-circuit current with and without skin effect, the paper pointed out the difference between these two currents. Based on this, the failure analysis can be done more accurately which is beneficial to the accurate setting of DC protection equipment and provides an improvement to the protection system.*

### INTRODUCTION

With the rapid development of urban railway transit system, new problems for the security and reliable operation of the power supply system have been brought up. As the density of the train increases, the traction load impedance is more similar to the remote short-circuit impedance, making it difficult to distinguish the starting current of locomotive from that caused by a remote fault or a high resistance grounding fault. Such faults must be detected to prevent them from being a potential cause of tunnel fires.

The protection devices based on rate of rise (di/dt) detectors differentiate between train starting currents and remote fault currents by the persistence of the initial rate of rise of the current/time profile are widely used. A variation of this relay includes differential increase detection which monitors the duration of a change in current. Track under-voltage relays detect remote fault conditions by the drop in the track section voltage and do not measure any parameter of the fault current itself. They are usually sited at both ends of a track section, and in the middle to extend the range. If such detectors are set too sensitive, nuisance trips will occur, even with normal loading, resulting in loss of supply and hence disturbance to passenger service. Alternatively, if the setting is too

coarse, remote distance faults remain undetected. Therefore, accurate detection of a DC remote short-circuit fault has been a problem in DC transit system. New protection algorithm development is urgently needed and accurate track modeling for fault current analysis becomes the central topic in DC feeder protection researches.

In order to design new systems and to use remote fault detection devices with confidence, it is necessary to understand the physical phenomena of skin effect, which determines the specific shape of current profiles for remote faults. When remote short circuit occurs, the variation of time constant which increases as the fault progresses implies the impedance of the power feed system changes during transient conditions. The variation is the same as the results of tests in Docklands light railway and Hong Kong MTRC<sup>[1,2]</sup>.

So far, many researches of simulation calculations for fault current analysis with skin effect have been done. They can be divided into three main categories. The time domain calculation method was first put forward by Carslaw et al. to solve the heat conduction problem of a conductor<sup>[3]</sup>. The method was applied into skin effect calculation by Edward J. Tuohy<sup>[4]</sup>, and achieved good effect. Frequency domain calculation method<sup>[5,6]</sup> converts Bessel equation into frequency domain, calculates the circuit as a whole and uses the inverse Fourier transform method to convert the results back into the time domain. Conductor segmentation method<sup>[7-9]</sup> divides the entire conductor into limited sub-sections. Through the analysis of the electromagnetic relations between the subdivided conductors to establish the inductance and resistance calculation matrix, the overall impedance expression of the conductor is obtained. This method can get accurate results in short circuit calculations.

This paper shows a novel method based on voltage step series under the equivalent cylindrical conductor of rail to obtain the current series response. Based on this, the paper outlines an integrated RTDS simulation model of DC railway system with the consideration of skin-effect. The technique of CBuilder application in RTDS to create the simulation module as a user-defined component is also proposed.

### DC RAILWAY SYSTEM CONFIGURATION

A typical DC railway system is shown in Fig. 1. An AC supply is transformed and rectified to provide the correct DC traction voltage, for connection to the substation positive and negative busbars. Track feeders provide an output connection to the third rails or catenary, through track feeder circuit breakers. The track feeder circuit breaker at each end of a faulted section must operate to isolate the fault. Each substation feeds from a common DC busbar through DC circuit breaker in both directions. The feed is separated by articulated neutral section insulator.

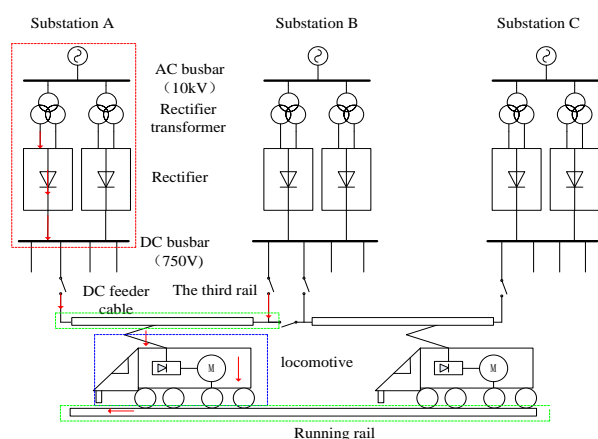

Fig.1. Structure of DC railway power supply system.

The system is complex, as it includes power electronic converters, rails, electrical motors, controlling system, and mechanical system. However, RTDS provides a promising real time simulation tool for modeling such a system, since it allows not only the analysis of an electrical circuit but also its interactions with mechanical, thermal, control and other systems. The rail system cannot directly model with the latest component library. Thus it is necessary to model with CBuilder, which allows users to build their own models by designed functions.

The modeling of DC transit system is implemented based on the following principles:

- The track section is energized by two substations. Each substation has two inlet wires.
- Each traction substation has two sets of 12-pulse rectifier units and the winding of two rectifier-transformers have  $\pm 7.5^\circ$  phase-shifting, to form a 24-Pulse equivalent rectification system.
- An accurate time dependent model for the whole track system is realized as a controlled current source. Equivalent resistance and inductance of rails are used to substitute the transient parameters of the contact wires and the running rails. They are constantly changing with time during the short circuit transient conditions.

### THEORETICAL CONSIDERATIONS

There are two criteria that can be used to define the radius of an equivalent conductor of circular cross section for rails. For high-frequency AC calculations, the cylinder can be defined as having the circumference equal to the rail periphery, because the skin effect forces current to be conducted along the conductor periphery.

$$R = \frac{P}{2\pi} \tag{1}$$

P- Perimeter of the rail, R- Equivalent radius of the rail.

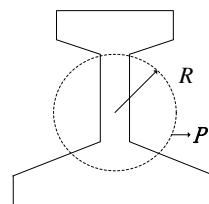

Fig.2. Equivalent circular cylinder conductor of rail.

Maxwell's electromagnetic field equations for a circular cylinder conductor can be deduced as

$$\nabla^2 J = \mu\sigma \frac{\partial J}{\partial t} \tag{2}$$

$\mu$  = Permeability

$\sigma$  = Conductivity

$U(t)$  = Voltage of unit circular cylinder conductor

$I(t)$  = Current of unit circular cylinder conductor

$J(r,t)$  = Current density

$E(r,t)$  = Electric field intensity

The partial differential equation is:

$$\frac{\partial^2 J}{\partial r^2} + \frac{1}{r} \frac{\partial J}{\partial r} = \mu\sigma \frac{\partial J}{\partial t} \tag{3}$$

The skin effect impedance is derived from Maxwell's equations using suitable initial and boundary conditions. Closed-form equations can only be formulated for conductors of circular cross-section. A step of electric field intensity is applied to the surface of a cylinder conductor. The solution is

$$J(r,t) = J_s \left\{ 1 - 2 \sum_{n=1}^{\infty} \frac{J_0(x_n r)}{\alpha_n J_1(x_n)} e^{-x_n^2 t / \mu\sigma} \right\} \tag{4}$$

$J_0$  = Bessel functions of the first kind of order zero

$J_1$  = Bessel functions of the first kind of order one

$x_n$  = roots of the equation  $J_0(x_n) = 0$

Thus the current of conductor is

$$I(t) = \pi R^2 J_s - 4\pi R^2 J_s \sum_{n=1}^{\infty} \frac{1}{(x_n)^2} e^{-x_n^2 t / \mu\sigma R^2} \tag{5}$$

R= the radius of the circular cylinder conductor

During  $t = 0$  and  $t = \infty$  scenarios, the current can be obtained based on the transient internal resistance and

internal inductance calculation.

[10] defines the transient resistance with power loss:

$$R_{int1} = \frac{\sum_{n=1}^{\infty} \left( \frac{1}{x_n} \right)^2 \left( 1 - e^{-x_n^2 t / \mu \sigma R^2} \right)^2}{4\sigma \pi R^2 \left[ \sum_{n=1}^{\infty} \frac{1 - e^{-x_n^2 t / \mu \sigma R^2}}{x_n^2} \right]^2} \quad (6)$$

A similar expression for transient resistance for short time is derived to be

$$R_{int2} = \frac{\int_0^{1/4} \left[ \operatorname{erfc} \sqrt{\mu \sigma r^2 / 4t} \right]^2 dr}{4\pi R^2 \sigma \left[ \int_0^{1/4} \operatorname{erfc} \sqrt{\mu \sigma r^2 / 4t} dr \right]^2} \quad (7)$$

External inductance<sup>[11]</sup> is easily derived for a given geometrical arrangement of conductors provided that the magnetic fields can be defined as cylindrical with concentric circles of flux density.

The voltage of conductor can now be calculated with previous expressions of transient resistance and inductance, which ignored mutual inductance:

$$U = R_{int} I + L_{int} \frac{dI}{dt} \quad (8)$$

### CALCULATION OF SHORT CIRCUIT CURRENT

This paper uses a step series method to realize numerical calculation of skin effect. The current response generated by step superimposed voltage signal can be obtained using Eq.5. Analysis has shown that the magnitudes of step voltage and current response have direct proportion. Also, the current response is determined only by the voltage change. Therefore, a novel method of step voltage series superposition has been put forward.

The steps of the method are:

(i) In the form of discrete sampling, the voltage signal  $f(t)$  can be expressed by

$$f[n] = f(n \cdot T) \quad (9)$$

$n$  = number of sample point,

$T$  = sample time.

The sampling voltage signal can also be expressed by unit step signal, as

$$f[n] = \sum_{n=0}^{\infty} \{f(n \cdot T) - f[(n-1) \cdot T]\} \cdot U(n \cdot T) \quad (10)$$

In this function, when  $n = 0$ :

$$f[(n-1) \cdot T] = 0 \quad (11)$$

(ii) The current response generated by  $U(n \cdot T)$  through Eq.5 is  $I(t - n \cdot T)$ . Therefore, the step voltage signal  $\{f(n \cdot T) - f[(n-1) \cdot T]\} \cdot U(n \cdot T)$  corresponds to the current  $\{f(n \cdot T) - f[(n-1) \cdot T]\} \cdot I(t - n \cdot T)$ .

(iii) Calculate all the current response of every step voltage signal and make these currents combined in time domain. The result can be expressed as

$$i[n] = \sum_{n=0}^{\infty} \{f(n \cdot T) - f[(n-1) \cdot T]\} \cdot I(t - n \cdot T) \quad (12)$$

This method establishes the relationship of current and voltage, so that the calculation of skin effect becomes easier.

### SIMULATION RESULTS ANALYSIS

The paper outlines an integrated RTDS simulation model of short-circuit fault in DC railway system. With the consideration of skin-effect for rails, the CBuilder application in RTDS is used to create the simulation module as a user-defined component. The time varying impedance of rail can be equivalent to a controlled current source which is realized by C code.

A comprehensive analysis of the impedance seen by a substation for a remote-fault short circuit which is dominated by the series resistance and inductance of the steel rail is provided. In order to research the performance of skin effect, remote short-circuit fault is applied at different distances. The short-circuit currents, voltage and time constant with skin effect are presented by Figures 3, 4 and 5.

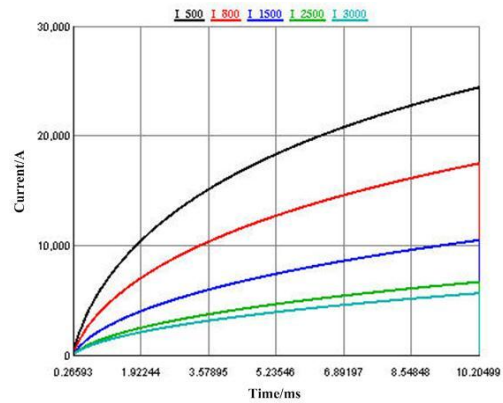

Fig.3. Short-circuit currents under different distance.

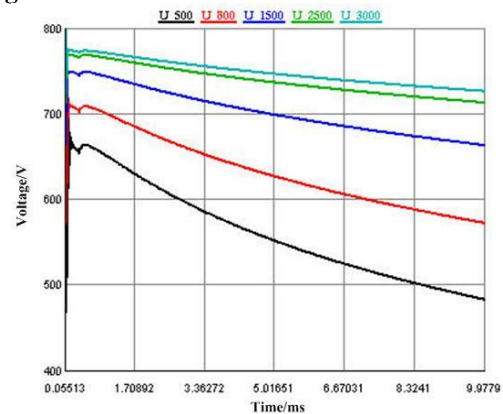
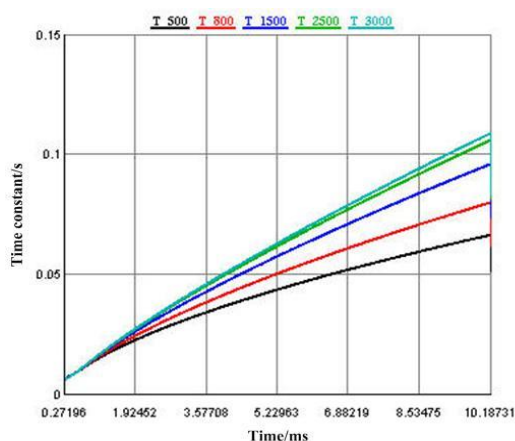

Fig.4. Short-circuit voltages under different distance.



**Fig.5.** Time constant under different distance.

The variation of time constant which increases as the fault progresses implies the impedance of the power feed resistance is larger than the steady-state resistance, and the initial inductance is smaller than the steady state inductance.

The comparison between short-circuit currents with and without skin effect are presented by Fig. 6 (distance=2.5km). There is a disparity between the two curves that the waveform with skin-effect rises up faster than the other one; while the magnitude change to the opposite trend over time.

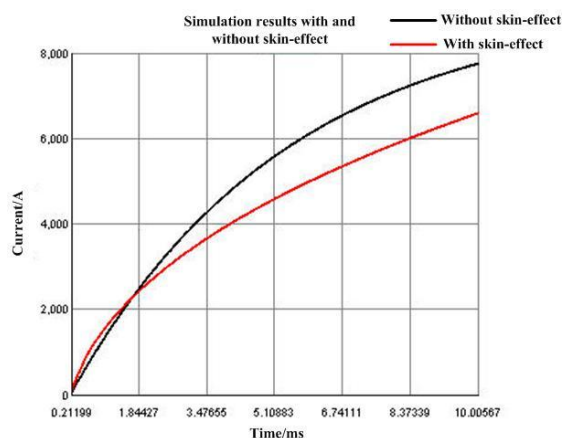

**Fig.6.** Short-circuit currents with and without skin-effect

## CONCLUSION

This paper presents an integrated RTDS simulation model of short-circuit fault which can be used to extend previous skin-effect studies. The simulation can be easily rebuilt according to different substation construction and track parameters with the rail block considering skin effect built by CBuilder. Furthermore, a new calculation method of skin effect on time domain has been presented. With

the factor that voltage signal could be constructed by series step voltage, it is possible to calculate the current response based on series currents produced by the step voltage signal.

By comparing and investigating the different waveforms of short-circuit currents with and without skin-effect, the character of each waveform have been identified. The paper also pointed out the character of the feeder voltage and time constant. Based on this, the failure analysis can be done more accurately which is beneficial to the accurate setting of DC protection equipment.

## REFERENCES

- [1] J.C. Brown et al. "Calculation and measurement of rail impedances applicable to remote short circuit fault currents". *IEE Proceedings-B*. Vol. 139, No. 4, JULY 1992, pp.295-302.
- [2] J.C. Brown, J. Allan, B. Mellitt, "Calculation of remote short circuit fault currents for DC railways", *IEE PROCEEDINGS-B*, Vol. 139, No. 4, JULY 1992, pp. 289-294.
- [3] Carslaw and Jaeger, 1947, *Conduction of Heat in Solids*, 1st ed. London: Oxford University Press.
- [4] Edward J. Tuohy, Thomas, T.H., and Fullerton, H.P., "Transient resistance of conductors", *IEEE Trans*, 1968, PAS-87, (2). pp. 455-462.
- [5] R.J. Hill, D. C. Carpenter, "Modelling of nonlinear rail impedance in ac traction power systems", *IEEE Trans on Power Delivery*, Vol. 6, No. 4, Oct 1991.
- [6] R.J. Hill, D. C. Carpenter, "Determination of rail internal impedance for electric railway traction system simulation", *IEE Proc.-B* 1991, Vol.138 (6):311-321.
- [7] P. Silvester, modal theory of skin effect in single and multiple turn coils, *IEEE Transactions on Power Apparatus and Systems*, 1970, Vol. PAS-89
- [8] P. Silvester, AC resistance and reactance of isolated rectangular conductors, *IEEE Transactions on Power Apparatus and Systems*, 1967, Vol.PAS-86(6):770-774
- [9] P. Silvester, The accurate calculations of skin effect in conductors of complicated shape, *IEEE Transactions on Power Apparatus and Systems*, 1968, Vol. PAS-87 (3):735-741
- [10] Edward J. Tuohy, Thomas, T.H., and Fullerton, H.P., "Transient resistance of conductors", *IEEE Trans*, 1968, PAS-87, (2). pp. 455-462.
- [11] L Yu, J H He, J Hu, Z Q Bo, M X Li, T Yip, A Klimek., "Accurate track modeling for fault current on DC railways based on MATLAB/Simulink", *PESGM2010*. Minnesota USA. July 25-29, 2010