

UNDER FREQUENCY LOAD SHEDDING SCHEME BASED ON INFORMATION SHARING TECHNOLOGY

Dandan BAI
Beijing Jiaotong University – China
11121572@bjtu.edu.cn

Jinghan HE
Beijing Jiaotong University – China
jhhe@bjtu.edu.cn

Xia YANG
Alstom Grid - China
Autoy.yang@alstom.com

Brian KIRBY
Alstom Grid – UK
Brian.kirby@alstom.com

David WRITER
Alstom Grid – UK
david.writer@alstom.com

Lin LIU
Beijing Jiaotong University – China
11117363@bjtu.edu.cn

ABSTRACT

Under frequency load shedding (UFLS) has a vital role in its effectiveness for preserving system stability for emergency condition. Conventional load shedding schemes have a serious problem of recognizing the disturbance location and amplitude. This paper proposes a centralized decision-making and distributed revising UFLS scheme based on the use of information sharing technology. From the real-time information, the dispatch center delivers the amount of shedding load and the fault place to every station UFLS control center. The station UFLS control center will shed load according to the proportion of power shortage transferred from the dispatch center. The scheme has been verified through programming and simulation. By using the proposed technique, UFLS devices can shed load precisely and effectively to prevent system from collapse during large disturbances.

INTRODUCTION

Under frequency load shedding (UFLS) has a vital role in its effectiveness for preserving system stability for emergency condition [1]. Therefore the importance of accuracy and speed of such a scheme is paramount. Power system becomes more and more complex, but conventional load shedding schemes have a serious problem of recognizing the disturbance location and amplitude [2]. Thus an accurate and adaptive scheme to curtail the minimum amount of load with smooth, fast and reliable restoration of system frequency is required to be devised [3-4].

The advent of smart grid and intelligent substation provides a platform for the sharing of all kinds of information in the power system. Thus the power shortage following a disturbance can be measured instantaneously. The current, voltage and on-off state of breakers are shared in real time via sample values (SV) in IEC61850's process bus and GOOSE network. This paper proposes a centralized decision-making and distributed revising UFLS scheme based on the use of information sharing technology.

SYSTEM DYNAMIC FREQUENCY CHARACTERISTICS

Time domain dynamic simulation analysis is the modelling of generator, excitation system, governor, prime mover, boiler and load in actual power system, parameter identification, and using the simulation software to simulate the dynamic change of the system frequency, voltage, and other variables after all kinds of faults. With the power system becoming large and complex, and with the using of more and more dynamic elements, the analysis of the system is becoming difficult. Time domain dynamic simulation analysis method can faithfully reflect frequency dynamic process of each node during the under frequency load shedding conditions by considering the influence of each element to the dynamic change of system frequency, and it has become the mainstream approach to optimize the UFLS allocation. The following section studies the key factors that influence the system dynamic characteristics when the system is lacking active power based on the dynamic domain simulation analysis method.

Modelling of 36 nodes system

A system model of 36 nodes was built based on Power System Analysis Software Package (PSASP) and the single line diagram is shown in Fig. 1.

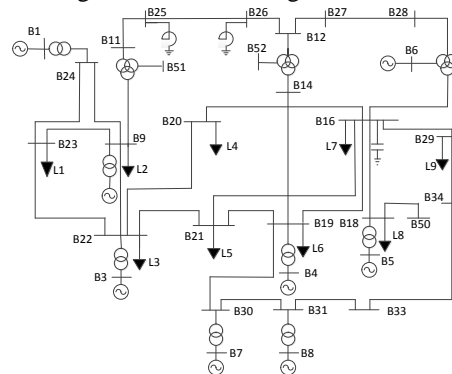

Fig. 1. the single line diagram of 36 nodes
There are 8 generators, 9 loads, and 26 lines in this system. The generators are all employed with governors except the ones connecting to B1 and B6, and are all

engaged with voltage regulators except the one connecting to B1. Each load point constitutes a station UFLS control centre.

Different shedding place

Conventional UFLS strategy based on their locally measured frequency drop generally takes actions to shed load without considering the impact on the whole system. The composition of load and its characteristics change with the location, which may influence the frequency movement. Frequency behaviour of system for shedding two 260 MW loads, one on B16, and the other on B9 following a sudden 300 MW overload on B2 is simulated. As can be seen in Fig. 2, the frequency responses are different even though the amount of load shed in different locations are the same..

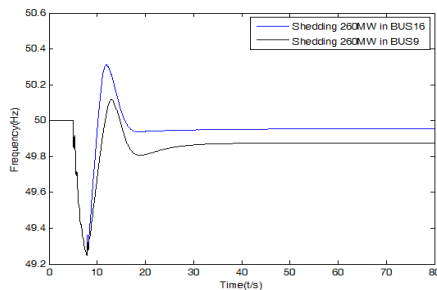

Fig.2 The recovery curve with different shedding locations

Different shedding capacity

Frequency as a proxy for system active power balance has an obvious variation for different shedding capacity. If the shedding capacity is closer to the active power shortage, the steady state frequency will be closer to the nominal value. This fact is easily observed in Fig. 3. In Fig. 3 the fault is the same as that in Fig. 2 following a 150 MW or a 250 MW load shed on B16.

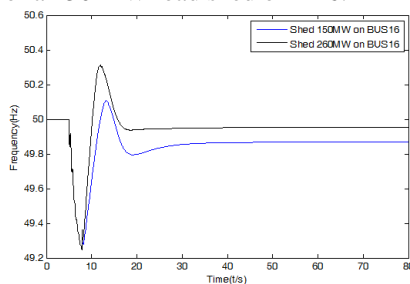

Fig.3 The recovery curve with different shedding capacity

Effects of different load frequency regulation factors K_L

Load frequency regulation coefficients can be defined as the rate of the change of the load's active power respect to frequency^[5]. Different load have different frequency regulation abilities when system frequency changes. Take off all the governors in this 36 nodes system, and set the frequency regulation factor of whole system load at 1, 1.5, or 3. Fig. 4 describes system frequency behaviour on

these three occasions after a 300 MW disturbance on B2. It can be seen that load 1 has a slower response and the highest steady state frequency. Load with a bigger frequency regulation factor is more sensitive to frequency change. It absorbs more active power from power sources after a frequency deviation. Therefore it is preferable to shed the load with smaller regulation factor than the bigger one.

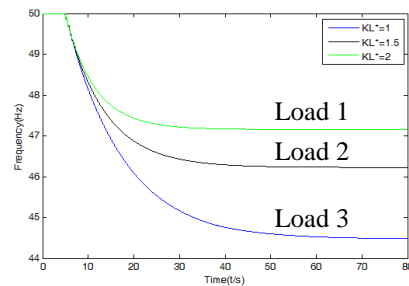

Fig.4 The recovery curve with different adjustment effect frequency coefficient

THE UFLS STRATEGY BASED ON INFORMATION SHARING

The UFLS algorithm put forward in this paper has a big difference from the current widely used UFLS scheme by making full use of real-time steady state and transient information of the system. The architecture is described in the Fig. 5.

From the real-time information, the dispatch centre can obtain the output of every power plant, pumped storage load and other loads, line flow, and the network structure. Based on these data, the real-time load flow of the whole system can be easily calculated. At the same time, the dispatch centre bears the recognition of system random accidents. Using switching status of the entire network and the real-time load flow, the fault location and disturbance amplitude can be recognized. After processing and computations based on certain principles, the centre delivers the amount of shed load and the fault place to every station UFLS control centre.

The station UFLS control centre will shed load according to the proportion of power shortage transferred from the dispatch centre. In order to ensure the shed load, the station UFLS centre may use the current of main feeders to estimate the load characteristics, use the load flow to identify the amount of real-time load, and decide the shedding order based on the combination of the load characteristics and the real-time load.

The sequence of the new load shedding scheme based on information sharing technology comprises four parts:

- 1) Recognizing the fault magnitude and decide the shedding capacity

The control centre always monitors the switching state in the whole system, and controls the real time power flow at the same time. It can calculate the active power shortage by identifying the tripped location and can reference to

the instantaneous power flow right after generators tripping or tie line fault blackouts. Suppose that the system has been given full play of spinning reserve, the total shedding capacity is equal to:

$$\Delta P_{shed} = P_{\Delta} - P_{adj} \quad (1)$$

where

P_{Δ} is the amount of generation outage

P_{adj} is the amount of generation regulation reserve within the system capable to maintain frequency as long as it is greater than P_{Δ} .

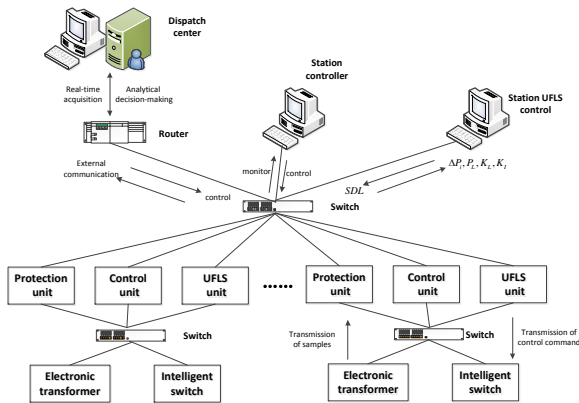

Fig.5 Architecture of UFLS based on information sharing technology

2) Calculate the load shedding regional distribution map
The shed load in every station UFLS control centre will be classified as P_I , P_{II} , and P_{III} , in order of importance. The control centre will calculate the load shedding regional distribution map using classification information from all station UFLS control centres described in Fig. 6.

$$\begin{aligned} \Delta P_{III} &= P_{III1} + P_{III2} + \dots = \sum_{i=1}^m P_{IIIi} \\ \Delta P_{II} &= P_{II1} + P_{II2} + \dots = \sum_{i=1}^m P_{IIi} \\ \Delta P_I &= P_{I1} + P_{I2} + \dots = \sum_{i=1}^m P_{Ii} \end{aligned} \quad (2)$$

Where, m is the total of station UFLS control centres.

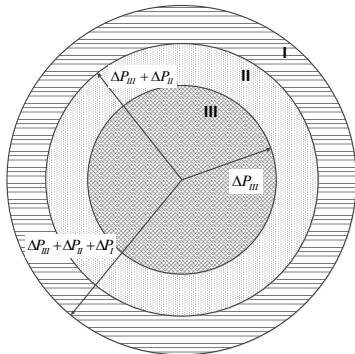

Fig.6 Load shedding regional distribution map
Furthermore, the station control centre calculates the real time load frequency regulation factor K_{Lj} of the feeders that need to shed in different ranking of importance based

on Least Square Curve Fitting (LSCF), and then selects the sequence based on combination of load shedding cost K_{ej} and load usage rate K_{rj} . Therefore, a feeder's overall load weighting factor can be defined as:

$$K_j = K_{Lj} K_{ej} K_{rj} \quad (3)$$

Feeder j with smaller K_j will have more chance of being shed.

3) Determine load shedding location and value
After establishing the magnitude of the disturbance, we face one of these conditions:

a) $\Delta P_{shed} < \Delta P_{III}$

It means that the load shedding capacity is in the innermost circle. To have the most effective scheme, this amount of load shed is distributed proportional to corresponding overall load weighting factor ranking. Therefore the shedding capacity for the station UFLS control centre named i is equal to:

$$P_{LDi} = \frac{\Delta P_{shed}}{\Delta P_{III}} P_{IIIi} \quad (4)$$

b) $\Delta P_{III} \leq \Delta P_{shed} < \Delta P_{III} + \Delta P_{II}$

In this state, the load shedding capacity is in the middle circle, thus whole station UFLS control centres will trip all load of class III. The rest of the load that need to be shed will be assigned proportional to every station UFLS control center:

$$P_{LDi} = \frac{\Delta P_{shed} - \Delta P_{III}}{\Delta P_{II}} P_{IIi} \quad (5)$$

c) $\Delta P_{III} + \Delta P_{II} \leq \Delta P_{shed} < \Delta P_{III} + \Delta P_{II} + \Delta P_I$

In this case the size of over load calculated from the control center is big enough to trip all the loads of class III and II in whole station UFLS control center. In addition for station i it still requires:

$$P_{LDi} = \frac{\Delta P_{shed} - \Delta P_{III} - \Delta P_{II}}{\Delta P_I} P_{Ii} \quad (6)$$

d) $\Delta P_{shed} \geq \Delta P_{III} + \Delta P_{II} + \Delta P_I$

The active power shortage is bigger than the critical value. It is therefore necessary to drop total load that need to shed in whole system to restrain the frequency from sharp decline.

4) Shed the specified load and revise the deviation
All station control centres will shed the specified capacity load as the order sort according to feeder's K_j transferred from the control centre. In order to avoid the shedding deviation due to computational delay, communication delay and other unpredictable events, station control centres will survey the actual shedding load capacity and shed the insufficient load on account of real-time calculations.

MODEL AND ANALYSIS

To examine the performance of the proposed UFLS scheme, the simulated test system with 36 nodes described earlier was analyzed. The traditional UFLS scheme was applied to the system after a generator outage connected to B1 which resulted in an active power shortage of 622.82 MW. The proposed UFLS scheme was applied to the test system. The control centre can calculate the load shedding regional distribution map according to information collected from all station control centres. The boundary values are shown as follows:

$$\Delta P_{III} = \sum_{i=1}^9 P_{III} = 1170.68MW, \Delta P_{II} = \sum_{i=1}^9 P_{II} = 292.68MW$$

$$\Delta P_I = \sum_{i=1}^9 P_I = 124.27MW$$

So: $(\Delta P_{shed} = 622.82MW) < (\Delta P_{III} = 1170.68MW)$

That is only load of class III in this system which need to be shed, and $P_{Ldi} = \Delta P_{shed} P_{III} / \Delta P_{III} = 0.532 P_{III}$, Then get shedding location and capacity as shown in Tab.2.

Conventional UFLS scheme consists of 7 basic rounds and 1 special round as shown in Table 1, and it tripped the top three basic rounds and the special round following the same fault with the proposed scheme. Fig.6 shows the simulated results of the two methods. The generator connected at B1 tripped at 5 seconds in the simulation. The frequency starts dropping and it has been gradually restored to allowable value after down to the lowest point at 49.25Hz for the proposed strategy with broken line. Frequency was recovered to 49.9 Hz after about 10 seconds compared with 20 seconds of conventional method. This confirmed the fast operation of the proposed UFLS scheme. The solid line represents the conventional method. Although it can make the system frequency return to the nominal value, it has three obvious inflection points because it always shed the load one round by one round on account of system frequency and it got no initiative to prevent frequency dropping. This verified the new method has a smoother curve and system frequency has a better behavior.

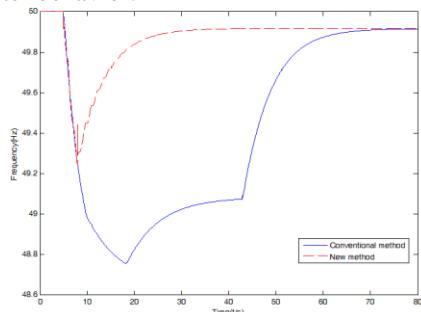

Fig.6 The recovery curve of different shedding methods

CONCLUSIONS

This paper outlines an on-line UFLS scheme to get suitable choice of the shedding load capacity and location

based on information sharing technology in ensuring the system frequency within the permissible range. The scheme has been verified through programming and simulation. By using the proposed technique, UFLS devices can shed load precisely and effectively to prevent system from collapse during large disturbances.

Tab.1 Conventional UFLS scheme

	Setting frequency	Time delay	Shedding capacity
Basic rounds	49.25Hz	0.2s	2.71%
	49.00Hz	0.2s	3.48%
	48.75Hz	0.2s	5.24%
	48.50Hz	0.2s	6.07%
	48.25Hz	0.2s	6.58%
	48.00Hz	0.2s	7.13%
	47.75Hz	0.2s	7.95%
Special rounds	49.25Hz	20s	6.88%

Tab.2 Strategy of the new UFLS scheme

Location	Class III(MW)	Class II(MW)	Class I(MW)	Total (MW)
L1	61.08	0	0	287
L2	90.02	0	0	376
L3	55.58	0	0	226
L4	15.71	0	0	72
L5	18.62	0	0	70
L6	17.39	0	0	86.4
L7	138.32	0	0	500
L8	96.08	0	0	430
L9	130.02	0	0	520

REFERENCES

- [1] Arulampalam A., Saha T.K., 2012, " Fast and adaptive under frequency load shedding and restoration technique using rate of change of frequency ", *Power and Energy society General Meeting*, 1-8.
- [2] Seyedi H., Sanaye-Pasand M., 2009, " New centralized adaptive load-shedding algorithms to mitigate power system blackouts ", *IET proceedings on Generation, Transmission & Distribution*, Vol.3, 99-114.
- [3] El Azab R.M., Eldin E.H.S., Lataire P., 2010, " Optimal location of shedding load at the adaptive UFLS ", *The 2010 IEEE International Energy Conference and Exhibition*, 250-255.
- [4] Omar Y.R., Abidin I.Z., Yusof S., Hashim H., Rashid H.A.A.A., 2010, " Under frequency load shedding: Principles and implementation ", *2010 IEEE International Conference on Power Energy*, 414-419.
- [5] Prabha Kundur, 1994, *Power System Stability and Control*, McGraw-Hill Professional.