

## VACUUM CIRCUIT BREAKERS IN CABLE NETWORKS

Hans SCHELLEKENS

Schneider Electric – France

[hans.schellekens@schneider-electric.com](mailto:hans.schellekens@schneider-electric.com)

Igor SHULEPOV

Schneider Electric - Russia

[igor.shulepov@schneider-electric.com](mailto:igor.shulepov@schneider-electric.com)

Juan TOBIAS

Schneider Electric – France

[juan.tobias@schneider-electric.com](mailto:juan.tobias@schneider-electric.com)

### ABSTRACT

*The impact of switching over-voltages in a public distribution network on cable ageing and the occurrence of earth fault failure are discussed. It is concluded that 95% of the network remains unaffected by the behaviour of the VCB, and that switching over-voltages in the remaining connected Industrial sites don't propagate into the public network. Hence, VCB behaviour cannot explain the increased earth fault failure rate observed in Russia.*

### INTRODUCTION

In Russia the introduction of VCB as an alternative for oil CB's is hindered by an observed increase of cable fault frequency which is alleged to be due to switching over-voltages caused by VCB's. In [1] the author states *"In particular, use of VCB's of certain types in medium voltage networks (especially in city distribution networks), where CLP(=XLPE) insulation cables are used, is unreasonable due to increased insulation degradation of such cables."* This statement contrasts with reality in the rest of the world. Vacuum is today the main interrupting medium in China, USA and West-Europe. In 95% of the applications a VCB can substitute air, oil or SF6 CB without creating undue switching over-voltages. Only for some specific network conditions, special protective measures need to be taken.

The paper addresses the problematic in two separate ways. Firstly, the switching voltages in a public distribution network are evaluated. Secondly, the ageing mechanisms leading to cable failure are correlated with switching over-voltages and cable design.

### PUBLIC DISTRIBUTION NETWORK & SWITCHING OVER-VOLTAGES

Figure 1 shows a typical but simplified public distribution network. The network consists of 5 open rings which are energized by two HV/MV transformers through a main station. The 2 main stations feed 5 open ring networks and are interconnected by a disconnecting circuit breaker. Each open ring consists of 15 ring main units interconnected by 1 km cable. The ring main unit has 2 load break switches and 1 circuit breaker for protection of the MV/LV distribution transformer. Three small and one medium sized industrial network are connected to the public network with respectively 2 or 4 motor feeders and 1 or 2

filter banks. As 84% of the network failures are cable or cable garniture failures [2], their frequency is an important parameter for this study and set at 7 failures/year/100km of cable. Two third of these failures are supposed to be earth fault failures. The network is operated with an isolated neutral. Each function will be briefly discussed with references for more detailed treatment. Table 1 summarizes the main operations and the operation frequency [2,3]; it also gives the probable over-voltages and their duration at both the source and the load side of the network as well as the length of the cable network involved. Discrimination is made between: maintenance, which intervenes in a stable network, and protection, which reacts on sudden unwanted changes.

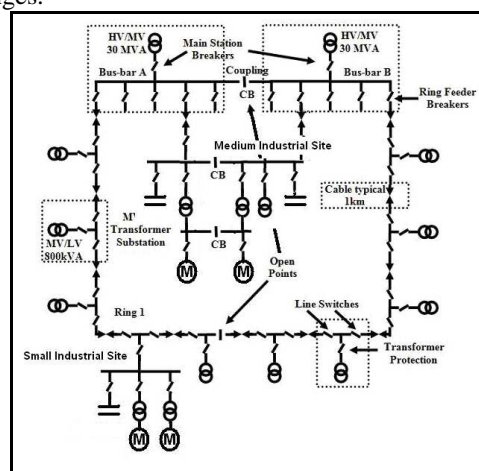

**Figure 1** : Simplified diagram of the public network configuration used in the simulation; characterised with

- 30 MVA / HV-MV main station /  $\cos(\phi)=0.95$
- 5 ring feeders; Each ring 15 km cable and 15 RMU
- 3 Small industrial site (SIS) on ring & 1 Medium industrial site (MIS) with cable to main station

#### Main station

##### Main station breaker

Each station is equipped by a main station breaker which function is to protect against a failure in the station and act as a back-up in case of ring feeder breaker failure

##### Ring Feeder Breaker + Coupling circuit breaker

The ring feeder breakers protect each one end of the ring. Their function is to interrupt the fault current in case of a network failure. They are operated also for preventive maintenance and major network reconfiguration. A coupling circuit breaker disconnects the two main stations; in case of HV/MV transformer failure this breaker can be

closed to rapidly restore the power in the faulty part of the network still providing security.

#### **Maintenance: Load switching.**

De-energising a part of the network by a line feeder breaker is the interruption of the current to the connected MV/LV transformers and the cable of the ring [4]. This operation does not lead to special switching over-voltage.

#### **Protection : Station fault and Line fault**

The MV side of the HV/MV transformer is adequately protected [5]. Although due to the short distance to the HV/MV transformer high short circuit current level and steep rising recovery voltage are to be dealt with, VCB's have more than sufficient dielectric recovery capability.

#### **Ring main unit**

The RMU breaks the ring to create a T-off to a local load most often a MV/LV distribution transformer. As protection of the ring is given by the CB feeder, load break switches are normally sufficient to isolate the RMU from the ring in case of maintenance work either on the RMU or on one of the cable sectors.

#### **Line switch by Load break switch**

The charges manipulated by these Vacuum LBS's during network maintenance include load shedding, breaking the ring current in case of reconfiguration of the ring or breaking of the small capacitive current of a cable sector. One of the LBS's can also be used to create an open point in the ring taking the function of a disconnecter.

#### **Transformer protection by circuit breaker**

The power delivered by the distribution transformer is typically between 100 and 630 kVA. As protective devices for the transformer a combined fuse+LBS or CB are proposed [6]; the latter is here discussed.

#### **Maintenance**

##### **Switching of unloaded transformer**

Opening of the VCB in the steady state means interruption of the magnetisation current of the unloaded transformer. This is a harmless operation due to the high inductivity of the load and the cable capacitance [7].

##### **Switching of loaded transformer**

Switching of the load current produces no over-voltages at current interruption because of the generally high  $\cos(\varphi)$  of the load.

#### **Protection**

##### **Switching of unloaded transformer inrush current**

The current on closing depends on the residual magnetisation or saturation of the transformer core. In the worst case the current can reach peak values of ~12 times the rated current which damps away in typically 200 msec. Although this current in itself represents no problem to the switching device, opening in the first 400 ms should be avoided as due to the very inductive nature of the current substantial over-voltages are produced at the load side [7]. Hence, switching of inrush current occurs only in case of erroneous relay setting. Most manufacturer's integrated protection devices ensure selectivity with any low voltage

fuses and avoid erroneous opening [6]. So no surge protection is needed. Manual operated LBS's have a mechanism that exclude a fast close-open sequence.

#### **Transformer-secondary fault**

The value of the current is determined by the short circuit impedance of the transformer. Due to the relatively low capacitance of transformer and cable connection the recovery voltage rises steeply. Using a VCB the interruption of the inductive current can create multiple restrikes with over-voltages up to 5pu., virtual current chopping is unlikely due to the relatively high current values >800 A for 100kVA and above. Often a trade-off between risk and cost will not favour the use of surge arrestors.

#### **Transformer fault**

A transformer fault currents range from earth fault to full 3 phase short circuit without specific over-voltages.

#### **Small and Medium industrial site**

Practice differs between the public network and the industrial site mainly in the switching frequency of the switchgear and in the extended use of reactive power consumed by motors, which are compensated by capacitor banks. **Motor switching** using a circuit breaker brings the risk to open the circuit occasionally in the starting phase. Protective measures might be required [4] to reduce the switching voltages. The level of achievable protection is 3pu. for networks with fast earth fault clearance or otherwise 5pu. After **switching the capacitor bank** off the bank is left with a dc voltage that stresses the VCB. As a precaution protection against restrikes [10] is proposed for frequently operated banks. Other switching duties are detailed under RMU as for transformer protection; special attention for **inductively loaded transformers** as the high switching frequency imposes adequate protection.

#### **Voltage propagation in the network**

Table 1 shows that switching inductive and capacitive loads give higher switching over-voltages at the load side. When the VCB breaks down this voltage will unavoidably propagate into the upstream cable network. This propagation is governed by the line impedance  $Z_L$ ; at each junction with  $n$  incoming lines, all with  $Z_L$ , the ratio between transmitted  $U_T$  and incoming  $U_I$  voltage amplitude obeys to:  $U_T/U_I = Z_L / (n * Z_L)$  taking the reflected part in account. For a Main station and RMU this ratio becomes respectively 20% and 33%; for SIS and MIS this ratio can be smaller when the capacitor bank is coupled to the bus bar as its impedance is much smaller than  $Z_L$ . Because of this phenomenon load-side over-voltages cannot mitigate in the cable network.

#### **CABLE FAILURE & SWITCHING VOLTAGES**

Today cable failures are attributed mainly to water treeing or electrical treeing. **Water treeing** [8] depends strongly on the chemical reaction under alternating polarization and

Table 1: Network components and switching characteristics like frequency, over-voltage value and duration.

number stations	number units	Function	Type of Operation	maintenance	protection	Switching Frequency [1/year]	duration [s]	Switching Over-voltage [pu]		Cable length [km]		
								Source Side	Load Side	Source Side	Load Side	
2	Main station	1	MSB	fault		x	0.03	0.005	2	0	0.1	37.5
		5	RFB	fault 3□		x	0.18	0.005	2	0	30	7.5
		1	CCB	Earth fault		x	0.35	7200	1.73	1.73		
75	Ring Main Unit	2	LBS	Cable sector	x		0.20	60	1	1.5	37.5	0.02
		1	CB	unloaded T	x		0.01	0.005	1	2.2		
				loaded T	x		0.20	0.005	1	0.3		
				unloaded T inrush	x		0.00	0.005	1	8.5		
				T sec fault	x		0.30	0.005	1.4	5		
				T fault		x	0.03	0.005	2	0		
3	Small Industrial Site	1	CB	Fault		x	0.03	0.005	2	0	37.5	0.1
		2	CB	Motor Load	x		1000	0.005	1	1		
				Motor Start	x		10	0.005	1	5		
				Fault		x	0.06	0.005	2	0		
		1	CB	Capa Load	x		500	60	1	1.5		
				Capa + restrike	x		5	60	1	3.3		
		Fault		x	0.06	0.005	2	0				
1	Medium Industrial Site	1	CB	Fault		x	0.03	0.005	2	0	37.5	0.1
		4	CB	Motor Load	x		1000	0.005	1	1		
				Motor Start	x		10	0.005	1	5		
				Fault		x	0.06	0.005	2	0		
		2	CB	Capa Load	x		500	60	1	1.5		
				Capa + restrike	x		5	60	1	3.3		
				Fault		x	0.06	0.005	2	0		

depolarization of water with the XLPE and weakly on the electrical field. The frequency of switching does not match with the elevated number of cycles required to produce failure. So this process is excluded. **Electrical treeing** [9] is a process that depends strongly on electric field only. Experimental work shows a linear relationship between the cable life time, log(t), and the electrical field, E, called Crine model. Figure 2 shows the cable life time curve with respect to electrical stresses.

**Cable stresses not induced by switching**

Through the XLPE cable standard VDE 0276-620 the cable design for a fixed nominal voltage is intimately coupled to the electrical field. Two characteristic working points of the XLPE cable for a 10 kV network are given:

- the 30 year operating point, and
- the mandatory 4 hours test at 4 times U<sub>0</sub>.

Earth faults together with the network philosophy of an isolated neutral are another major stress for the cable. The 2 hours clearing time cumulates to total stress duration of 200 hours at 1.73pu. in 30 years.

**Public network cable stresses: 95% of network**

Interruption of 3 phase faults generates over-voltages of typically 2pu. Their individual short duration of 5msec. cumulates to total stress duration of about 1s. in 30 years.

**Load side cable stresses: 5% of network**

As table 1 shows, switching over-voltages go up to 5pu. at the load side; the total cable length of affected loads represents 3 – 5 % of all installed cables. Depending on the

load the individual cable stress is either:

- RMU transformer: the very low switching frequency of secondary earth faults cumulates to total stress of 5 pu. with duration of about 10millisec. in 30years.
- Capacitor bank : frequent switching and long duration of over-voltage cumulates to total stress duration of about 500 hours in 30years. Over-voltages due to rare restrikes are limited to 3.2pu. with cumulated duration of 30 min [10].
- Starting Motor: by the occasional switching of motors in the starting phase, over-voltages are limited to 5pu. with cumulated duration of 3sec.

**DISCUSSION**

95% of the public network is not affected by switching over-voltages exceeding 2pu. due to fault clearing. Earth faults are the principal source of cable stress due to their repetitive nature and long duration. The remaining 5% of the network is affected by over-voltages due to inductive load switching. Based on risk assessment, protection is proposed when over-voltages can exceed 5pu. Effective protection below 5pu. is not possible in isolated neutral networks with a clearing time of 2hours.

It is outlined that the over-voltage in a load cannot propagate without damping into the upstream network. Therefore it is impossible that over-voltages due to inductive load switching deteriorate the dielectric insulation of the cables and by this increase the earth fault failure rate in a public network.

Figure 2 is based on the assumption that the cable is dimensioned according VDE. The dielectric cable stresses are lower, by a safety margin of 10 to 20, than those affecting the cable life time [9]. VDE prescribes XLPE thickness of larger than 3.5mm for 10kV and special semiconductor screening. In case of reduced isolation thickness and or absence of these semiconductor screens, dielectric stresses increase, the safety margin reduces and the earth fault failure rate increases.

Based on the above discussion, the increased earth fault failure rate observed in Russia in public networks cannot be attributed to switching over-voltages caused by vacuum circuit breakers.

## CONCLUSION

Vacuum Circuit Breaker operations cannot explain the increased failure rate in Russian cable networks as :

- VCB Switching operations don't influence the cable life time in 95% of the public distribution network.
  - Switching surges in connected Industrial sites don't propagate into the public network and are of no concern.
- The outcome of this study confirms current practice in Europe and North America.

## REFERENCES

- [1] L.I.Sarin "Vacuum circuit breakers in distribution networks. Mechanical characteristics and overvoltages during switching/ Principles of design, development and operation of urban distribution networks, 2010, *Proc. of the 17th extending session of the Association of Russian power supply 'Progressselektro'*, S.Petersburg, pp. 56-62,

- [2] R.J.R.Waumans, 2000, "Reliability of the Electricity Supply in the Netherlands", *Distribution 2000 Conference*, Australia,
- [3] H.Schellekens, 2010, "Impact of Vacuum Switch-disconnectors on Reliability of MV distribution networks", *China International Conference on Electricity Distribution*, China
- [4] A.Mueller, 2011, "Switching Phenomena in Medium Voltage Systems Good engineering Practice on the Application of VCB's and Contactors", *Petroleum and Chemical Industry Conference Europe*
- [5] A.M.Chaly, 2006, "Relevancy of IEC Requirements Related to Switching Cable and Line Charging Currents for Medium Voltage Vacuum Circuit Breakers (VCB)", *XXIInd Int. Symp. on Discharges and Electrical Insulation in Vacuum*, Matsue
- [6] D.Fulchiron, "Protection of MV/LV substation Transformers, 1998, Cahier technique n°192, Schneider Electric, Grenoble, France
- [7] M.Popov, "Investigation of the circuit breaker reignition overvoltages caused by no-load transformer switching surges" *European Transactions on Electrical Power*, Vol. 11, Issue 6, pp.413-422, 2001
- [8] G. Chen, 2009, "Electrical Treeing Characteristics in XLPE Power Cable Insulation in Frequency Range between 20 and 500 Hz", *IEEE Transactions on Dielectrics and Electrical Insulation*, Vol. 16, No. 1, pp. 179-188
- [9] B.Marungsri, "Investigation Life Time Model of 22kV XLPE Cable for Distribution System Applications in Thailand", *WSEAS TRANSACTIONS on SYSTEMS*, n°7, Vol.10, July 2011, pp. 226-238
- [10] H.Schellekens, 2008, "Capacitor Bank Switching with Vacuum Circuit Breakers", *China International Conference on Electricity Distribution*, Guangzhou

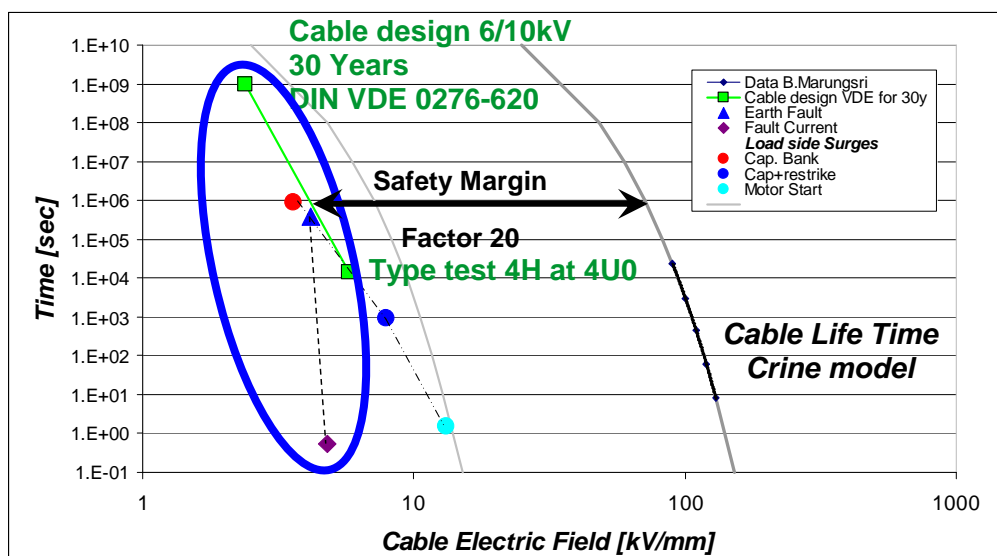

**Figure 2 :** Diagram combining the electrical treeing life time limiting curve for XLPE cable and electrical stresses generated in a public distribution network; cables designed according VDE 0276-620; ellipsoid indicates the cable stresses for a public distribution network with isolated neutral ; points beyond the ellipsoid are for specific loads.