

DGDEMONET: IMPACT OF VOLT/VAR CONTROL ON INCREASING THE VOLTAGE BAND RESERVE – RESULTS FROM FIELD TRIAL VALIDATIONS

Roman SCHWALBE
AIT - Austria
roman.schwalbe@ait.ac.at

Matthias STIFTER
AIT - Austria
matthias.stifter@ait.ac.at

Benoit BLETTERIE
AIT - Austria
benoit.bletterie@ait.ac.at

Andreas ABART
Energie AG Oberösterreich Netz GmbH
andreas.abart@netzgmbh.at

Rudolf POINTER
Salzburg Netz GmbH
rudolf.pointner@salzburgnetz.at

Frank HERB
Vorarlberger Energienetze GmbH
frank.herb@vorarlbergnetz.at

ABSTRACT

In the DG DemoNet Validation project a coordinated voltage controller was developed to actively integrate a high share of renewables into existing distribution systems. The impact of controlling the medium voltage transformer and the reactive power of distributed generation - based on the actual voltages of critical nodes - on voltage range and number of tap changer operations is analysed. Evaluation is based on records gained in two distribution systems where coordinated voltage control is operated for more than half a year.

INTRODUCTION

Integrating a high amount of Distributed Generation (DG) into existing medium voltage (MV) grids can cause unacceptable voltage rise in times of high generation especially in rural networks. Grid enforcement is a comparably expensive solution which makes the integration of DG often uneconomical [1]. Active power curtailment is not desirable and should be minimized especially for renewable DG.

Coordinated voltage control by utilizing the HV/MV transformer's tap changer and the capability of DGs to generate or consume reactive power can significantly increase the number of DGs which can be hosted in MV grids, without getting into voltage violations. Based on actual voltage measurements at critical grid nodes (CN) together with the measurement of the actual active and reactive power of all controllable DGs, voltage set values for the transformer's Automated Voltage Controller (AVC) and reactive power set values for the DGs can be periodically calculated and set. This keeps all grid voltages within the allowed voltage limits, avoiding active power curtailment. PLC and radio link systems enable communication between the centrally operated voltage control unit and DGs via tele-control protocol.

Previous Work

The first developed and later improved control algorithm can be found in [2]. Details about validating the controller by hardware-in-the loop simulation are in [3]. Issues related to the deployment of the controller in the field and a listing of projects relating to coordinated voltage control can be found in [4].

CONTROL STRATEGY

In the DG DemoNet Validation project the coordinated voltage controller Central Voltage Control Unit (CVCU) was developed. This controller splits the task of voltage control into two controllers which can work independently from each other [5]: The *Level Control* calculates the voltage set values for the transformer's (TF) AVC following different modes ('upper-limit', 'centered', 'lower-limit', 'minimum-tapping') and the *Range Control* calculates the reactive power set values for the DGs, based on the contribution matrix approach (Fig. 1).

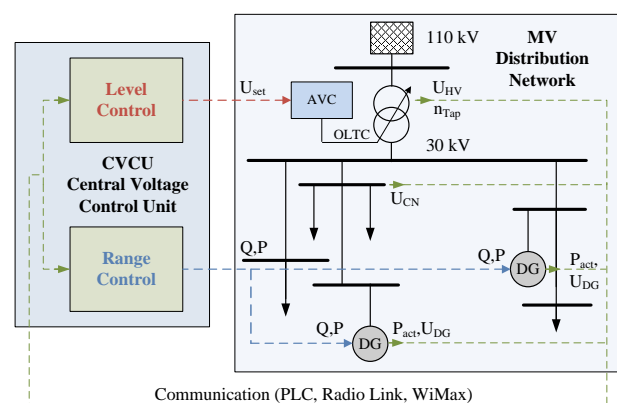

Fig. 1: Schematic functional diagram of the CVCU

FIELD TRIALS

The coordinated voltage control field trials are carried out in two Austrian distribution grid substations: "UW Lungau" in Salzburg and "UW Nenzing" in Vorarlberg, which are described in [5] in detail. Both grids are operated alternatively CVCU controlled and conventionally controlled. Conventional control means to operate the DGs at $\cos\phi=1$, and the TF in local voltage control: "UW Nenzing" only controls local busbar voltage, while at "UW Lungau" line drop compensation is used.

In both grids the DGs capability to contribute reactive power is less than planned due to several reasons that can be summarized in:

- Technical difficulties to adapt excitation controller

- of existing DGs – especially for older units
- Some of the existing DGs can hardly provide any reactive power when operated with rated power, because they were not sized for it (apparent power limitation)

Because the DGs contribution to voltage control in the field trial is smaller than planned, the validation strategy has to be adapted.

VALIDATION APPROACH

The voltage control approach will be validated by comparing the operation of the conventionally controlled network (operated without coordinated voltage control) with the CVCU-controlled network, according to two different criteria:

- Ability to keep all grid voltages between the given voltage limits.
- Reduction of the voltage range which can be used for additional DG integration.

While the first aspect can be validated easily by evaluating the grid measurement data, the second aspect is more difficult to evaluate: Either the voltage situation in the CVCU controlled state or in the conventionally controlled can be measured – so no direct comparison is available (operation windows might not be fully comparable).

Experiences from field trials showed that dynamics in voltage variations due to changes of load and generation (long-term) and measurement value fluctuations (short-term) are in the same order of magnitude and even higher as the voltage variation caused by the controllable DGs for the reason previously mentioned. Therefore voltage range comparison on a week-to-week base as well as on a day-to-day-base might take long periods of operation. To get a quick overview about performance of the applied control during the validation period it is planned to switch on and off *Range Control* in an interval of 20 minutes and compare on a 10min power quality interval basis (according to IEC 61000-4-30).

To maximise the impact of the alternating operation it is planned to change the objective function that minimises the reactive power demand of the DGs to bring grid voltages into the effective voltage band (described in [4]). The new objective function minimises the voltage range regardless of the available effective voltage band: Minimize (1) with (2) under the consideration of the constraints (3).

$$\min_{\Delta Q_{DG}} \left(\max(U_{CN}^{new}) - \min(U_{CN}^{new}) \right) \quad (1)$$

$$U_{CN}^{new} = U_{CN} + A_{CN,DG}^Q \cdot \Delta Q_{DG} \quad (2)$$

$$Q_{DG}^{\min}(P_{DG}) \leq Q_{DG} + \Delta Q_{DG} \leq Q_{DG}^{\max}(P_{DG}) \quad (3)$$

U_{CN} are the actual voltage measurements from the grid, and U_{CN}^{new} are the voltages that will occur in the grid according to the reactive power contribution matrix $A_{CN,DG}^Q$ when the DGs put the changes of reactive power ΔQ_{DG} into practice. The reactive power provided by DGs after the changes are implemented $Q_{DG} + \Delta Q_{DG}$ has to be within the valid and

stable operational area of each generators PQ diagram, so reactive power limits $Q_{DG}^{\max}(P_{DG})$ and $Q_{DG}^{\min}(P_{DG})$ which depend on the actual DGs active power P_{DG} have to be considered.

Alternating this control strategy with operating DGs at $\cos\phi=1$ will enable validation methods to get a significant result of the reduction of voltage range when applying coordinated voltage control (despite the lack of controllable reactive power). This objective function will increase the reactive power that has to be provided by the DGs as opposed to the optimised control strategy stated in [4].

RESULTS

The intermediate results shown below are evaluated since the start of the validation period until end of 2012 and contain 10 CVCU-controlled weeks in “UW Lungau” (every third week beginning in June 2012) and 21 CVCU-controlled weeks in “UW Nenzing” (almost every week starting in May 2012). Final results will be available after the end of the validation period in summer 2013.

All results discussed in this chapter are based on manually reviewed data of one-minute average values, where untypical grid situations were filtered out which would have influenced the validity of the results. The most noteworthy time periods excluded from validation were two situations, where the CVCU performed wrong due to faulty topology and grid information (several hours in “UW Lungau” and around one day in “UW Nenzing”). Beside these two situations, where CVCU operation was stopped by the operating staff (the grid operation could be continued without incidents), short term interrupts of communication where filtered out, where grid operation was not affected. The measurement values are plotted as duration curves. Thus the total time fraction of an observation period where a measurement is smaller or greater than a specific value can be directly read from the diagram with the drawback that dynamic information is lost.

Substation “UW Lungau”

Fig. 2 and Fig. 3 show the duration curves of voltage measurements for all installed CNs that are supplied by “UW Lungau” in normal switching state. Fig. 2 shows the aggregation of all conventionally operated time periods, where the used voltage range (defined as the difference between absolute maximal voltage and the absolute minimal voltage that occurred any time during the comparison period) is 0.0553 p.u. Fig. 3 shows the aggregation of all CVCU-controlled time periods, where the used voltage range is 0.0564 p.u. It can be clearly seen that line-drop-compensation operates the grid around 0.01p.u. above the voltage limits set for CVCU operation, but the used voltage range increased during the CVCU-controlled comparison period. This is because the CVCU was set to operate in *Level Control* mode ‘*minimum-tapping*’, so the given voltage band 0.99 to 1.05 p.u. was fully utilised, and tap

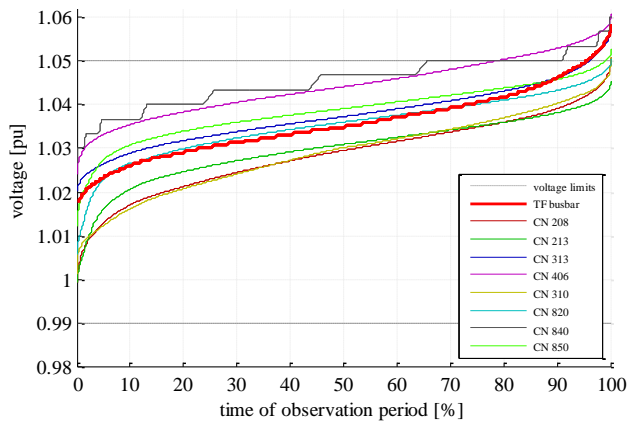

Fig. 2: Duration curves of CN voltage measurements in "UW Lungau" during 72 conventionally controlled days

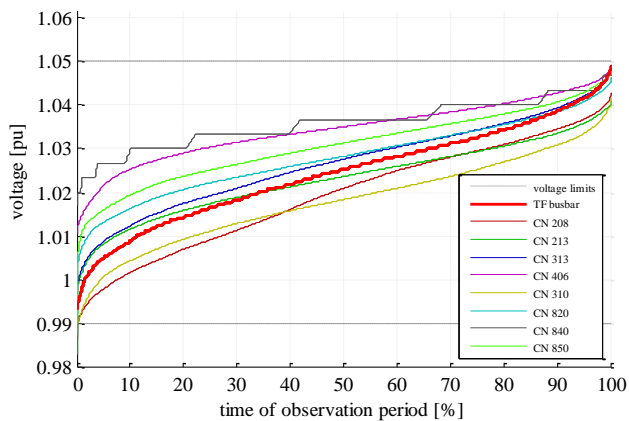

Fig. 3: Duration curves of CN voltage measurements in "UW Lungau" during 66 CVCU-controlled days with Level Control mode 'minimum-tapping'

changes where only performed to avoid voltage violations. This reduced the number of necessary tap-changes by about 26%. Note the discrete steps in the duration curve of the CN 840 (grey stepped curve), caused by different thresholds for sending measurement updates of the voltage measurement devices.

Fig. 4 shows a direct comparison of the voltage range in CVCU controlled and conventionally controlled grid states. Despite the *Range Control* was active, the direct comparison without consideration of additional environmental influences shows that the voltage range increased in the CVCU controlled periods compared to the conventionally controlled periods, at higher ranges (0.025 – 0.05 p.u.).

An important parameter that has to be considered to accomplish a meaningful comparison is the grid's switching state. In "UW Lungau" a ring switching state exists, which significantly reduces the voltage range as shown in Fig. 5. Two adjacent weeks of CVCU/conventionally controlled grid operation where analysed respectively for normal and ring switching state. These results look promising and more realistic, since the compared weeks are consecutive. But it must be noted that even in consecutive weeks the load and

generation situation can significantly change, making a week-to-week comparison error-prone.

Since the grid operation shall not be interfered by the validation, grid topology is determined by the control room, and the validation has to cope with changing topologies. Therefore the comparison of voltage ranges as it was done in Fig. 4 is not appropriate because other environmental parameters have to be considered in the comparison as it was done in Fig. 5.

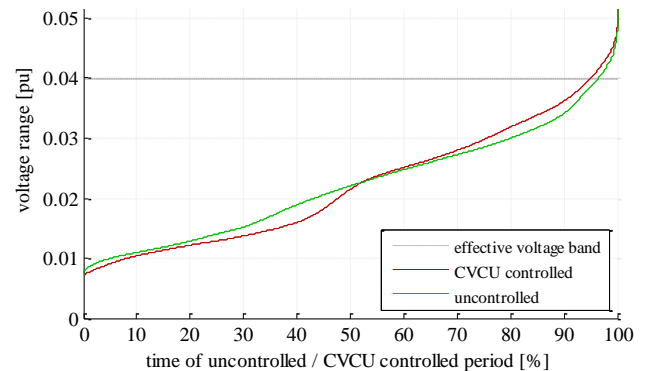

Fig. 4: Comparison of CN voltage range in "UW Lungau" during 72 conventionally controlled days and 66 CVCU-controlled days

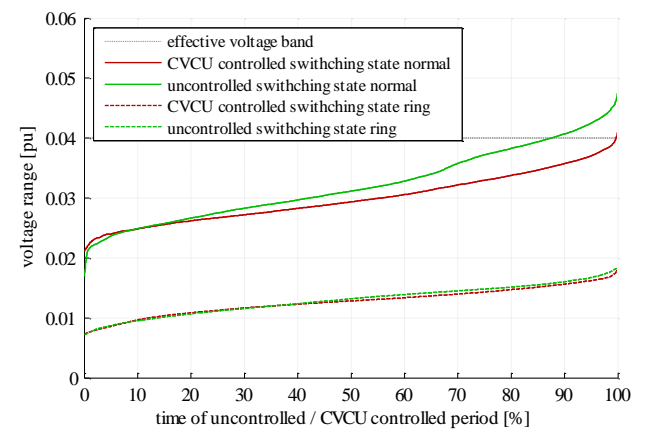

Fig. 5: Dependency of voltage range on topology in "UW Lungau": all four curves show one week, weeks with the same switching state area adjacent

Substation "UW Nenzing"

Fig. 6, Fig. 7 and Fig. 8 show voltage measurement duration curves for one week each, with three consecutive weeks with similar generation situations. In the conventionally controlled case in Fig. 6 the used voltage band is 0.0358 p.u., which is higher than in Fig. 7 with 0.0285 p.u. where the CVCU was set to operate in *Level Control* mode 'upper-limit' and higher than in Fig. 8 with 0.0308 p.u. where it was set to 'centered'. For this comparison, *Range Control* was switched off, so CVCU was simply operated as a distributed voltage controller.

As the *Level Control* mode was not set to 'minimum-tapping', the CVCUs priority is to maintain voltage quality,

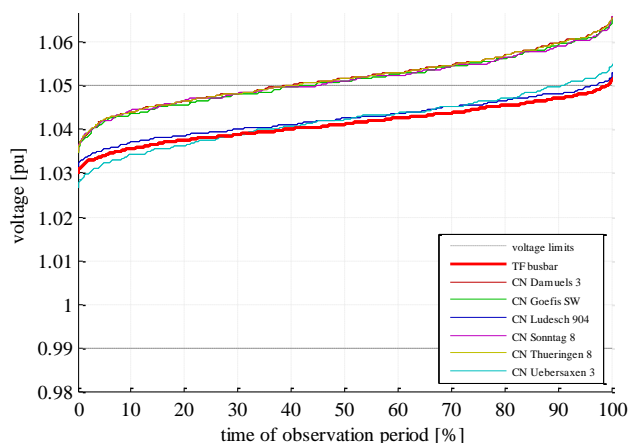

Fig. 6: Duration curves of CN voltage measurements in "UW Nenzing" during 7 conventionally controlled days

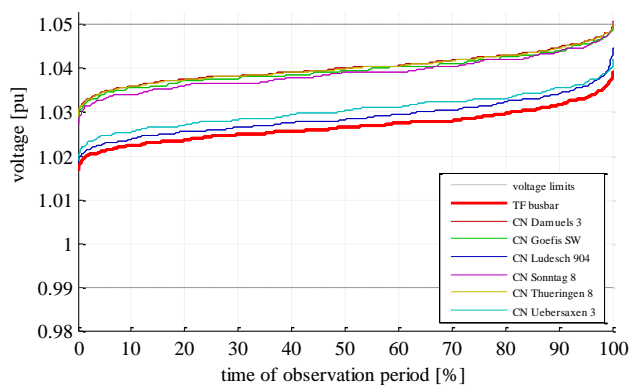

Fig. 7: CN voltages in "UW Nenzing" during 7 CVCU-controlled days with Level Control mode 'upper-limit'

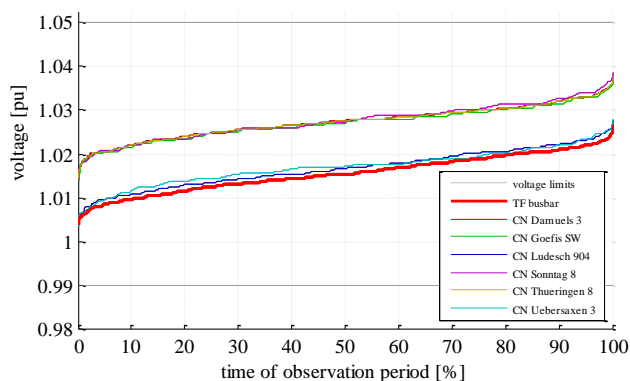

Fig. 8: CN voltages in "UW Nenzing" during 7 CVCU-controlled days with Level Control mode 'centered'

so the number of needed tap-changes increased by 37% in 'upper-limit' and by 59% in 'centered'.

While the 26% decrease in tap-changes with 'minimum-tapping' in "UW Lungau" was evaluated based on the whole validation period (making this result very reliable), the increases of tap-changes in "UW Nenzing" were calculated based on the three one-week-periods displayed above. Nevertheless the above evaluation is a strong indication that other *Level Control* modes than 'minimum-

tapping' increase the amount of tap-changes while decrease of voltage range (increase in available voltage band) can be expected.

CONCLUSION

The analysis of the impact of coordinated voltage control strategies on the voltage range is complex due to the dependency of several parameters

- Network switching state
- Load variation (e.g. daytime, temperature, season)
- Generation variation (e.g. weather)

To demonstrate the ability to reduce the needed voltage range when applying coordinated voltage control concepts, the *Range Control* strategy of the CVCU developed in the DG DemoNet project was adapted to maximise the available voltage band for additional DGs.

The intermediate results from field trials in two Austrian distribution grids show, that following a 'minimum-tapping' strategy inside the given voltage limits saves 26% of necessary tap-changes. On the other hand, operating the CVCU in a distributed voltage control mode placing the voltage range 'centered' or 'upper-limit' within the given voltage limits needs approximately 50% more tap-changes, but a gain in voltage band can be achieved even without utilization of DGs.

OUTLOOK

Validation of gain in voltage band will be accomplished with calibrated power quality measurement devices over the next snow melting season and results will be published.

REFERENCES

- [1] W. Prügler, F. Kupzog, B. Bletterie, und B. Helfried, „Active grid integration of distributed generation utilizing existing infrastructure more efficiently - an Austrian case study“, in *Electricity Market, 2008. 5th International Conference on European*, 2008, S. 1-6.
- [2] A. Viehweider, B. Bletterie, D. B. de Castro, und H. Brunner, „Advanced coordinated voltage control strategies for active distribution network operation“, in *Electricity Distribution - Part 2, 2009. CIRED 2009*.
- [3] F. Andren, S. Henein, und M. Stifter, „Development and validation of a coordinated voltage controller using real-time simulation“, in *IECON 2011 - 37th Annual Conference on IEEE Industrial Electronics Society*, 2011, S. 3713–3718.
- [4] M. Stifter et al, 2011, "DG DemoNet Validation: Voltage Control from Simulation to Field Test", *IEEE Innovative Smart Grids Technologies Europe 2011*, Manchester, 2011
- [5] M. Stifter et al, 2012, "DG DemoNet: Experiences from Volt/VAr Control Field Trials and Control Algorithm Advancements", *IEEE Innovative Smart Grids Technologies Europe 2012*, Berlin, 2012