

SCHEMA PROJECT–INNOVATIVE CRITERIA FOR MANAGEMENT AND OPERATION OF A CLOSED RING MV NETWORK

Simone BOTTON
Enel Distribuzione – Italy
simone.botton@enel.com

Luca CAVALLETTO
Enel Distribuzione – Italy
luca.cavalletto@enel.com

Federico MARMEGGI
Enel Distribuzione – Italy
federico.marmeggi@enel.com

ABSTRACT

In this paper is presented an innovative project that experiment, in a real MV distribution grid, a closed ring network operation by adopting an advanced control system that will be realized through:

- use of sensors and fault detectors along the relevant points of the network;
- use of circuit breakers instead of disconnectors in MV-LV substations;
- a communication infrastructure based on optic fibres combined with MV overhead cables.

In particular, in this paper are shown the main operating criteria and the technical solutions developed by Enel Distribuzione that will be applied to an existing network and also in the POI P4 project (closed ring MV network operation in order to increase network hosting capacity for the connections of new DGs).

The project is being funded by the Italian Ministry of Economical Development, within an Innovation Program carried out in 4 Regions of the South of Italy in the frame of the Programma Operativo Interregionale (POI) "Energie Rinnovabili e Risparmio Energetico".

INTRODUCTION

ScheMa is a three-year project, which began in September 2011 and it is expected to end in August 2014, which proposes to test the performance of MV network portions in closed ring operation, using an innovative control and fault detection system, through the use of appropriate sensors and fault detectors to be installed at the main nodes of the network and the laying along the MV line of optic fiber for transmission of data.

The MV network to be tested will be a portion of the existing operating network situated in an area of low / medium concentration of customers and will consist of a lobe connected to the same busbar of a primary substation. This scheme is the basic element for any subsequent project development on a wider scale.

Main benefits awaited for the electrical system users

The main results and benefits that the project aims to achieve are:

- availability of a MV network with high reliability, extremely resistant to atmospheric disturbances and

- low environmental impact (less electromagnetic pollution and reduced need for cutting plants);
- advanced network control, with real-time monitoring of various electrical parameters and the possibility of seamless data exchange between customers, producers, DSOs and consequent automatic adaptation of the network configurations;
- reduction of power losses;
- selection of faulted branches with minimal impact on customers;
- an increase in short-circuit power and higher availability to the insertion of distributed generation.

SCHE.MA. PROJECT

Planned activities and resources involved in the project

Following are the planned activities for the experimental project:

1. theoretical study of functioning models of the MV network for the development of innovative methods of operation and protection of a closed ring MV network (connected to a single MV busbar) in meshed configuration;
2. drafting of technical specification for the realization of an overhead MV cable with included optic fiber, to be used in the remaking of existing MV lines with the possibility to re-use existing pillars;
3. drafting of technical specifications for the creation of prototypes for the detection of electrical parameters and faults, as well as interface equipment between optic fiber and these detection devices / protection to be installed in the secondary substations;
4. choice of devices for switching and selection of faults;
5. drafting of technical specifications for the realization of a prototype of a MV protection device that uses the data coming from sensors and fault detectors installed along the MV line via optic fiber and processes them both in case of earth fault or short circuit, minimizing the length of the network branch that will be taken out of service;
6. design and construction of a pilot plant that is part of an existing MV network;
7. experimental pilot plant operating in closed ring and analysis of its behavior;
8. study of operating data and development of criteria

for the operation and protection in order to extend this experience even on a network related to busbars in different primary substations.

The project activities will be performed by ENEL Distribuzione, which will also develop and acquire outside the prototypes of the equipment provided by the project, which will be used for the realization of the pilot plant.

Currently (end of 2012) has been completed the design phase of the pilot plant: during 2013 the building phase will be completed .

Structure of the project

The Project has been subdivided into 8 Work Packages:

WP1: Operational Criteria

WP2: Technical Specifications of Cable and Optic Fibre

WP3: Sensors and Circuit breakers

WP4: Communication Infrastructure

WP5: Protection System

WP6: Design and realization of the experimental network

WP7: Pilot test

WP8: Innovative operational criteria.

DESCRIPTION OF THE SELECTED SITE

In order to properly test the functioning and the expected benefits from the project, it was chosen a network (two MV lines) in which:

- the annual failure rate of transient interruption exceeds 50 in at least one of the last four years;
- the length of both lines is longer than 60 km;
- the percentage of the overhead line is greater than 90% of the total extension of the line;
- the percentage of existing overhead cable is less than 25% of the total extension of the line;
- there is the possibility for the two lines to be closed through an existing secondary substation without the need to build new substations (in order to use as much as possible an existing network and to minimize the environmental impact);

in accordance with the following technical constraints:

- voltage drops not exceeding 10% in every node of the network;
- after a fault in any of the network branches, the remaining healthy branches must be capable of feeding all the loads;
- i^2t level must be acceptable in the MV lines.

The trial will take place in the Province of La Spezia in the Liguria region (Italy), in an area predominantly mountainous. Chosen MV lines are named "CARRODANO" and "VARESE", respectively 78.14 and 90.45 km long, from Primary Substation "VIZZA", which is currently operated with joint MV busbars and compensated neutral.

Results of load-flow calculations on the existing network proved the technical feasibility of the closed-loop

configuration through the upgrade of only 7 km of overhead lines. On the other hand, the results showed improvements in terms of voltage level along all the network and higher values of short circuit power on all the node with respect to the same network in radial configuration.

CHARACTERISTICS OF THE PROJECTED SYSTEM

Devices

Each relevant node has been equipped by an "Intelligent Ethernet switch" that allows communication between the MV/LV substation and the adjacent ones. These switches allow a very fast transmission of a signal coming from two digital inputs.

In order to detect a electrical fault, each node has been equipped by an advanced Fault Passage Indicator (called RGDM). These FPIs are able to detect any type of electrical fault including directional phase-to-ground fault and directional phase-to-phase fault.

In order to collect the measurements from MV nodes, existing cable terminations have been replaced by an innovative "sensorized" termination, consisting in a termination for air connection with pre-calibrated high accuracy current and voltage passive sensors embedded.

In order to select each type of fault in a very short time, traditional disconnectors have been replaced by innovative vacuum circuit breakers for MV/LV substations (DY900).

Fault Selection System

The Fault Selection System is based on three independent selection levels.

The first level (see [2] for a detailed description) adopts a typical Permissive Overreach technique between two facing nodes. In case an electrical fault occurs on a ring's branch, each FPI will start and send, via switch, an enable signal to the directly facing FPI. If the FPI that receives the enable signal is itself started, then the opening of the circuit breaker node will be commanded.

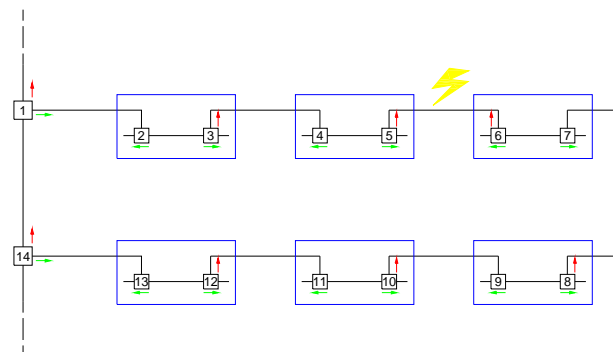

Figure 1. Fault Selection by means of PO automation.

The second selection level, called back-up first level (BFL), is based on a centralized logic, ensured by the Primary Substation Remote Terminal Unit (RTU). In fact

the RTU collects the start signals coming from each FPI and, with a chronometric logic selection, it is possible to properly open the selected circuit breakers for a correct fault selection.

The third level, called back-up second level (BSL), is based on the protections installed on the Primary Substation feeders. Through a appropriate setting of the protection devices installed in the Primary Substation (nodes 1 and 14 in Figure 1) a second level of back-up is ensured. BSL must be set with a delay time longer than that of BFL, per each threshold of protection system.

The closed ring network made from the existing "Carrodano" and "Varese" MV lines is represented in Figure 2, in which the substations where the FPIs will be installed are highlighted in yellow.

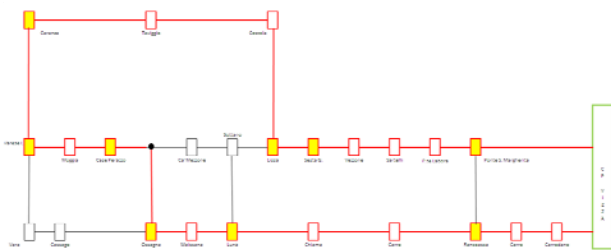

Figure 2. structure of the test network.

Communication System

In order to reduce as much as possible communication times between the devices installed in automated secondary substations and in primary substation, these will be linked with an optic fiber to be installed along the MV lines.

Due to the different types of overhead conductors on the existing network, it is needed to adopt various and alternative installation solutions allowing, among other things, the experimentation of different technologies of optic cables.

Different designs ensure that the solutions will substantially cover all of the types of MV network throughout the country and that they can be reproduced in geographical areas with different characteristics and territorial constraints.

Installations on underground network

In such sections will be laid an optic cable in special ducts adjacent to the existing MV cable, for a total of 4.56 kilometers.

Installations on overhead network

In the network branches with overhead cables, will be installed the ADSS optic cable using existing supports, for a total of about 17 km.

In the overhead branches with bare aluminum-steelconductor cross section of 150 mm², it was chosen to

replace the conductor with another one having built-in optic fiber. This solution allows the testing of a new type of conductor, called OPPC (Optic Phase Conductor), for which the installation on existing MV lines consists in replacing one of the three phases. This technology will be used for 14.1 km.

In portions of the network with bare copper conductor with cross section of 70 mm², was chosen to wrap the optic fiber around the existing conductor. The innovative technology experienced in this solution, called Phase Wrap, consists of a dielectric optic cable which exploits the mechanical resistance of the conductor around which is wound and will be used for 12.8 km.

In the remaining 4 km of overhead network with bare conductor in copper or aluminum of different section, it was decided to rebuild the whole line by replacing the bare conductors with an overhead cable with integrated optic fibers.

EXPECTED RESULTS

The following example compares the different behaviors of the MV network in the case that the secondary substations are equipped with classic automation (FNC / FRG logics in radial configuration) or the Permissive Overreach automation in closed-loop configuration used in the Sche.Ma project (Sche.Ma automation).

A fault on the i-th branch of a line divided into four automated sections involves, in the case of classical automation:

- FNC logic, a long interruption duration per customer underlying the faulted branch and sections downstream of the latter (customers electrically farthest from the primary substation);
- FRG logic, a short interruption for customers underlying the healthy branches and a long interruption for customers underlying the faulted branch and sections downstream of the latter.

With Sche.Ma automation, a fault inside the i-th automated branch operated in closed loop (meshed configuration) involves a long interruption only for customers underlying the faulted branch.

In the hypothesis of a fault in the first branch of the line, with classical automation the customers affected by the fault, highlighted in red, correspond to the customers underlying the entire line (Figure 3).

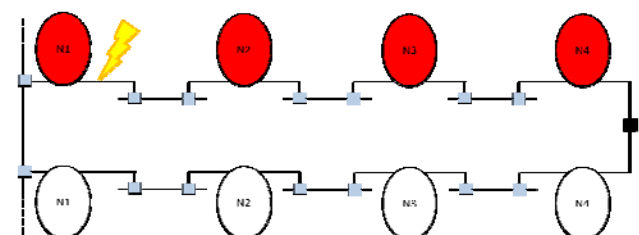

Figure 3. Unsupplied customers in the case of classical automated fault detection system.

Considering the same lines in closed-loop configuration, after the same fault, it is observed that customers who perceive the interruption, always highlighted in red, now correspond to customers between two automated nodes. (Figure 4):

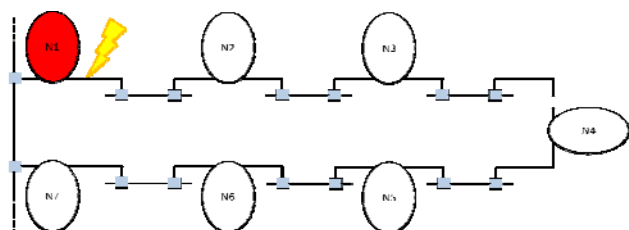

Figure 4. Unsupplied customers in the case if Sche.Ma automated fault detection system

It should, however, be emphasized that the above examples represent the worst case of a fault on a line radially operated and that the difference of customers interrupted between the two network configurations in this case is not to be considered a general rule. Anyway, the example clearly highlights the potential improvement in the continuity of supply that can be obtained with a closed loop configuration.

As an example, assuming that:

- the distribution of LV customers is homogeneous for each branch;
- the total number of LV customers is equal to 800;
- the average fault ratio for each automated branch is two permanent faults per year with an average time of refeeding of 4.5 minutes,

it is possible to calculate and compare the quality of service indexes for the two different network configuration considered, obtaining the following values:

- Average duration of interruption (radial) = 22,5 min / customer / year
- Frequency of interruption (radial) = 8 interruptions / customer / year
- Average duration of interruption (ScheMa) = 9 min / customer / year
- Frequency of interruption (ScheMa) = 2 interruptions / customer / year

With the transition to closed-loop configuration and with Sche.Ma automation, the benefit is up to 60% in terms of duration and to 75% in terms of number of interruptions.

In order to estimate what is the optimal number of secondary substations to be automated with Sche.Ma. logic, in Figure 5 the trend of the average duration of interruption for LV customer is shown depending on the number of Sche.Ma. automated secondary substations.

It can be noted that the increase of the benefit resulting from an insertion of a new automated secondary substation becomes negligible after 8 - 10 units installed. In this Project the choice is to automate 9 existing substations in ScheMa logic.

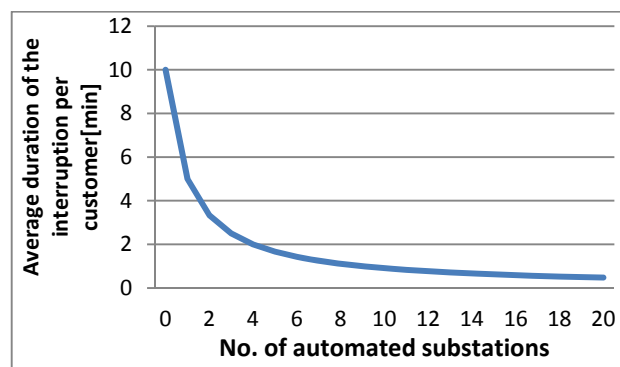

Figure 5. Trend of the average interruption duration per LV customer.

In order to estimate the real benefits for the network chosen in the Project, further analysis were conducted considering the occurrence of permanent faults that really had an impact on the quality of service in the time period of a year (March 1st, 2011 - March 1st, 2012) on the lines "CARRODANO" and "VARESE" and comparing the historical data of customer outages with the number of customers who would have been unsupplied if the same network outages would have occurred in closed-loop configuration. The benefit calculated in case of closed loop operation is approximately 40% in terms of duration of the interruption per LV customers and 60% in terms of number of LV customers interrupted.

CONCLUSIONS

The whole design of the pilot test, including the adaptation and rebuild of portions of the MV network has been made and is awaiting authorization from the local authorities. In 2013 should be completed the whole pilot plant, which will be experimentally operated in closed loop. An analysis of its behavior and of the other MV rings built in Italy within the European Project POI-P4 will be tested to ensure the technical feasibility and affordability, of a closed loop MV network operation, perhaps intended to change future standards governing the performance of networks.

REFERENCES

- [1] S. Botton, R. Calone, L. D'Orazio, A. Fatica, L. Giansante, S. Morel, R. Lama 2011, "Advanced management of a closed ring operated mv network: enel distribuzione's p4 project, *Cired 2011*, Frankfurt, Germany
- [2] L. D'Orazio, R. Calone, 2013, "Innovative protection system on distribution network", *Cired 2013*, Stockholm, Sweden
- [3] R. Calone, A. Cerretti, A. Fatica, CIRED 2011, Frankfurt, June 6-9, 2011, Paper 0507 "Evolution of the Fault Locator on MV distribution networks: from simple stand alone device, to a sophisticated strategic component of the SMART GRID control system component of the SMART GRID control system"