

NEXT GENERATION NETWORK ANALYSIS APPLICATIONS FOR SECURE AND ECONOMIC INTEGRATION OF DISTRIBUTED RENEWABLE GENERATION IN DISTRIBUTION GRIDS

Roland EICHLER
Siemens AG – Germany
roland.eichler@siemens.com

ABSTRACT

Distribution grid operation paradigms of the past such as radial operation with a clear power flow direction from feeder head to consumer have changed dramatically with the increased presence of renewable generation. The paper outlines the components of a distribution network application package that addresses the changed situation. Architectural features are described that respond to the requirements for full applicability of the package in an online environment and at the same time being open for easy integration with corporate IT. An overview on actual smart grid projects applying the package is provided.

INTRODUCTION

In the past distribution grids were radially built and operated with a clear power flow direction from feeder head to consumer. Load flow calculation/optimization along a feeder could be done with sufficient accuracy based on rough guesses of more or less static load profiles. Fault calculation was done only in the planning phase because the feeder head was the only fault current source; contingency analysis was not necessary at all since any outage of a radial grid element meant loss of supply for downstream consumers. Voltage control by OLTC transformers at the feeder head was the only means due to the lack of generation in the distribution grid.

Today renewable generation sources change the voltage profile along a feeder requiring improved volt/var control concepts; they also bring additional fault current sources thus requiring new protection concepts and the recalculation of max/min fault currents during operation. More advanced protection concepts allow meshed grid operation; this fact as well as the advent of distributed generation resources makes contingency analysis in the distribution grid necessary. Finally, running the distribution grid closer to voltage and/or loading limits plus more dynamic load profiles demand a more accurate basis for network analysis calculations i.e. reliable and robust state estimation.

DISTRIBUTION NETWORK APPLICATIONS

The Distribution Network Applications (DNA) suite outlined below provides the tools required for the more reliable and more efficient operation of distribution networks under a dominating presence of injections from renewable sources. The DNA suite comprises various

functional areas (Figure 1): security analysis (YELLOW), optimization (RED), state determination (BLUE), and fault management (GREEN). The latter ones dealing with automated fault detection, fault isolation and service restoration are not discussed further since they do not address renewable generation.

Distribution System State Estimation (DSSE) is a mathematically robust tool for the estimation of the real-time state of the distribution network using all available measurements and load data profiles [1]. DSSE provides (a) improved results over actual measurements and network state as determined from SCADA only, and (b) detection of certain measurement errors. DSSE calculates loads so that their values - initialized from load curves, scheduled loads and/or measured loads - best fit existing measurements and actual network topology. The adaptation of loads uses an optimization process which minimizes the deviation between measured and calculated values. In this course, DSSE consistently corrects incoming mismatched information during the estimation process, including topology analysis, load data, and measured values. DSSE integrates this optimization process together with a power flow engine to calculate nodal voltages and branch flows. DSSE results are used to monitor the real-time network operating state, including transformer loading, voltage profiles and overloads, and serves as a complete, consistent, and reliable basis for other applications.

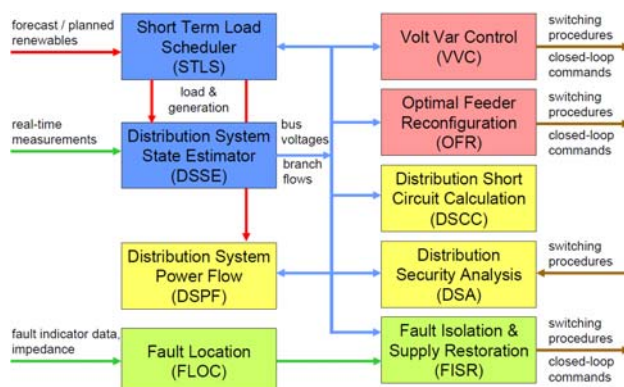

Figure 1: Distribution Network Applications (DNA)

As a post-processing to DSSE, the **Short-Term Load Scheduler (STLS)** maintains a database of load schedules for e.g. up to seven days. Load values are maintained for predefined day types and hourly resolution. An STLS load schedule is updated with the results of DSSE and, if available, with data from Meter Data Management.

Updating is done using a recursion algorithm which smoothes out random or unusual load changes. Scheduled load values provided by STLS are used in any DNA application which requires load data. To complete the picture, scheduled/forecasted injection values for renewables can be provided as well.

Distribution System Power Flow (DSPF) is an efficient and intelligent tool for the evaluation of alternatives and strategies for the real-time network situation, as well as for studying planned configurations under different load and injection conditions in the distribution grid [2]. It calculates the state of the distribution network elements to detect potential equipment loading and voltage limit violations.

Distribution Security Analysis (DSA) determines the impact of faults as well as planned outages on the security of the distribution network. DSA determines the ranking of outages by means of severity indices which are based on unsupplied load, branch overloads, voltage violation, number of (critical) customers that remain unsupplied, and an outage probability index. The calculation is done differently for meshed parts of the distribution grid (including sub-transmission) and radial parts. The DSA simulation includes the effects of restoration/reconfiguration measures after an outage i.e. kind of Fault Isolation & Supply Restoration (FISR) algorithm runs in tandem with the outage simulation. Distributed generation resources can play an important role in the supply restoration plans determined by FISR. FISR is also applied in case of renewable generation outages; the consideration of energy storages as a means for compensating such outages is planned. For providing also a look-ahead view on the distribution grid security DSA simulates all scheduled and planned switching procedures for a certain time window – e.g. 2 hours – into the future.

Distribution Short-Circuit Calculation (DSCC) calculates fault currents in the distribution network to determine potential operating conditions and network configurations that may exceed circuit breaker ratings. It can also be used to verify circuit breaker capacity and protection settings.

Optimal Voltage / Var Control (VVC) is the key application when it comes to (automated) distribution grid adaptations in order to cater for changing injections from renewable sources and/or load changes. VVC provides recommendations for the control of transformer tap changers, switchable shunt reactive devices (typically capacitors) and energy storages in order to keep distribution feeder equipment loading and voltages within defined limits. Particularly energy storages provide essential means for managing rapid changes in feeder loading and voltages due to volatile injections from renewables. Optimization by VVC consists of minimizing an objective function that is user-selectable: minimize power losses, minimize active / reactive power demand, or maximize power revenue. For automated adaptation of distribution grid operation it is essential that VVC can run in closed-loop mode i.e. optimal setting/switching orders calculated by VVC are automatically executed. If so desired, VVC can be switched

to open-loop mode where the optimal setting/switching orders are made available for review in the user interface. A further key application in mitigating the problems of system overloading due to renewable injections is **Optimal Feeder Reconfiguration (OFR)**. OFR determines switching plans and options for feeder reconfiguration accounting for equipment loading.

Distribution network models and the amount of data needed for network analysis can be very large. In addition, the quality of data has significant impact in the feasibility of results. For these reasons a very strong, user friendly **Data Validation Tool** (not shown in Figure 1) is needed that helps users to detect and resolve errors. The tool verifies in an automated way the quality and the completeness of the data necessary to execute DNA functions. The validation can be performed on network elements (lines, switches, etc.), their connectivity, as well as on network parameters (impedances, reactances, and so on).

ARCHITECTURAL ENVIRONMENT

For optimal usability in an online environment the user interface (UI) of the DNA package must be integrated with SCADA. The UI must allow call-up of DNA applications and display of results in one-line diagrams. Thin UI clients are a necessity i.e. no additional installation effort, only a software environment that is available anyway on Windows or Linux PCs such as Java Webstart, and automatic update of new client versions. The UI must form a single application for LAN, Intranet, and Internet access – with compressed and encrypted data transport where necessary. All database maintenance must be done without any impact on the operational database in parallel to its online use i.e. in a secure environment. A database management tool that is common with SCADA provides consistency of data in the overall system at any time. For easy integration with a wider IT environment the database management tool must provide a two-way interface based on IEC 61970 (EMS Application Program Interface) and its extensions according to IEC 61968 (System Interfaces for Distribution). The huge amount of every-day data changes can best be managed by a Job Management concept where a job is a user-controlled set of data changes. Job activation provides the ability to transfer the incremental data changes online to the operational system without interrupt of process control, including the ability to undo changes.

DNA needs to be an integral part of the entire Advanced Distribution Management System (ADMS). Thanks to its service-oriented architecture (SOA), the DNA suite can also be integrated with other surrounding IT systems, e.g. Meter Data Management or Wind Power Forecast, using Web Services or Enterprise Service Bus (ESB) middleware. International standards such as IEC 61968 are applied where available. Thus the DNA suite can become an essential component of any smart distribution grid solution.

SAMPLE SMART GRID PROJECTS

The DNA package outlined above plays a crucial role with the management of modern distribution grids – particularly under the presence of renewable generation. Three according projects are briefly presented in the following each of them being kind of ‘prototype’, ‘study’, or ‘live lab’ - a typical status for smart grid activities of distribution utilities today.

The typical set-up of such projects is a central DMS/DNA component plus several decentralized units on substation / grid cell level. At the central level the overall set-up can be monitored and data can be collected/archived for later studies; decisions can be taken that need information from large parts of the set-up e.g. for keeping voltage limits across defined grid areas (cells). Therefore a DNA package is typically part of the central component. Other components such as Meter Data Management System (MDMS) and Advanced Metering Infrastructure (AMI) or Distributed Energy Resource Management (DERM) and Demand Response Management (DRM) may be part of projects from case to case.

Northern Powergrid / UK: Customer Led Network Revolution (CLNR) project

This three year period trial project set up in the North East of England combines 6 MWh energy storage, enhanced voltage control, real time thermal ratings and demand response. The results shall help make sure the electricity networks can handle the mass introduction of solar photovoltaic panel, electric cars and other low carbon technologies. The project involves Siemens in delivering the Grand Unified Scheme (GUS), a control system which brings together multiple elements allowing them to operate as a smart grid. The GUS located at the central level includes the DNA. DSSE determines the overall electrical network state (voltages), from which it is able to determine the network power flows using DSPF. Based on this, VVC determines optimized adjustments under its control: electrical energy storage, automatic voltage control via OLTC and voltage controllers, and demand side response. VVC enforces constraints such as voltage or power flow which makes it carry out the principal function of the GUS, being the coordinated control of distributed control devices to mitigate network constraints to assist deployment of low carbon technologies. The GUS controller will start operation in May 2013.

Kansas City Power & Light / USA: Smart Grid Demonstration project

The Smart Grid demonstration project – planned to start operation in early 2013 - consists of four major components: distribution network management, distribution network automation, distributed energy resources, and demand response management. It will also include an advanced two-way metering infrastructure, meter data management, time-of-use pricing, hybrid electric vehicle

charging, utility scale battery storage, and rooftop solar technology. Like in the previous project, a hierarchical approach has been chosen: the Siemens Smart-Substation™ controller at the lower level, and the Spectrum Power™ DMS at the central level will be the primary point of integration and the system's backbone for secure and reliable distribution grid operation. The Smart-Substation controller provides a substation information technology platform that enables real-time substation and feeder automation with improved outage response, Volt/VAR control and demand management. Under the DNA modules applied at KCP&L are DSSE, DSPF, VVC, and OFR. A unique feature at KCP&L is that the DNA modules can run at the control center (in a traditional sense) - or control can be given to the substation and it runs autonomously in ‘closed loop mode’ making optimization decisions. If the DNA modules at the substation run into any one of several conditions such as inability to resolve a voltage or flow violation control is then switched over to the control center and the DMS operator will resolve the situation. Once stabilized the operator can then give control back to the substation to run autonomously.

With an evolving energy supply portfolio that uses less predictable generation, the project will enable better integration of renewable energy sources, using a combination of energy balancing strategies, including DRM and DERM. The project will verify technologies essential to increasing deployment of renewable energy sources, facilitate the penetration of other distributed energy resources as well as manage their variability and predictability.

Two-tier volt/var control with ZUQDE

The distributed generation penetration in MV networks creates a new set of challenges for utilities to maintain voltages in an adequate range. At Salzburg Netz GmbH / Austria, Siemens implemented an extension to the distribution control center within the scope of the industrial research project ZUQDE (Central Volt/Var Control in presence of decentralized generation). The automatic control of transformer taps and Q-injections from renewable generators is done with the help of the DSSE and VVC modules together with a closed-loop controller in a two-tier hierarchy (Figure 2): DSSE provides the consistent basis while VVC – starting from this data set - determines updated setpoints such that network losses or the power flowing into the feeder are minimized; voltages are kept within limits. Thus the entire distribution grid can be optimized at a time as opposed to local values only as it was possible with traditional approaches. Since January 2012, the Lungau region in Salzburg in this way is continuously operated automatically, in closed-loop.

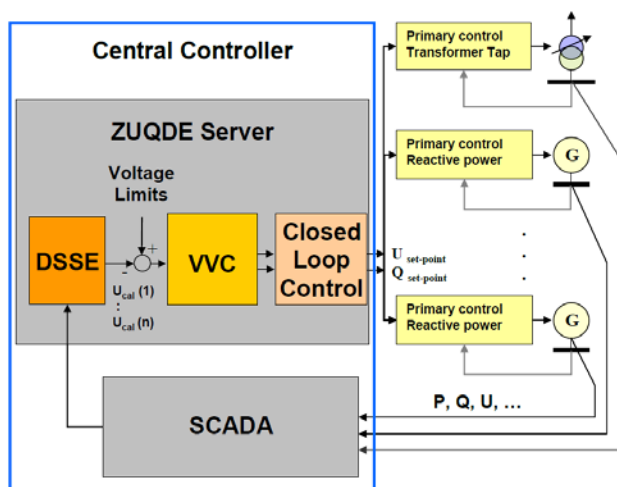

Figure 2: Two-tier volt/var control of renewable generation

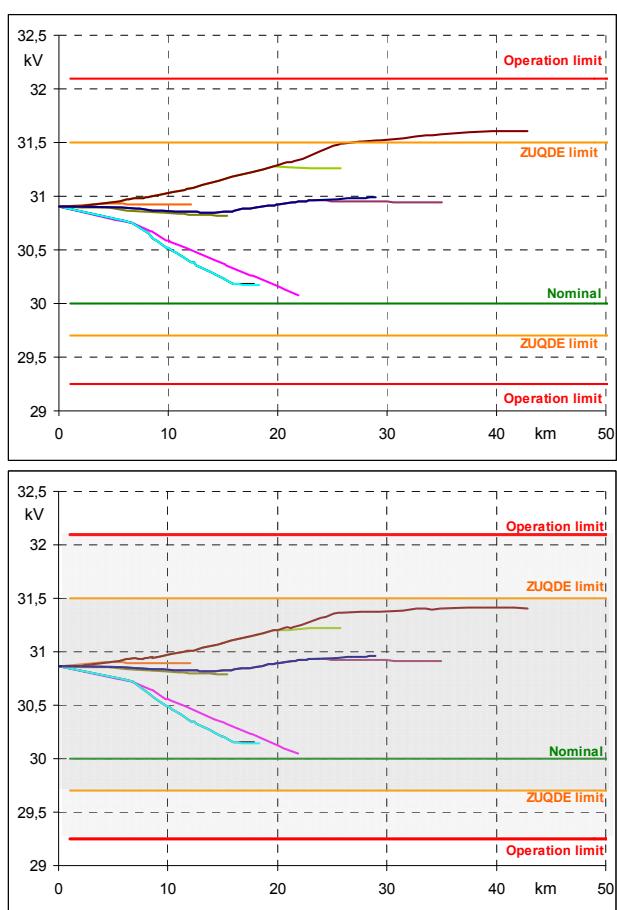

Figure 3: Voltages along MV feeders with Load Drop Compensation (upper), or ZUQDE control (lower)

In a test set-up, the voltage limits for the ZUQDE controller ('ZUQDE') were chosen more closely than normally used ('operation'). With load drop compensation only, the

ZUQDE limits are exceeded on a feeder for about 40% of its length (Figure 3, upper). Since voltage increase along this feeder, power is injected backward from the feeder end into the substation. After activation of the ZUQDE controller all feeder voltages in the test area are kept reliably within the ZUQDE limits (Figure 3, lower). ZUQDE determines the substation voltage at the feeder head high enough to avoid low voltage limit violations in 'passive' feeders; at the same time ZUQDE performs reactive injection control in a way that upper voltage limits are maintained i.e. the voltage spread along 'active' feeders is limited.

The ZUQDE controller mitigates voltage problems arising with the integration of further renewable generators into MV feeders by smart grid means rather than by traditional grid equipment expansion. In a sample case, the addition of three small hydro generators to the distribution grid meant necessary grid expansion by cables of 14 km, 6 km, or 2 km length. After the ZUQDE controller had been introduced the generators could be connected by cables of 50m to 150m length resulting in a cost reduction of about 2.6 million Euros. The extra cost caused by the ZUQDE controller on the other hand was estimated as 30.000 – 50.000 Euros per generator location. Reduction of total integration cost thus is a tremendous advantage that comes with the ZUQDE controller; although the distribution area chosen for the ZUQDE project already today is highly loaded a further 20% increase in renewable generation seems realistic.

OUTLOOK

A DNA package as outlined in the paper increases the observability of the distribution network and provides the user with a fast and complete, real-time view of the current network status (monitoring). Second, it provides the ability to evaluate and optimally select network control actions under a wide variety of what-if conditions in order to restore security in the presence of operational limit violations e.g. caused by frequently and rapidly changing injection from renewable sources such as wind or PV plants. Next development steps will integrate Distribution Load / Generation Forecast in order to do look ahead calculations for non-telemetered feeders as well as closer coordination with local automation schemes (i.e. feeder and substation automation).

REFERENCES

[1] I. Dzafic, S. Henselmeyer, H.-T. Neisius, 2010, "Real-time Distribution System State Estimation", *9th International Power and Energy Conference (IPEC), Singapore*.
 [2] I. Dzafic, H.-T. Neisius, M. Gilles, S. Henselmeyer, V. Landenberger, 2012, "Three-Phase Power Flow in Distribution Networks Using Fortescue Transformation", *IEEE Transaction on Power Systems, Vol. 99*.