

INNOVATIVE SOLUTIONS TO CONTROL UNINTENTIONAL ISLANDING ON LV NETWORK WITH HIGH PENETRATION OF DISTRIBUTED GENERATION

Vito BUFANO

Enel Distribuzione S.p.A. – Italy
vito.bufano@enel.com

Christian D'ADAMO

Enel Distribuzione S.p.A. – Italy
christian.dadamo@enel.com

Luigi D'ORAZIO

Enel Distribuzione S.p.A. – Italy
luigi.d'orazio@enel.com

Cristiano D'ORINZI

Enel Distribuzione S.p.A. – Italy
cristiano.dorinzi@enel.com

ABSTRACT

During the last 3 years the Italian Distribution Network has experimented a dramatic increase of Distributed generation (DG) connected both at MV and LV levels, driven by incentive policies mainly to photovoltaic (PV) generators.

The total amount of DG has reached the record level of 21 GW, out of which 4,2 GW connected to the LV network.

Considering the high penetration of distributed generation the Transmission System Operator (TSO) asked additional technical requirements in the Grid Code to involve DG in the primary regulation during the frequency transient of the transmission grid.

These new requirements have been reflected in a new issue of Italian LV connection standard (Italian Norm CEI 0-21) which foresees that all LV generators (synchronous, asynchronous or static) must be provided with a determined active Power - frequency regulation curve and must sustain the main network in the frequency range 47.5 – 51.5 Hz.

These conditions may cause, under specific network conditions (e.g. MV ground fault) an uncontrolled network island.

This paper focuses on the new connection criteria and on the possible solutions that Enel Distribuzione is experimenting to address the unintentional islanding on LV networks.

INTRODUCTION

As the Distributed Generation (DG) connected to the Italian distribution network reached the record level of 21 GW, the TSO asked additional requirements to the generators in order to comply and participate to the electric system security.

According to these requirements (A.70 Grid Code

attachment and Italian Norm CEI 0-21) all new generation power plants connected to the MV and LV network must be able to provide a capability P-f curve. In particular: active power adjustment (decrease) in case of positive variation (increase) of frequency within the overfrequency range: 50,3 – 51,5 Hz (*P-f overfrequency regulation*).

In general, for all generators is required the following regulation curve:

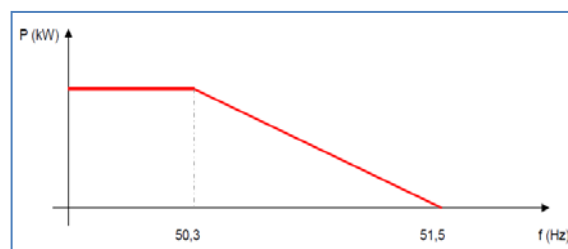

Fig 1: P-f regulation curve of LV generation units.

During overfrequency transients of the transmission system, all generation units will be involved in the primary regulation, decreasing the active power, supporting the system's balance. This kind of regulation allows DG to contribute to the system's security while they are interconnected to the network.

Additionally, the DG must stay connected to the grid in the frequency range 47.5-51.5 Hz in order to sustain the main grid in case of frequency transients due to system's instability (*enlargement of frequency settings*).

The combined effect of the *P-f overfrequency regulation* and the *enlargement of frequency settings* may produce, under specific network conditions, unintentional islanding on the distribution network. This is the case of MV ground fault. In this case, depending on the impedance of the system and operational conditions, the actual settings in the interface protection of the DG unit may not produce the tripping of the protection and the disconnection of the generator.

In the MV network, this occurrence has been avoided

through an additional requirement on the interface protection of GD. Producers have been requested to install devices able to detect a MV ground fault in their substations able to restrict the frequency tripping to 49.5-50.5 Hz. Already-connected DGs are subject to retrofit in order to be compliant to the new requirements.

In the LV network, due to the electrical separation from the rest of the electrical system, it's not possible to use a similar approach to detect MV ground fault and command a frequency setting's restriction on LV generators.

In fact, during an electrical separation from the main network, it's possible that the total amount of LV generation able to regulate P-f could be more than the load. In this case the P-f regulation may adjust the power output to the actual load and create a local power-load balance (unintentional islanding).

Distribution System Operators (DSOs) cannot tolerate this operation condition mainly due to loss of control, safety concerns and equipment's damage risks.

For these reasons Enel Distribuzione has started to investigate different options to avoid the risk of uncontrolled portions of network and to study the unintentional islanding both theoretically and with field tests in order to verify the presence of the uncontrolled electrical island.

Simulations were performed by CESI using ATP (Alternative Transient Program) application. The studies carried out represent a preliminary investigation about unintentional island phenomena. It was considered various model of LV network to simulate different conditions of operation and estimate the value of risk of uncontrolled island. In particular were considered different levels of LV load, production and different types of generation units. Furthermore, but not least, the results of the studies are influenced by the math law of characterization of the electrical loads and by the control algorithms of the static converters. The study is still proceeding and in future the results with all considerations obtained, comparing also these with the outcomes of field tests, will be published.

The field tests performed directly by Enel Distribuzione technicians on MV/LV substations and LV lines are finalized to evaluate the probability to have an uncontrolled electrical island on a LV portion of network. In particular Enel Distribuzione is selecting different typologies of LV circuits where are connected different amounts of power generation, different kind of customers and different types of loads characterized by different curves of consumption. The LV circuits have been selected considering the probability for the generators to supply the total load of the LV line or even a part of it.

The identification of the power plants and LV circuits has been carried out by measuring the following parameters: voltage, current, frequency, phase angle between voltage and current, active and reactive power, THD, as shown in Fig. 2.

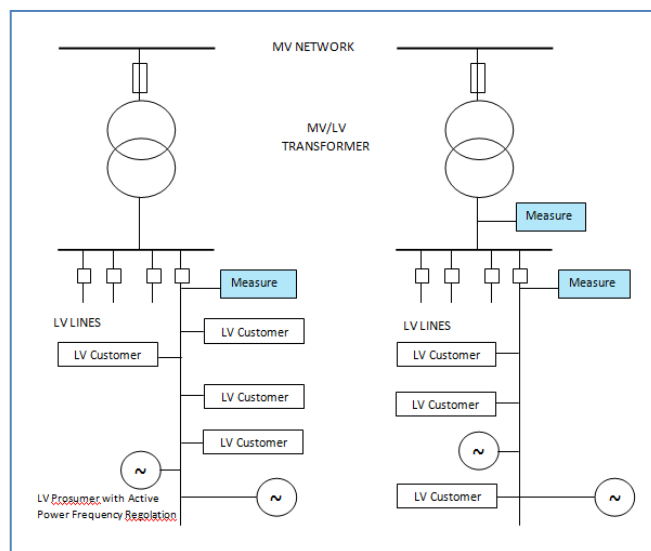

Fig 2: Scheme for measurements during field tests.

The monitoring of the fundamental parameters has allowed to identify the LV lines or secondary substations where carry out the tests, that consist of the intentional opening of the circuit breaker of the LV line, with the consequent separation of the LV line with the rest of network, and to verify the creation of the unintentional island in a portion of the LV feeder and to measure the persistence and duration of the phenomenon, characterizing also the main electrical parameters.

The comparison between the field tests with the simulation results will allow to identify the electrical conditions for which the probability of formation of uncontrolled island is relatively high. Moreover the characterization of the electrical parameters will allow to experiment different triggers and settings of the interface protection of the generators.

Enel Distribuzione is already evaluating several technical solutions to detect and control the unintentional islanding phenomenon.

ANTI-ISLANDING TECHNIQUES UNDER INVESTIGATION

To avoid the unintentional island, Enel Distribuzione is investigation several technical solutions, mainly consisting in:

- Innovative devices installed in the MV/LV substations, able to disconnect generators in case

of network conditions which may cause an islanding event;

- Remote control signals using PLC communication to selectively disconnect generators or restrict the frequency settings.

In both techniques, new equipment in MV/LV secondary substations will be needed:

- new automation system to realize the control of the electrical devices installed on the secondary plants and on the LV network;
- innovative fault detector devices to identify a potential condition for an island operation;
- medium voltage board with voltage, fuse and disconnectors state detectors;
- remote controlled low voltage circuit breakers to opening the LV lines;
- voltage sensors on the LV lines;
- implementation of a communication data system;

All these devices are not independent; in fact they have to be utilized in a coordinated way, as described in following chapters.

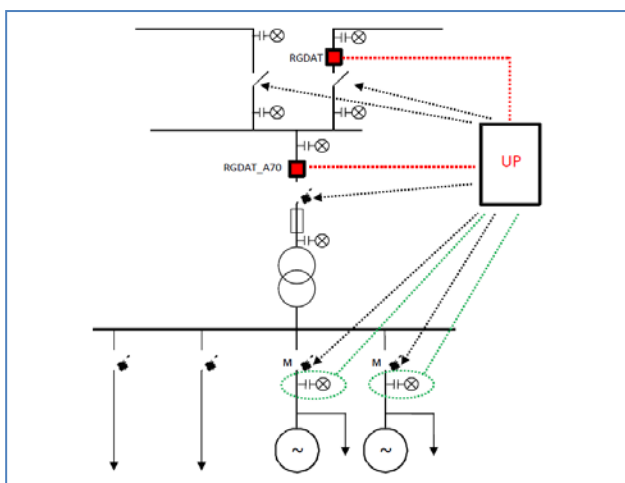

Fig 3: scheme of new secondary substation.

NEW AUTOMATION SYSTEM TO CONTROL A NETWORK ISLAND

In order to avoid the unintentional electric island, the secondary MV/LV substation of the future will be equipped with a new automation system. It will control the switches, the breakers and the disconnectors in specified conditions. The automation is represented by an algorithm that use all the signals sent from the all different devices installed into the secondary substation. In fact, detection of the zero sequence voltage, during an electrical fault, will avoid the MV electrical island formation by mean of dedicated settings in the interface protection of the generators. The MV ground fault signal

will also be used to convey the information to the LV generators.

A LV bus bar uncontrolled island during the maintenance and restoring activities will be detected by correlating contemporary the position of the MV disconnectors and fuse of the MV/LV transformer and the measuring the voltage presence on the LV bus bar.

In order to detect LV line uncontrolled island, is foreseen to detect the voltage level down LV circuit breaker.

Finally, to operate a very efficient and secure management of the network with a high level of penetration of distributed generation connected on LV level, Enel Distribuzione is oriented to implement a new data communication grid to send and receive signals from the generation power plants.

ISLAND DETECTION DURING GROUND FAULT ON THE MV NETWORK

The first case of electrical island creation, analysed in this paper, is the event of a MV ground fault selected by mean of the automation of MV network. In this case, depending on the load conditions and the LV generation amount, the generation power plants installed on the LV network may be able to sustain the load of the separated MV network.

The installation of a new fault detector (called RGDAT_A70) on the medium voltage bus bar of the secondary substation allows to detect the zero-sequence voltage and to command the restriction of the frequency settings or the disconnection of the generators.

ISLAND DETECTION DURING THE OPENING OF MV TRANSFORMER FUSES

The second situation of possible formation of an unintentional island is represented by the opening of the MV fuses of the MV/LV transformer, in case of electrical fault or in case of maneuvers for maintenance or restoring activities. This may cause an electrical island at LV bus bar level. The installation of the new MV transformer's board equipped with the switches position s and the voltage detector at the beginning of each LV line, in the MV/LV substation allow to indentify the presence of uncontrolled electrical island. In this case, for each line where only generation is connected, will be sent an "opening command" to LV circuit breakers. To implement this function, is necessary to install a new particular kind of remote controlled LV circuit breakers.

COMMUNICATION DATA TO CONTROL DISTRIBUTED GENERATION

The control the whole LV distributed generation will be

ensured by mean of a new communication data system, based on PLC technology. This solution consists of the installation of a PLC transmitter in the MV/LV secondary substations.

The zero-sequence detection of RGDAT_A70 or the IMS signaling of the MV/LV transformer in the open position is a result of a fault or of manual operation, will produce a signal transmitted through PLC to interface protections of each generator that controls the restriction of the frequency thresholds of the interface protection.

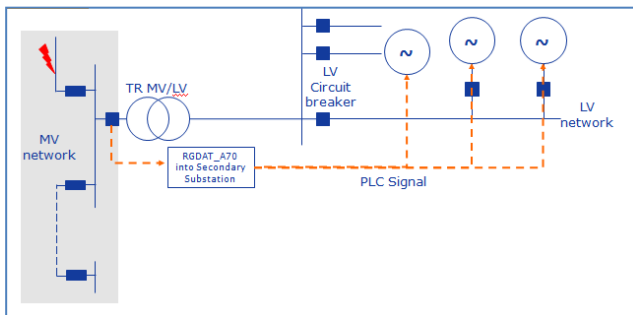

Fig 4: Scheme of communication to control Dispersed Generation

CONCLUSIONS

Taking into account the evolution of the regulation and the standards scenario and the growth of the power generation connected on the LV network, the phenomenon of uncontrolled island could occur in the next future.

Enel Distribuzione foresees to implement new and innovative distributed intelligence in the secondary substations, to ensure the control of the LV distribution network equipments.

At the same time, Enel Distribuzione is defining the best practices to manage these innovative solutions, finalized to the control of unwanted island, in particular on the LV network.

At the end to improve the recognize about the island's phenomena, further investigation is needed.

REFERENCES

- [1] M. Di Clerico, F. Cazzato, D. Di Martino, F. Marmeggi, G. Caneponi, 2013, "THE IMPACT OF DISTRIBUTED GENERATION ON THE ITALIAN DISTRIBUTION NETWORK: UPGRADING OF REGULATORY AND TECHNICAL RULES IN ORDER TO GUARANTEE AND IMPROVE RELIABILITY AND EFFICIENCY OF THE ELECTRICAL SYSTEM", *Cired 2013*, Stockholm, Sweden
- [2] F. Giammanco, L. Giansante, D. Lamanna, 2013, "A LOW-COST HIGH PERFORMANCE MV RMU WITH CIRCUIT BREAKERS FOR USE IN REMOTE CONTROLLED MV-LV SUBSTATIONS: FIRST RESULTS OF ENEL DISTRIBUZIONE EXPERIMENTATION", *Cired 2013*, Stockholm, Sweden