

ACTIVE, INTELLIGENT LOW VOLTAGE NETWORKS – CONCEPT, REALISATION AND FIELD TEST RESULTS

D. GEIBEL, Dr. T. DEGNER,
A. SEIBEL
Fraunhofer IWES – Germany
dominik.geibel@iwes.fraunhofer.de

Dr. T. BÜLO, C. TSCHENDEL
M. PFALZGRAF
SMA Solar Technology AG – Germany
thorsten.buelo@sma.de

K. BOLDT,
P. MÜLLER
E.ON Mitte AG
kai.boldt@eon-mitte.com

F. SUTTER, T. HUG
J. Schneider Elektrotechnik GmbH
f.sutter@j-schneider.de

ABSTRACT

This paper focuses on voltage control strategies applied in active, intelligent low voltage (LV) networks. The aim of these advanced methods is the realisation of a cost-effective integration of high shares of distributed generation by an optimal utilisation of already available network capacities. Newly developed components (a MV/LV transformer with OLTC, adjustable PV-inverters and an intelligent control unit of the LV network) required for this active, intelligent LV network are described.

The components are integrated in a rural LV network with an already high penetration of PV. Different system concepts and operating modes will be tested within this setup. First results are shown and discussed.

INTRODUCTION

This strong increase of installed distributed energy resources (DER) has a major influence on network behaviour. Since the traditional dimensioning of distribution networks had not considered high feed-in, major challenges regarding the network integration of DER units occurs. A broad list of different issues has to be considered, e.g. network equipment utilisation, power quality, network failure behaviour, short circuit contribution and voltage regulation.

VOLTAGE CONTROL IN DISTRIBUTION NETWORKS – STATE OF THE ART [1]

Voltage band limitations are the most urgent challenges which have to be solved. Load limitations of network components usually come with even higher PV-penetration [2]. In the past distribution networks have been designed with regard to the supply case. Nowadays the feed-in of distributed generation, mainly wind in MV and PV in LV, leads to a voltage rise within the distribution network. In traditional network planning only 2% in the MV network and 2-3% in the LV network are assigned to this voltage rise, although the available voltage tolerance band is $\pm 10\%$. This is a limiting factor for a further broad, cost-effective fast and reliable expansion of distributed generation. It has

to be removed by applying new voltage regulation methods in order to avoid costly network reinforcement, since network elements such as cables and transformers are by far not used up to their full capacity yet.

Today, voltage regulation within the distribution network is mainly realised by the on-load tap changer (OLTC) of the HV/MV transformer. Hereby, the voltage at the MV terminals of the transformer can be adapted to present network conditions in order to keep the voltage within permissible limits.

However, the effectiveness of this control method is affected by several reasons (voltage level of the transmission network is not controllable by the DNO, volatile feed-in of wind and PV, spread of voltage profile of the distribution network due to feeders dominated by supply or generation). This implies that new voltage regulation methods in addition to already existing ones are needed. Due to the high number of LV networks distribution network operators are interested in cost-effective solutions with long lifetime and low maintenance effort.

ACTIVE INTELLIGENT LV NETWORKS

Depending on the voltage level from a technical point of view different voltage control strategies can be applied. This control is achieved by either usage of active or reactive power provided by DER units or through usage of advanced network equipment. In general it can be distinguished between local, decentral and central control approaches [3]. Active intelligent LV networks combine decentral and local control strategies. It is assured that the limits of fundamental parameters required for a secure network operation – achieved by coordination of several active network components – automated and without regulation by the network control unit of the network operator are kept. In the following system concepts for these active intelligent LV networks are defined. More details can also be found in [4].

System concepts

Six system concepts, depending on the used components have been defined. They are described in Figure 1. In brief their characteristics can be outlined as follows:

1. Today's status / Conventional

Neither the majorities of the installed PV plants nor the

local network stations are participating in voltage control in the distribution network or provide information for operational control (the only exception is the use of measure value estimates to determine the forecast for network feed-in from PV plants [5]).

2. Active inverters

The PV inverters (INV) vary their active and reactive power depending on set characteristic curves (see [6] and [7]).

3. Smart Substation:

Similar to concept 2. However, there is the option of controlling the inverters from the local network station and process inverter measured values for use in the network control station.

4. Active Substation:

Voltage is controlled using the controllable local network station only using the measured values in the station directly.

5. Active and Smart Substation:

Voltage control using the controllable distribution transformer with OLTC and inverters. In addition, there is the option of using measured values from inverters and the local network station in a harmonized control concept.

6. Electronic Voltage Controller:

Decentralized voltage controllers affects the voltage in the corresponding network branch based on locally measured values.

System Concept	Substation	PV-Plant	Scenario
Conventional	$V_{LV} - V_{MV}$ ($\delta V_{DER} = 3\%$)	$\cos \phi = 1$	Reference
Active Inverter	$V_{LV} - V_{MV}$ ($\delta V_{DER} = 3\%$)	$\cos \phi = 0,9$ or $P_{max} = 70\% P_{nom}$	Inv _Q Inv _P
Smart Substation	$V_{LV} - V_{MV}$ ($\delta V_{DER} = 3\%$)	$\cos \phi = 0,9$ or $P_{max} = 70\% P_{nom}$	Inv _Q Inv _P
Active Substation	$V_{LV} = const.$ ($\delta V_{DER} = 10\%$)	$\cos \phi = 1$	AS
Active and Smart Substation	$V_{LV} = const.$ ($\delta V_{DER} = 10\%$)	$\cos \phi = 0,9$	ASInv _Q
Electronic Voltage Controller	$V_{LV} - V_{MV}$ ($\delta V_{DER} = 3\%$)	$\cos \phi = 0,9$	EVClInv _Q

Figure 1: Selected system concepts of the active, intelligent LV network [4].

CONCEPT REALISATION IN THE FIELD TEST

The most promising voltage regulation approaches and system concepts are validated within a field test under real terms. This field test is carried out in the LV network of Felsberg-Niedervorscht. The network is operated by the German DNO E.ON Mitte AG. The structure of the network can be seen in Figure 5, the used components are described afterwards.

Controllable distribution transformer with OLTC

A newly developed controllable MV/LV transformer (630kVA, 20/0,4kV, $\pm 3 \times 2\%$) has been developed by the project partner J. Schneider. During the development phase importance was put on the fact to build it as compact as a standard distribution transformer. This has emerged as a major advantage. In comparison to state-of-the-art transformers, following hardware add-ons are required:

- Mechanical OLTC with reactor principle
- Control system for the motor unit
- Regulator for voltage regulation
- Potential equalization inductor

Figure 2 shows the active part of the controllable MV/LV transformer with OLTC. Based on state-of-the-art transformers the OLTC and additional required components are added on top. The mounting form allows that standard compact sub-stations can be used. Therefore uncomplicated exchanges in the field and maintenance-free operation up to 700,000 switching operations are guaranteed. Additionally no undefined switching position at a sudden voltage drop due to the potential equalisation inductors can arise.

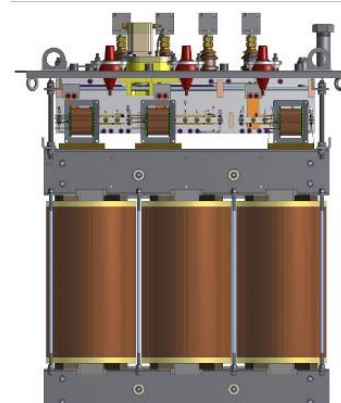

Figure 2: Active part of the controllable MV/LV transformer with OLTC

Adjustable PV-inverter

The PV inverters used for the field test conform to standards like AR-N-4105 and maintain grid voltage support by the capability of an enhanced operation characteristic for reactive power injection. Figure 3 shows the operating area of an inverter for different operating modes distinguishing the Q and cos phi operating mode.

By choosing cos phi operating mode the maximum reactive power is directly limited by the actual injected active power. The reactive power provided is low in set-points where the injected active power is low as well. By using the operating area of Q this disadvantage can be eliminated, therefore this mode (max. settings see bold line in Figure 3) is also used in this test project.

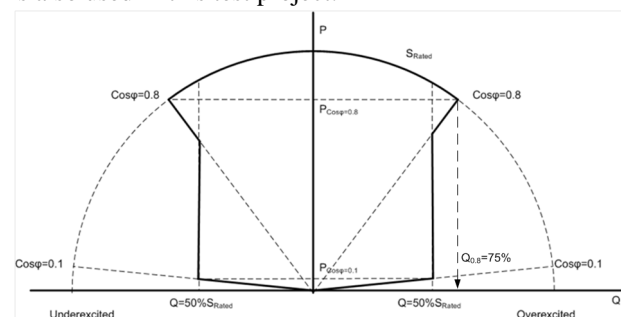

Figure 3: Operating area of the PV inverters

Within this project three independent PV systems are controlled by the smart substation. Two of these systems are located close to each other and to the substation deploying a peak power of 73kWp. The third PV generator with 30kWp is far located from the other two systems. Thereby the differences of the effects on the grid between PV-systems close and far located from the substation can be evaluated.

Communication links

The PV inverters are extended with an IEC 61850 protocol based communication, which is connected to the smart substation using an OPEN VPN-Tunnel established by UMTS routers (see Figure 4). The protocol IEC 61850 provides a comprehensive standardized data model whereof a subset is chosen for the purpose of this project.

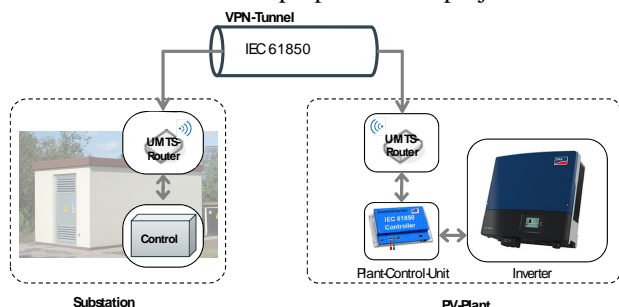

Figure 4: Communication infrastructure for the connection of the inverters to the substations

Table 1: Data model for the IEC 61850 communication

Main function	Description
Basic settings	Gradients active / reactive power
Control functions	Active power limitation
	Reactive power set point
	Q(V) curve
	Cos phi(P) curve
Measurements	Active power
	Reactive power
	Apparent power
	Grid voltage

This subset includes several inverter functions which range from simple to complex. Most inverter functions are based on settings or curves that allow responding autonomously to local conditions, while some do require direct control commands. Also basic settings are configurable and measurements can be requested (see Table 1).

Intelligent Control Unit

The Intelligent Control Unit (ICU) consists of a programmable logic controller (PLC) from the company Bachmann electronic GmbH. The advantage of this system is the high diversity of interfaces beginning from communication interfaces (IEC 61850, IEC 60870-5-104) over an advanced measurement interface up to digital I/O for the control of the OLTC.

The advanced control algorithms are developed with the support of simulation model based software development approaches as well as real-time simulation methods based on MATLAB which can be directly integrated in the PLC. Detailed information can be found in [8].

MEASUREMENT RESULTS

During the field test phase, started in September 2012, different operating modes based on the system concepts are going to be realised. In this paper measurement results of the system concept “Active Substation” are presented. For this system concept the voltage control of the LV network is realised only by using the MV/LV transformer with OLTC and voltage measurement values at the LV busbar of the transformer (Point 1 in Figure 5). Figure 6 shows these voltages on the 9th September 2012. Due to change of the tap position triggered by the ICU, the voltage can be kept within the desired control band of $230V \pm 1.5\%$. With this, the tolerable voltage rise caused by DER can be 10% of the nominal voltage. It also shows that the tap switching is not immediately done when the voltage leaves the control band. In fact the voltage time area beyond the control band is evaluated. After a configurable value is exceeded the tap change is initiated. The parameterisation of the control band and the voltage time area has to be aligned with other time constants within the distribution network, e.g. time constant of the central control of the primary substation or time constants of local controls implemented in adjustable PV-inverters.

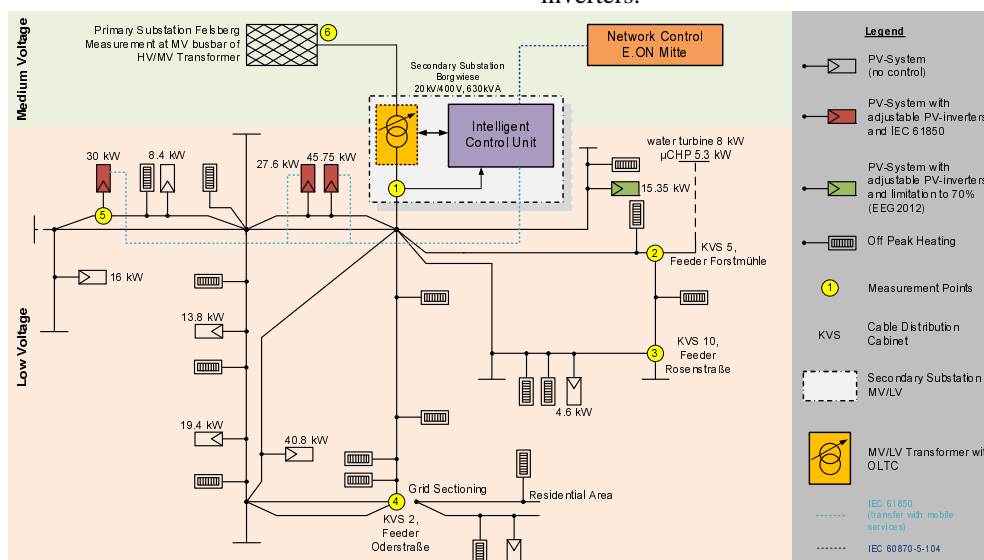

Figure 5: Schematic of the LV network used for the field tests.

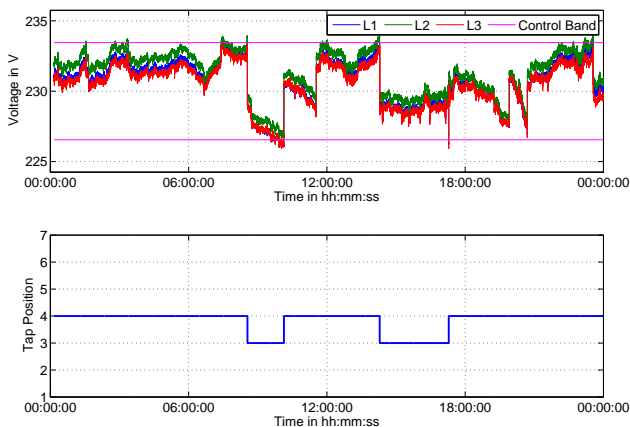

Figure 6: Voltage curves at the LV busbar of the controllable MV/LV transformer.

Figure 7 shows the voltage, current and power curves at the LV busbar of the transformer during a period of 30 minutes. It can be seen that the power flow through the transformer is fluctuating strongly.

Negative power values mean the feedback of active power into the MV level. Although the active power flow varies, a direct influence on the voltage at the transformer's busbar cannot be detected. Only after the switching event of the HV/MV transformer, the MV/LV transformer also switches in order to keep the voltage in the desired control band. This points out clearly that through the usage of the MV/LV transformer with OLTC mainly the fluctuations of the MV level are balanced in order to make an extended voltage band in the LV level for DER units available.

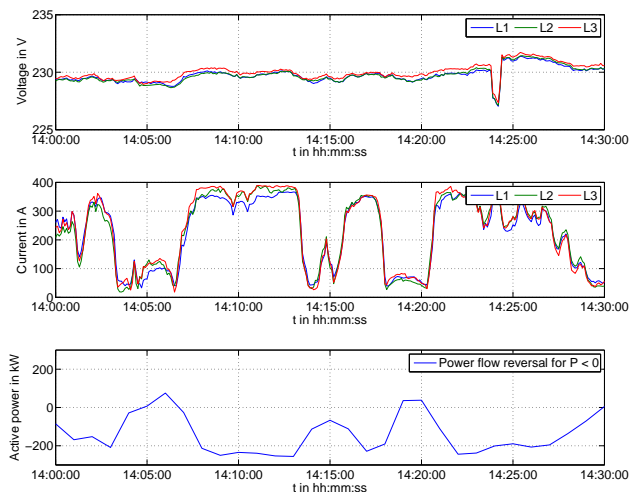

Figure 7: Detailed voltage, current and power curves for the 22nd September 2012.

During the tap position change no additional stress with regard to power quality issues is produced due to an advanced hardware setup of the OLTC. This was found by analyses of several transient recordings during the switching process.

SUMMARY AND OUTLOOK

The paper presents the approach of an active intelligent LV network. Required components had been developed during the project and are now tested in a field test. The existing results of the field test show that the system concept "Active Substation" provides a robust, reliable and satisfactory solution for voltage control in active, intelligent LV networks. During the further field test period also systems concepts with communication between the secondary substation and the DER units within the LV networks will be taken into account. Beyond voltage control additionally services e.g. power flow control of P and Q at the secondary substation are of interest.

In future additionally the integration of storage systems and energy management systems within the LV network could be taken into account for voltage control.

ACKNOWLEDGEMENT

We acknowledge the support of our work by the German Ministry for the Environment, Nature and Nuclear Safety and the Projektträger Jülich within the project "Aktives intelligentes Niederspannungsnetz" (FKZ 0325202). Find more information here: www.smartsubstation.de Only the authors are responsible for the content of the publication.

REFERENCES

- [1] D. Geibel et. al., "Active intelligent distribution networks - Coordinated voltage regulation methods for networks with high share of decentralised generation", CIRED workshop 2012, Lisboa
- [2] D. Mende, et. al.: "Increasing the Hosting Capacity of Distribution Networks for Distributed Generation Using Reactive Power Control – Potentials and Limits" – Solar integration Workshop, Lisboa, 2012
- [3] M. Braun et. al., "Time in the Sun", IEEE power & energy magazine, March/April 2013
- [4] T. Bülo et. al., "Voltage Control in Active, Intelligent Distribution Network", 27th European PV Solar Energy Conference, Frankfurt, Germany, 2012
- [5] D. Beister, "Improved PV grid compatibility through local energy management and precise energy forecasting.", OTTI-Seminar Monitoring and Operation of PV-Systems, 2012
- [6] T. Fawzy et. al.: Integration of Photovoltaic Systems with Voltage Control Capabilities into LV Networks. Elektrotechnik & Informationstechnik (2011) 128/4
- [7] B. Blazic et. al., "Integration of Photovoltaic Systems with Voltage Control Capabilities into LV Networks.", 1st international Workshop on Integration of Solar Power into Power Systems, Aarhus, 2011
- [8] R. Brandl et. al., "Active & Smart Substations: Development and Testing of Intelligent Control Strategies for LV-Networks with High Share of DER", 5th Integration Conference IRED, Berlin, 2012