

## ULTRA FAST RELAY WITH SMALL COMMUNICATION REQUIREMENTS

Cezary DZIENIS  
Siemens AG – Germany  
cezary.dzienis@siemens.com

Joerg BLUMSCHEIN  
Siemens AG – Germany  
joerg.blumschien@siemens.com

Matthias KEREIT  
Siemens AG – Germany  
matthias.kereit@siemens.com

### ABSTRACT

Protection relays play a very important role in network security. Both the network stability and energy availability depend to a great extent on algorithms and protection concepts. This paper presents a novel, very fast protection algorithm that is based on directional comparison. The algorithm is robust against many states and phenomena appearing in the network, e.g. load flow fluctuation, power swings or frequency deviations. The method is also robust against some phenomena connected with secondary system design like CTs saturation, synchronisation deviation or the transient effects in CVTs. The small communication requirements mean that this concept can be applied in existing power networks protected by differential relays with limited band width. The main idea of the algorithm as well as an example is presented in this paper.

### INTRODUCTION

The concept of the ultra fast relay is completely based on the analysis of the delta-quantities. The delta-quantities have their background in the superposition principle as applied to the linear electrical network. They express the difference in voltages and currents during transition between two network states: previous (before an event) and current state (after an event). For the duration of each dynamic event (especially fault) in a power system, the delta-quantities become visible. In order to demonstrate the enormous potential of the delta-quantities for the analysis of power system events, a theoretical example will be discussed here.

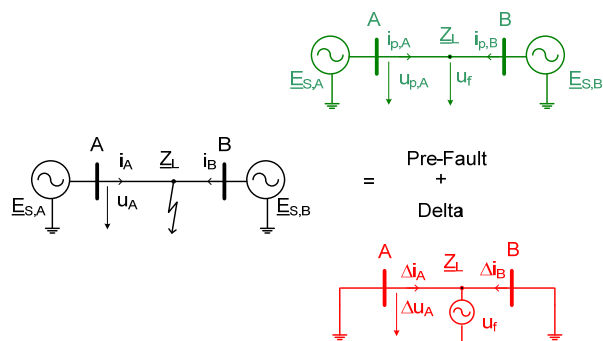

Figure 1: Superimposed representation of the network after a fault on the line

The principle is shown in the simplified single line diagram given in figure 1. The protected line with the line impedance  $Z_L$  is supplied by two sources  $E_{S,A}$  and  $E_{S,B}$ . The

network after the fault can be split, for further analysis, into two independent networks. The network in the pre-fault representation reflects system operation as if the fault did not occur (pure load). The pre-fault components  $u_p(t)$  and  $i_p(t)$  are quantities acquired at normal system operation before fault inception. The network in delta representation reflects the new contribution after the fault event. The delta-quantities  $\Delta u(t)$  and  $\Delta i(t)$  represent the pure fault condition and are used in the algorithm described in this paper.

$$\begin{aligned} u(t) &= u_p(t) + \Delta u(t) \\ i(t) &= i_p(t) + \Delta i(t) \end{aligned} \tag{1}$$

A typical fault current during load condition is presented in figure 2. Before fault inception at  $t=0$ , as shown in figure 2, the measured current  $i(t)$  is equal to the pre-fault current  $i_p(t)$  for  $t < 0$ , which is only related to the load condition. For  $t > 0$  the measured current  $i(t)$  can be interpreted as the sum of the pre-fault current  $i_p(t)$  and the delta current  $\Delta i(t)$ . The delta-current reflects the current change compared to the load condition. As can be observed, the delta-quantities deliver completely new information resulting only from the fault occurrence.

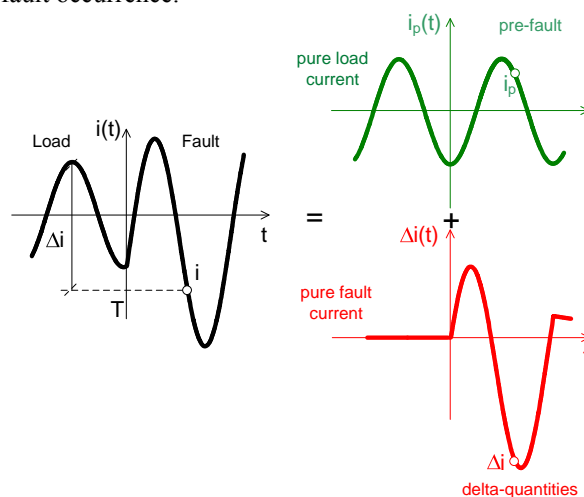

Figure 2: Superposition of the current

From the numerical point of view the delta-quantities can be created from the actual measured quantities and pre-fault values (memorized values) as presented in the figure 2.

$$\begin{aligned} \Delta u(t) &= u(t) - u(t - T_0) \\ \Delta i(t) &= i(t) - i(t - T_0) \end{aligned} \tag{2}$$

where  $u(t-T_0)$  and  $i(t-T_0)$  are values with the delay of the integer number of fundamental periods. Experience has shown that using memorized values with a single fundamental period delay is the best compromise between quality, availability as well as robustness of the delta-

quantities.

Based on sampled delta-quantities fault detection, the loop selection and the directional comparison are realized as a complete very fast protection function.

### FAULT DETECTION

A fault detector using an adaptive threshold created from delta-quantities was designed to release the protection algorithm only in case of a real network fault.

The method is based on the rectified delta-phase-to-phase currents. A network fault is detected if the magnitude of a delta-phase-to-phase current exceeds the adaptive threshold:

$$|\Delta I_{p-p}| > \Delta I_{threshold} \quad (3)$$

The threshold consists of the weighted rectified delta-phase-to-phase current with some delay added by a constant part that is dependent on the nominal current  $I_N$  for security reason:

$$\Delta I_{threshold} = A \cdot |\Delta I_{p-p}(t - \tau)| + K \cdot I_N \quad (4)$$

The weight factors A, K and the time delay  $\tau$  determine the adaptability and sensitivity of the fault detector. The response speed also depends on these parameters.

Most importantly, the adaptive threshold is created from delta-quantities. Thereby signal changes and other disturbances not related to  $f_N$  will influence the adaptive part of the fault detector. In case of network disturbances like frequency deviation, power swing, load flow fluctuation, harmonics etc. the threshold adapts to the actual state.

Only in case of abrupt changes in the fundamental component of the currents will the fault detector pick up and release the protection algorithm.

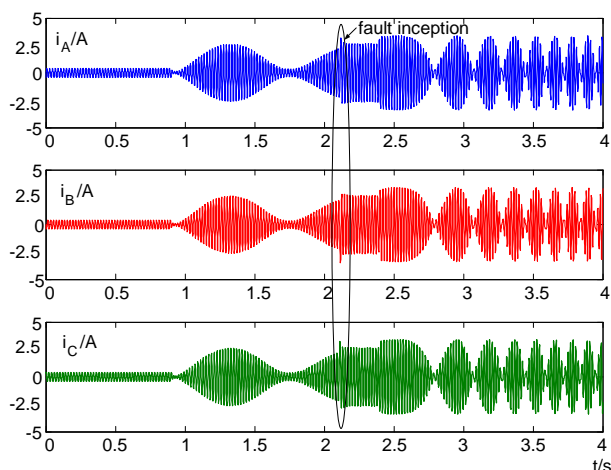

Figure 3: Three pole fault during power swing

Figures 3 and figure 4 (zoom on the fault) show the pick up of the fault detector for a network fault during power swing. The power swing itself does not pick up the fault detector because the adaptive threshold adapts to the changing currents. The fault detector responds only after the fault inception. The same behavior is expected during load

frequency fluctuation as well as during some disturbances not related to fundamental components.

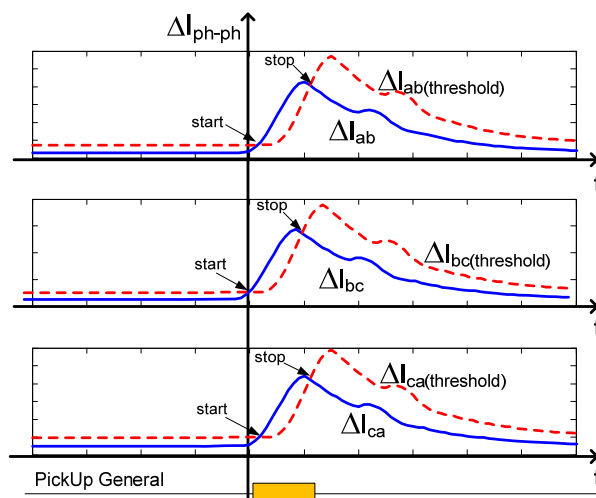

Figure 4: Fault detector response in case of a fault during power swing (case from figure 3)

### LOOP SELECTION

The faulty loop can also be determined based on the delta-quantities. Taking into account delta-phase-to-phase currents one can distinguish between single and multiple phase faults, and furthermore, the phases in which the fault occurred can be selected. Thus, the following statement can be made: for a single-phase fault the delta-current for healthy phases is close to zero; if a double phase fault appears then the delta-phase-to-phase current in unhealthy phases is much larger than other phase-to-phase delta-currents; in case of a three phase fault all phase-to-phase delta currents are equal to each other.

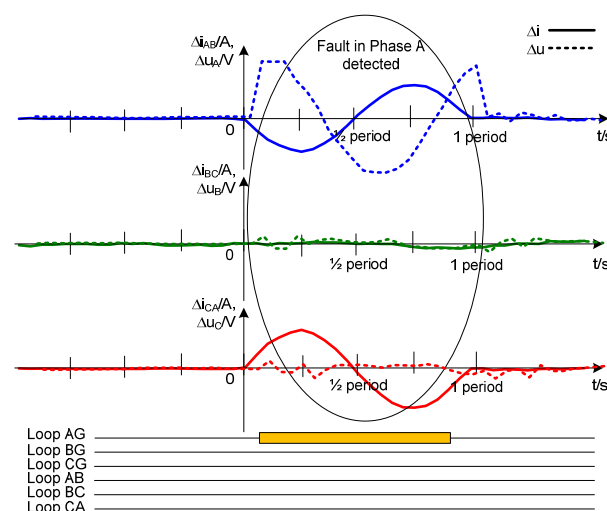

Figure 5: Delta quantities during single pole to earth fault

Since the loop selector only has a short time to decide which loop is picked up, the confirmation of the faulty loop

must be carried out. This can be realized by means of the delta-voltages. If a single pole fault appears the voltage breaks down in the defective phase and the ratio between the delta-voltage in the faulty phase to the delta-phase-to-phase voltage in the healthy phases is high.

In the case of a recognized two-pole short circuit the ratio between the unhealthy phase-to-phase and the non-faulty phase is investigated. If this ratio is high the phase-to-phase loop is confirmed. For three-phase faults the ratios between delta-voltages are equal to each other. Such a two step loop selector is very reliable.

### DIRECTIONAL ELEMENT

The basic principle of the directional element will be explained by analyzing the equivalent circuit for the delta-quantities for forward and reverse faults according to figure 6.

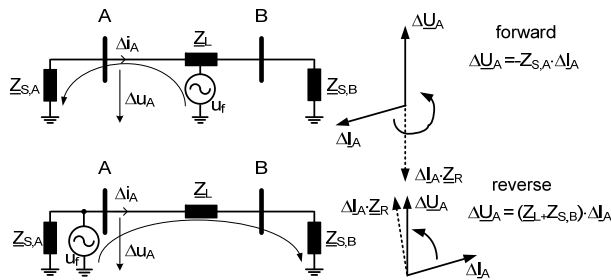

Figure 6: Forward and reverse fault with phasor representation

For a fault in the forward direction, the relay at bus A measures the voltage drop across the source impedance  $Z_{S,A}$  due to the fault current  $\Delta i_A$ :

$$\Delta u_A(t) = -Z_{S,A} \cdot \Delta i_A(t) \quad (5)$$

It can be seen that the changes in voltage and current have different polarity for a forward fault.

For a fault in the reverse direction the relay at bus A measures the voltage drop across the source impedance of the remote end  $Z_{S,B}$  and the line impedance  $Z_L$  due to the current  $\Delta i_A$ :

$$\Delta u_A(t) = (Z_{S,B} + Z_L) \cdot \Delta i_A(t) \quad (6)$$

The changes in voltage and current have the same direction for a reverse fault.

To determine the fault direction as quickly as possible sampled measured values are used for the directional element.

Assuming that the line impedance and source impedances have a similar angle, a universal parameter in the form of replica impedance  $Z_R$  is used to obtain the best result for the directional element.

For stabilization and speed of the directional element an integral function is used:

$$F(\tau) = \int_0^\tau \Delta u_A(t) \cdot (Z_R \cdot \Delta i_A(t)) dt \quad (7)$$

A negative value from the function F indicates a forward fault direction, while a positive value points out a reverse fault direction. The start of the integration is initiated by the fault detector, which exactly recognizes the beginning of the fault. Such synchronization is very important, especially if pre-fault quantities include disturbances resulting from a previous fault or power swing. Without synchronization to the fault detector, the directional element can be polarized with non zero initial condition and contribute to under- or over-function.

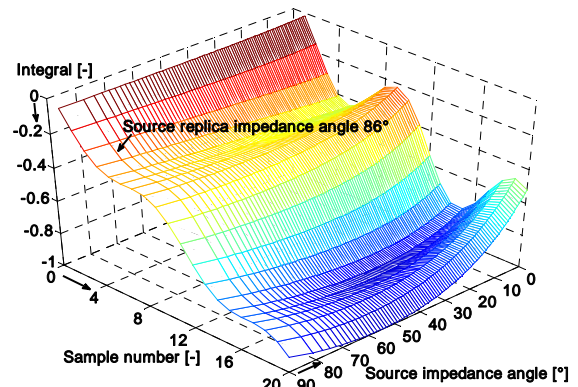

Figure 7: Sensitivity investigation of the directional algorithm (forward fault)

In figure 7 the sensitivity investigation for the angle of parameter  $Z_R$  is presented. This parameter has an impact on result stability. As can be observed, a significant deviation of this parameter from the real value does not limit the correctness of the response. With increasing deviation of the  $Z_R$  angle the response quality decreases. However, this influences the response time only.

### PROTECTION DURING CT SATURATION

After the fault inception, the protection relay picks up. The pick-up behaviour is initiated through the fault detector. During pick-up of the relay, the loop is selected and the fault direction is calculated. The direction result for each loop is exchanged between two devices through the communication port, whereby a protocol with very short message (max. 2 bytes) is needed. In addition, synchronization between devices is not necessary with this approach. The synchronisation takes place to the fault detector for each device separately. If the same results (fault in forward direction) from both sides of the network appear, then the devices trip. The clear faults can be tripped quickly, mostly under half a fundamental period. The high speed of this protection function does not limit its stability or safety in operation, especially in cases when disturbing phenomena accompanying the fault appear. This situation will be discussed here based on the CT saturation. The investigated system is presented in figure 8. The line situated between two sources is protected by the function described above. The external single pole to earth fault is initiated so that the devices should not trip.

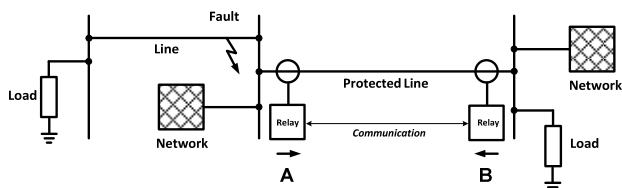

Figure 8: Network scheme during the fault

In order to demonstrate the quality of the algorithm during an extreme situation, the current from side A (reverse fault direction) is disturbed by CT saturation. It is a typical situation in which some differential and distance protection algorithms fail.

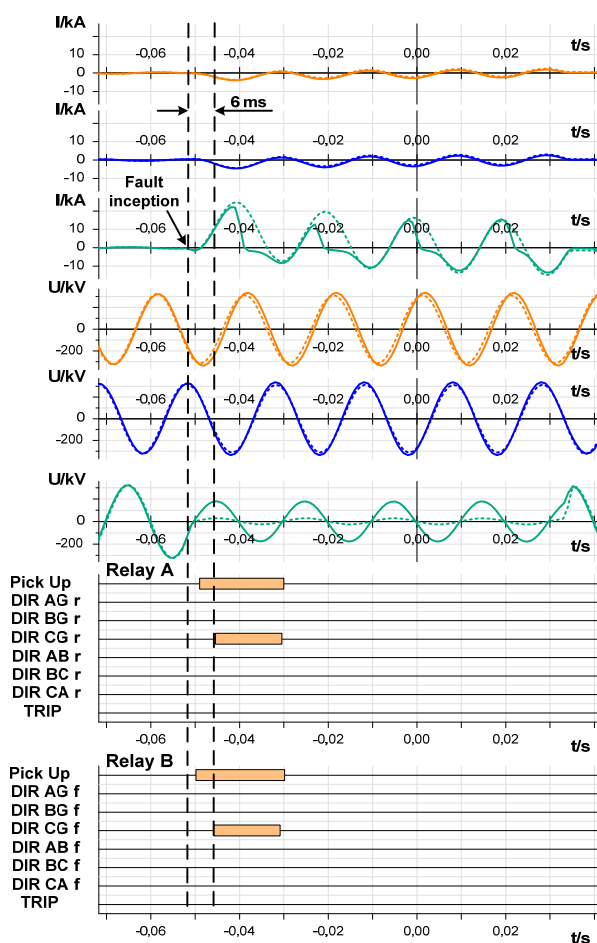

Figure 9: Fault record – external single pole to earth fault

Figure 9 presents the fault record from the external fault acquired from the tested devices, which are configured as seen in figure 8. As mentioned, the current from side A reflects a strong CT saturation effect. The current from side B is not disturbed. All values were referenced on the primary side. After the fault both sides pick up and the appropriate loop is selected. Since the saturation free time is about a fourth of the fundamental period, the integral direction element is pointed out very quickly on the reverse

fault. Since device A points out the reverse fault direction and device B the forward fault direction, no trip signal appears. If the saturation free time is extremely short the algorithm is blocked and no result is produced, i.e. the devices do not trip. The stabilisation of the algorithm is achieved through the investigation of the curve monotony for voltage and current. This means that the algorithm is disabled if the values deviate strongly from the sine curve.

**SUMMARY**

In this paper the ultra fast protection algorithm was presented. This function would definitely be of interest to every energy utility that has problems with the quality of the digital communication channels available between line differential relays. Additionally, there is still doubt about synchronizing the line differential devices with GPS and detection of communication propagation delay changes in digital networks. This directional comparison scheme would therefore provide similar speeds and selectivity to line differential protection but without the need to have perfectly synchronized communications. Furthermore, the proposed protection scheme does not need a high band width for sending the directional comparison result. The presented example demonstrates that the high speed property does not introduce limitations to the algorithm operation. In addition, disturbances accompanying the fault like frequency fluctuation, power swing and load fluctuation do not narrow application area of this function.

**REFERENCES**

- [1] J. Blumschein, C. Dzienis, M. Kereit, 2012, "Directional Comparison based on High-Speed-Distance Protection using Delta-Quantities", *Proceedings Southern African Power System Conference*, AIM, vol.1, 210-220
- [2] C. Dzienis, M. Kereit, J. Blumschein, Zhou Wen, 2011, "Analysis of High-Speed-Distance Protection", *International Conference on Advanced Power System Automation and Protection*, vol. 2, 1330-1336.
- [3] C. Dzienis, M. Kereit, J. Blumschein, M. Claus, 2010, "An Experimental Analysis of High-Speed-Distance Protection", *Modern Electric Power Systems*, ISBN 978-83-921315-8-8, 1-8.
- [4] M. Vitins, 1981, "A fundamental concept for high speed relaying", *IEEE Transactions on Power Apparatus and Systems*, vol. 100, 163-173.
- [5] M. Chamia, S. Liberman, 1978, "Ultra High Speed Relay for EHV/UHV Transmission Lines – Development Design and Application", *IEEE Transactions on Power Apparatus and Systems*, vol. 97, 2104-2112.