

ADVANCED SMART MULTI-METERING: SYNERGIES BETWEEN GAS AND ELECTRICITY SECTORS FOR EFFICIENT OPERATIONS AND CUSTOMER AWARENESS

Marco COTTI
Enel Distribuzione SpA – Italy
marco.cotti@enel.com

Fabio VERONI
Enel Distribuzione SpA – Italy
fabio.veroni@enel.com

Paolo GIUBBINI
Enel Distribuzione SpA – Italy
paolo.giubbini@enel.com

ABSTRACT

The technical solution described in this paper enables energy operational efficiency across different energy sectors, leveraging on the synergies with the smart electricity metering infrastructure, while empowering consumers to optimize energy use and enabling value added services. Pushing forward the concept of converging energy infrastructures, solutions for smart gas metering with advanced functionalities are here described taking the opportunities of the solutions deployed in Italy by Enel in the electricity sector.

The converging energy infrastructure described is potentially replicable even in other utility sectors like water and public illumination, towards the concept of multi-service infrastructure.

INTRODUCTION

Operational efficiency and customer awareness have been priorities in smart grid developments. Directive 2006/32/EC [1] on energy end-use efficiency and energy services addressed enabling consumers to make better informed decisions on individual energy consumption, while ensuring system efficiency and reliability. Member States shall ensure the implementation of intelligent metering systems that shall assist the active participation of consumers also in the gas supply market. The implementation of those metering systems is subject to an economic assessment of all the long-term costs and benefits to the market and the individual consumer, while considering the form of intelligent metering economically reasonable and cost effective within a feasible timeframe for their distribution. As of February 2011, six European countries had conducted a cost-benefit analysis (CBA) on gas smart metering: Austria, France, Hungary, Italy, Netherlands and UK and only Hungary had a negative outcome. Also in the recent Directive 2012/27/EU [2], setting a more reliable billing on the basis of real energy consumptions by 2014, smart metering is identified as a key tool for these goals. Following up the European regulatory framework, the Italian Regulator (AEEG) first set ambitious objectives of roll-out of gas smart meters by 2016 under Resolution ARG/gas 155/08 [3], while introducing the minimum functional requirements of the new generation of gas smart meters for remote reading and control.

Whereas the roll-out of electricity energy smart meters has been completed in Italy and advanced solutions also aiming

to enhance customer awareness tested and developed, advances in gas smart grid solutions have started only recently though. For instance, in the electricity sector, Enel has developed in addition a cost effective device called smart info, providing consumers with a smart interface able to enhance their consciousness on more efficient energy consumptions, while enabling advanced functionalities, like in-home energy management and active demand. Information is provided through a wide range of standard media (such as personal computers, dedicated displays, white goods) that are available in the market.

Therefore, the following Resolution ARG/gas 28/12 [4] pushed forward the deadline for the gas smart metering roll-out to 2018, identifying also in synergies with advanced solutions for smart multi-metering from other commodities like electricity energy sector the leverage for objective economies and high efficiency. The launch of multi-utilities pilot projects is planned for late 2013 for the validation of the technical solution and governance.

As a matter of fact, in the scenario of gas smart metering deployment, the expertise already available for the electricity sector makes the synergies with the electricity infrastructure a crucial driver for the massive deployment of advanced functionalities. In fact, the solutions experienced, properly replicable in other energy sectors, enable time and cost efficiency, enhance technical effectiveness, reduce the need for research and development while supporting regulatory changes and technological progresses.

TECHNICAL SOLUTION DESCRIPTION

With mandate of the Italian Authority, the Italian Technical Committee for Gas (i.e. Comitato Italiano Gas – CIG) has defined under UNI/TS 11292-1 (2010) [5] the reference architectural model for gas smart meter remote reading and management.

A sketch of the overall architecture proposed in synergy with the electricity energy smart metering is reported in Figure 1. In particular, the WM BUS protocol assure a point –multipoint communication between the gas smart meters and the concentrator, which is installed in the MV/LV substations, supporting data aggregation, remote operations and alarm signal detection. A GSM/GPRS system provides instead the communication between the concentrators and the central system, mainly responsible of meters remote management, information processing and quality of service monitoring. While gas and electricity energy feature distinctive meters, the concentrator is going to be a single device for two ways communication, able to receive and

collect the information coming from the customer premises from either gas or electricity meters, then using the same communication infrastructure to the Distribution System Operators (DSOs) System Acquisition Centre (SAC) and Technical Validation System (i.e. AMM). The SAC, featuring also a control room, is mainly responsible for the management of the concentrators and for the communication between the meters and concentrator. The AMM carries out technical validation of the remote readings, while performing also meter status monitoring, acquisition of quality of service parameters and diagnostic. It has to be mentioned that the solution described is quite flexible, offering a set of possible combinations as from Table 1, thus introducing several advantages better explained in the following section. In fact, the combination of responsibilities between the gas and electricity energy commodities might properly change, matching different needs and features.

be made available to customers by several means and devices, for instance via web, contributing to enhance customer awareness and enabling more informed decisions.

MAIN FEATURES AND BENEFITS OF THE PROPOSED INFRASTRUCTURE

The Italian Regulator in its Strategic Plan for 2012-2014 has put metering improvement as one of the crucial objectives, highlighting the opportunity raised by multi-metering systems as a key tool.

Alongside the benefits of smart metering, like more accurate billing, monitoring and control, energy savings together with more accurate information for gas storage, transportation and balancing at system level, the availability of an already experienced infrastructure as from the electricity sector raises important opportunities for high operational efficiency, optimized efforts and benefits.

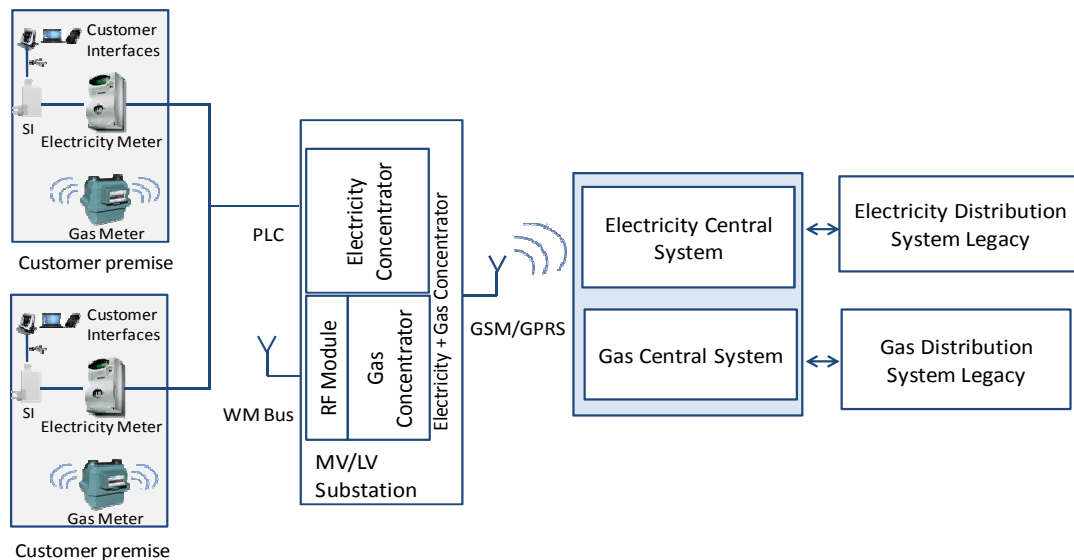

Figure 1. Sketch of the overall architecture.

For example, the electricity energy distributor (DSO) might be either a data carrier or responsible for both data collection and system management.

	CONCENTRATOR	SAC	AMM	AMM CONTROL ROOM
1	X	X	-	-
2	X	X	O	-
3	X	X	X	X

X Electricity Energy (EE) DSO responsible for management

O EE DSO not responsible for management

- No synergies

Table 1. Possible architectural models.

Finally, information on the final energy consumptions can

Leveraging on the synergies with the electricity metering infrastructure and the expertise acquired by Enel Distribuzione in the electricity sector, gas smart metering would mainly benefit a:

- *Lower economic impact*, as investments are optimized both for the commonality of some devices and communication infrastructure, mostly available and already operated for the electricity sector;
- *Lower technological risk*, given the availability of specific know-how and expertise acquired in smart metering, network remote management and control by Enel Distribuzione over more than ten years;
- *Lower time to market*, as technical solution is already available, thus meeting also the roll-out plan set by the Italian Authority;
- *Capillary infrastructure already available over the territory*, which guarantees a distributed wide spread

communication, monitoring and data collection at a lower cost with also battery saving;

- *Higher security*, since concentrators are going to be installed in the MV/LV substations along the electricity energy network.

Advantages from synergies between gas and electricity energy metering would be raised also at system level. In particular:

- *Operational efficiency*, optimizing the use of the communication infrastructure, data acquisition, event management and trouble shouting, given also the high flexibility of the proposed solution;
- *Smart grid perspective*, as converging energy infrastructures are indeed under a framework of integration, which is at the basis of the smart grids and smart cities developments, whereas energy efficiency is maximized and energy infrastructure play a key role towards new services to the customers and advanced functionalities;
- *Replicability*, since the described technical solution can be carried out and replicated also for other combination of commodities (like water or public lighting), still maintaining essentially the same features;
- *Higher reliability*, as the availability of a wide spread infrastructure over the national territory, as earlier mentioned, introduces redundancies into the system, being this way crucial for higher system security and reliability.

MAIN ADVANTAGES FROM SYNERGIES	
GAS DSOs	SYSTEM
Cost effectiveness	Operational efficiency
Lower Technology risk	Smart grid perspective
Shorter time to market	Replicability
Capillary infrastructure	Higher reliability
Higher security	Roll-out independent

Table 2. Main advantages of synergies between gas and electricity smart metering.

It is of fundamental importance to remark that the described technical solution for multi-metering remote reading and control allows a deployment independent from either gas or electricity smart meter roll out.

In some countries, like Ireland and United Kingdom for example, combined gas and electricity meters roll out has been planned by the national authorities.

As a matter of fact, the UK Government announced that it would mandate smart metering for the residential sector for both electricity and gas meters to be fully replaced by

December 2019. Suppliers will be required also to offer an in-home display (IHD) as part of any compliant smart meter installation during both the foundation stage and mass roll-out.

A different scenario is instead in Italy, where electricity smart meters roll-out has been already completed with more than 30 millions of electromechanical meters been replaced. The proposed model highlights then important synergies between the two energy sectors, while offering a solution potentially replicable in other utility sectors disregarding the timing of massive installation of one of those.

SUMMARY AND CONCLUSIONS

In the scenario of gas smart meter roll-out by 2018, synergies between gas and electricity energy sectors are leveraged in the solution proposed by Enel, paving the basis for smart infrastructural integration also for other energy services.

Alongside time and operational efficiency, the proposed converging architecture provides gas distribution system operators with a capillary infrastructure over the territory, thus guaranteeing a high level of communication and monitoring and assuring security and reliability of the service provision.

Several combinations for the same architecture model are possible according to difference features and specific needs, regardless of the electricity energy smart metering roll-out. Multi-utilities pilot projects are going to be launched in 2013 for validating the technical solutions and governance models.

The flexibility featured by the solution proposed by Enel technically fits all the governance models currently under evaluation by the regulatory body. In particular, the acquired expertise in smart metering and the availability of the related infrastructure make the electricity energy distributor able to effectively carry out both data collection and system management.

REFERENCES

- [1] European Parliament and Council, 2006, "Directive 2006/32/EC of the European Parliament and of the Council of 5 April 2006 on energy end-use efficiency and energy services and repealing Council Directive 93/76/EEC".
- [2] European Parliament and Council, 2012, "Directive 2012/27/EU of the European Parliament and of the Council of 25 October 2012 on energy efficiency, amending Directives 2009/125/EC and 2010/30/EU and repealing directives 2004/8/EC and 2006/32/EC".
- [3] Autorità per l'Energia Elettrica e il Gas, 2008, "Deliberazione 22 ottobre 2008 – ARG/gas 155/08".
- [4] Autorità per l'Energia Elettrica e il Gas, 2012, "Deliberazione 2 Febbraio 2012 - 28/12/R/gas".
- [5] Comitato Italiano Gas, 2010, "UNI/TS 11292-1".