

## MODULAR PMU TESTER

Marek HORINEK

VSb-TU Ostrava – Czech Republic  
marek.horinek@vsb.cz

Petr BILIK

VSb-TU Ostrava – Czech Republic  
petr.bilik@vsb.cz

Tomas WITTASSEK

VSb-TU Ostrava – Czech Republic  
tomas.wittassek@vsb.cz

### ABSTRACT

*The PMU (Phasor Measurement Unit) is used for accurate measurement of synchronous phasor of voltages and currents. Based on synchronous phasor continuous measurement at the different location of distribution network is possible prevent fault which can cause blackout. Synchronous phasor measurement is described in IEEE C37.118-2005 standard. The IEEE C37.118-2005 is primarily focused on communication with the PMU and precision of the measurement at steady state. PMU manufacturers declare compliance with IEEE C37.118-2005, which doesn't mean correct behaviour of the PMU for dynamic changes in the power network. The new standard for the PMU is currently developing. This standard should contain both the issues included in IEEE C37.118-2005 and description of PMU testing in connection with dynamic changes in power network. This article deals with the implementation of tests for testing the dynamic properties of PMU. These tests are conducted by tester, which was designed and implemented based on virtual instrumentation. The results of several tests of commercial PMUs are presented in the article.*

### INTRODUCTION

One of the requirements imposed on the distribution network of the electrical network is especially the safety and reliability of electrical energy supplies. At present, the issue of preventive measures how to stop from failure states in the distribution network, which may be the source of large power cuts in the electrical energy system, is often discussed. The importance of this issue is growing with the increasing number of dispersed sources of electrical energy from renewable resources (solar and wind power plants). One of the steps dealing with this issue is implementation of a monitoring system of wide power networks WAMS (Wide Area Monitoring System). On the basis of monitoring, regulatory measures in the distribution network, that can positively influence the stability of the network, can be carried out. The system of monitoring of wide networks uses Phasor Measurement Units (PMU) [1] for the measurement of the parameters of the network. The frame properties of the PMU relating to the evaluation of phasors are defined in the document IEEE C37.118 [2]. This document, however, is focused on the description of communication with the PMU and on the defining of the basic accuracy of the PMU in the steady state. Following text describes an open and flexible testing

laboratory for testing of the PMU units' properties, which was developed at VSb – Technical University of Ostrava with limited financial resources.

### THE ISSUES OF TESTING OF PMU

The methodology of testing of phasor measurement units from the point of view of dynamic behaviour is not described in the form of a standard. IEEE C37.118-2005 defines the basic description of PMU properties, the issue of communication with the phasor measurement unit and defines the accuracy of measurement at steady state. Error evaluation of PMU measurement should be performed on the basis of so called total vector error (TVE).

The standard defines two levels of accuracy at steady state – 0 and 1. The levels differ in the extent of changes of the reference conditions, where the PMU must reach the accuracy of 1% [2]. At the end of the article, results of several tests that were performed in accordance with IEEE C37.118-2005 will be presented.

### THE TESTING WORKPLACE

Since 2010, development of a workplace dealing with the issue of testing of phasor measurement units has been taking place in the Faculty of Electrical Engineering and Computer Science of VSb – Technical University in Ostrava. At the first stage, the hardware concept of the tester was designed which was subsequently put into effect. In the following period of time, the design of the software facilities for testing and the adjustment of the hardware set were carried out. Both the software and hardware work have been performed until the present time.

#### Hardware platform of the tester

The tester is built on the concept of virtual instrumentation. The hardware consists predominantly of components by the company National Instruments. The decision to choose this concept was made on the basis of the long-time experience gained by the staff of our department in the area of virtual instrumentation.

The core of the testing workplace is the system NI PXI that is supplemented with the board of analogue outputs NI PXI-6733 and the board for time synchronization NI PXI-6682. NI PXI-6682 contains a GPS signal receiver that is used for the time synchronization of the generated signal and time synchronization of other devices participating in the test, including the tested PMU. The synchronization signal is transferred to the devices by means of the protocol IRIG-B. The analogue output (AO) is equipped with a 16bit

converter for each analogue output. The maximum sampling frequency for the analogue module used is 1Msamples/s. Two power amplifiers DAP1500 are used for amplification of the analogue signal from the AO card. By means of these amplifiers, the output signal is amplified to a level which is suitable for excitation of analogue signals of the tested devices (PMUs). The tester enables to generate 3 voltage signals. The amplifiers used have the following parameters:

- output performance 2 x 800W / 4Ω load
- frequency range 20–20000 Hz (-1dB)
- input sensitivity 1,55 V non-sym., ±0.707 sym.,

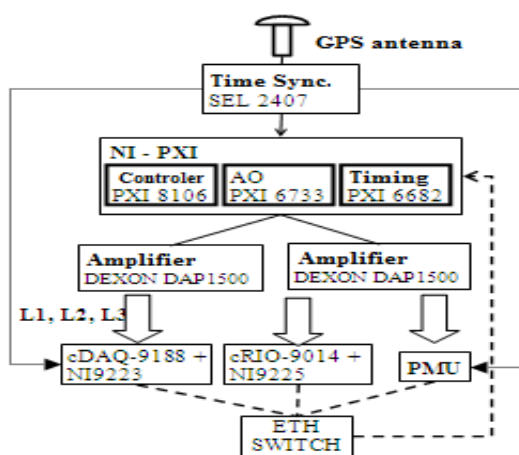

Figure 1. The block diagram of the tester

**The software for generation of test signals**

The software application of the tester is created in the graphical programming language National Instruments LabVIEW. The application consists of several parts:

- Editor of the test signal shape.
- Calibrator – measurement of frequency amplitude and phase characteristics of the amplifiers used.
- Main user menu.
- Viewer to display the stored signal with timestamps.

The main user menu contains elements by means of which it is possible to start generation of the signal on the basis of the selected configuration file, to start the editor for creation of the test signal or to perform calibration of the workplace. The editor for creation of the test signal allows creating of various waveforms of signals for the testing of phasor measurement units. The signal can be created either by a simple shape with constant parameters (amplitude, frequency and phase) depending on the time, or it is possible to create a signal with variable parameters in time, see Figure 3. and Figure 4. This enables a change of parameters that can come to existence in a real electrical network.

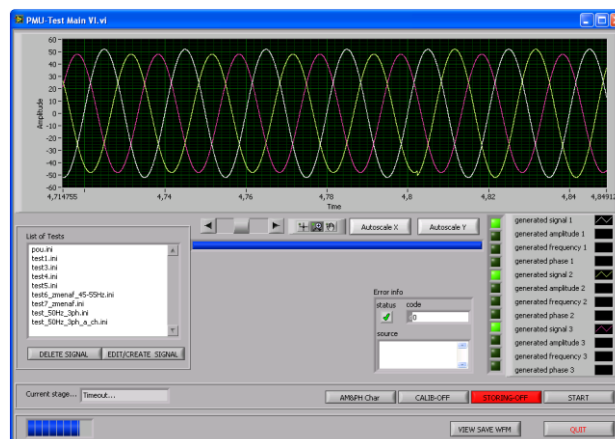

Figure 2. An example of application graphical user interface

The application also performs computation of the theoretical values of the amplitude, frequency and phase of the generated signal. The individual waveforms of the signals can be stored in configuration files and, on their basis, it is then possible to display the testing signal in the main user menu of the application or, possibly, on the basis of the configuration file of the given signal, its generation is carried out.

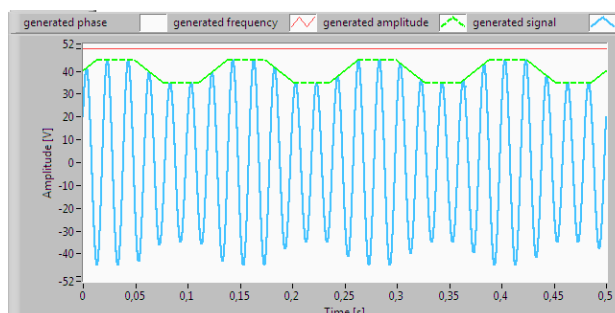

Figure 3. An example of a change of the amplitude of the generated signal

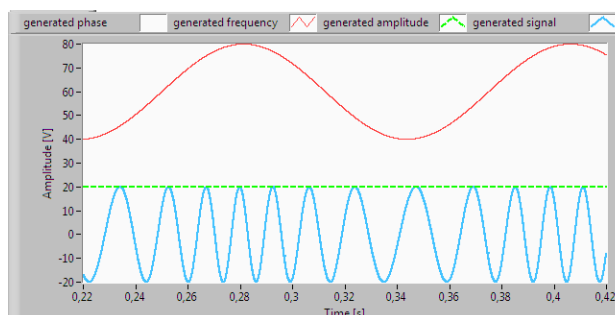

Figure 4. An example of a change of the frequency of the generated signal

The above stated figures show examples of signals that can be used for testing of PMU. Figure 3. shows a signal with variable amplitude in time, Figure 4. shows an example of a signal with variable frequency. Moreover, the theoretical values of the generated amplitude and frequency are shown in the graphs.

**The testing process**

With respect to the fact that audio amplifiers are used for the amplification of the signals for excitement of the input circuits of the tested devices, it is necessary to deal with certain problems concerning the amplified signal frequency dependence. After the measurement of the amplitude and phase frequency characteristics of the amplifiers used, nonlinearity of the amplifiers was found out in the range of low frequencies. This range covers the frequencies (30 – 70 Hz) that are usually used for generation of the test waveforms.

On the basis of the above stated facts, correction of the amplitude and the phase depending on the required frequency is performed when each signal is generated. The correction of the amplitude and the phase of the individual harmonic components contained in the signal are performed in the time domain.

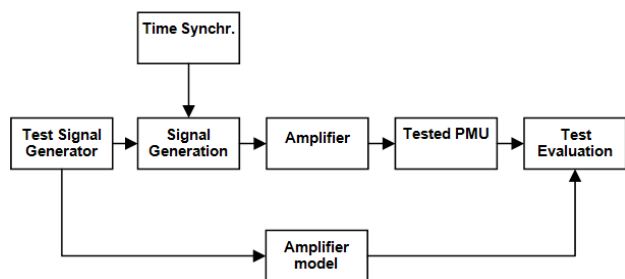

Figure 5. Testing algorithm of PMU

**Results of the partial tests**

The results of one of the tests that describes the behaviour the phasor measurement unit at steady state, i.e. when there are no dynamic changes of the measured parameters (the magnitude of the amplitude, the frequency and the phase), are shown in Figure 7. , Figure 8. and Figure 9. The test is performed in compliance with IEEE C37.118-2005. Two SEL 351A devices by the American manufacturer SEL (Schweitzer Engineering Laboratories) were tested.



Figure 6. SEL351A the protective system with integrated PMU

Parameters of the signal used for the test:

- amplitude 55V
- frequency 49,5Hz
- phase 0°.

The individual waveforms in the below stated figures represent the dependence of the given quantity (amplitude,

frequency, or phase) on time. Each graph shows the curve of the generated quantity and the quantities that were obtained from the tested devices.

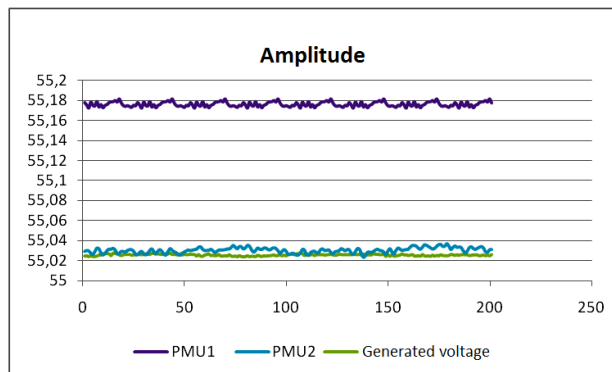

Figure 7. Curves of the measured + generated voltage

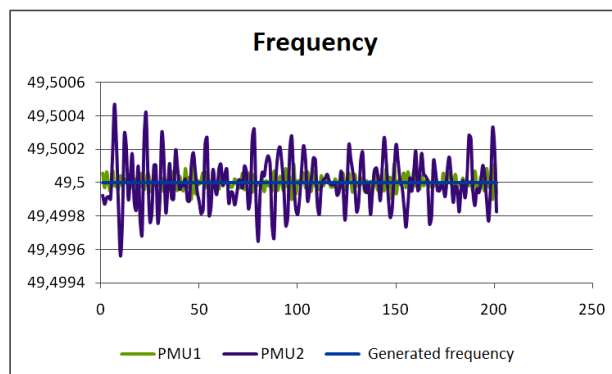

Figure 8. Curves of the measured + generated frequency

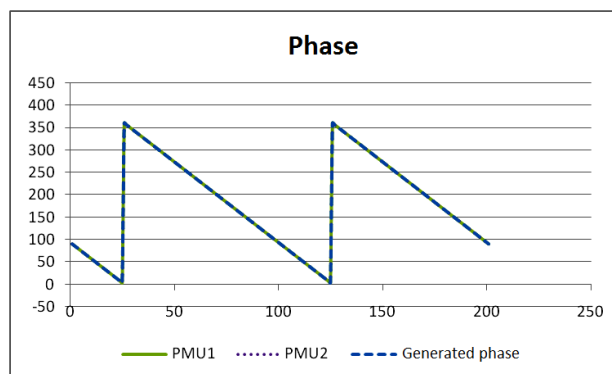

Figure 9. Curves of the measured + generated phase

**CONCLUSION**

For building of the test workplace, the concept of a tester on the basis of virtual instrumentation was selected. This concept is not anyhow limited by the functionality defined by the manufacturer, but, on the other hand, it brings openness and flexibility much needed in a university workplace.

The development of the tester, both from the point of view of the hardware and the software application for creation of tested signals, still continues. Another goal we set is to carry out adjustments of the hardware part mediating amplification of the output signal. Steps are taken in order to improve frequency properties of the amplifiers in the range of low frequencies, which should result in improvement of accuracy of the generated signal. Furthermore, the arrival of a new standard dealing with the issue of testing of properties of phasor measurement units, on whose basis possible changes in the methodology of testing will be made, is expected.

The tests that have been prepared enable to carry out the verification of compliance of the properties of the tested PMUs with the requirements of the basic norm IEEE C37.118, the compliance of the properties with other requirements of the end user and, especially the properties of the tested PMUs at the occurrence of various disturbing factors that may occur in the real network.



Fig.10 A photography of the testing system

In the following research, algorithms for testing of the PMU behaviour for more elaborate conditions will be developed. Multiple repetitions and the following statistic evaluation are integral parts of the tests.

## ACKNOWLEDGMENTS

This work was supported in part by The Ministry of Education, Youth and Sports of Czech Republic under the project KONTAKT II registration number LH12183.

## REFERENCES

- [1] Zidek, J.; Sima, J.; Hrudka, G., "Testing of properties of phasor measurement units", *Proceedings Conference CK Cired 2010*
- [2] IEEE C37.118, *IEEE Standard for synchro phasors for Power Systems*. [s.l.]: IEEE Power Engineering Society, 21.10.2005. 65 s. Accessible from WWW: <<http://ieeexplore.ieee.org/stamp/stamp.jsp?tp=&arnumber=1611105>>.