

## PROTECTION OPERATION ANALYSIS IN SMART GRIDS

Alexander Apostolov  
OMICRON electronics - USA  
alex.apostolov@omicronusa.com

### ABSTRACT

*Protection operation analysis in smart grids can be sufficiently improved based on the functionality of the intelligent electronic devices and the different common data formats for recording and reporting of power system events that can be used for the development and implementation of smart tools for IED operation analysis..*

### INTRODUCTION

The August 2003 blackout in the North-East and the European disturbance in 2006 demonstrated that the analysis of different electric power system events is a very important and extremely complex process. It is required in order to determine the cause of the abnormal system condition, to speed-up the restoration of the affected parts of the system, and to evaluate the performance of different protection and control systems. System events and the effect they have on deviations of the supply voltage may result in failure of sensitive equipment with significant economical impact. To better understand the effects of different parameters of the power supplied to sensitive customers, it is necessary to provide engineers with the right tools to allow them to establish the correlation between the combination of certain attributes of the power and the failure of equipment.

The integration of multifunctional intelligent electronic devices (IEDs) from different manufacturers in substation protection, automation and control systems requires a significant effort due to the different formats of the data available from these devices. Measurements, status, event, disturbance, maintenance or configuration data is used at different times by different applications. The paper discusses the requirements for a common data format for all these different types of data in order to allow the development of tools that will simplify the engineering and analysis process in electric utilities.

One common format that can be used for analysis of event data is IEC 61850, but it covers only a couple of the requirements listed above and is also used only by devices that support the standard. There are ongoing activities in the IEEE PES Power Systems Relaying Committee working on the establishment of common data formats not only for IEC 61850 based devices and systems, but also for any IED with communications capabilities.

The paper introduces the completed and ongoing work on the following common data formats that can help with the

development of tools for automatic protection operation analysis:

- IED configuration data
- IED event reports
- Sampled values based records
- Substation configuration description
- File naming convention
- IED naming convention

The use of all these standard data formats for analysis is described in the second part of the paper.

### ANALYSIS OF PROTECTION OPERATION

The analysis of protective relays operation is based on the different reporting functions in these IEDs. They include:

- Event reports
- Fault records
- Waveform records

In many cases the fault records are included in the event report.

At the same time in order to determine if the relay operated as expected, it is necessary to know what exactly the relay settings at the time of operation were.

The distribution of the fault currents and their magnitude at the time of a short circuit fault also have an impact on the operation of protection devices. That is why the analysis needs to consider the electric power system and substation topology at the time of the event.

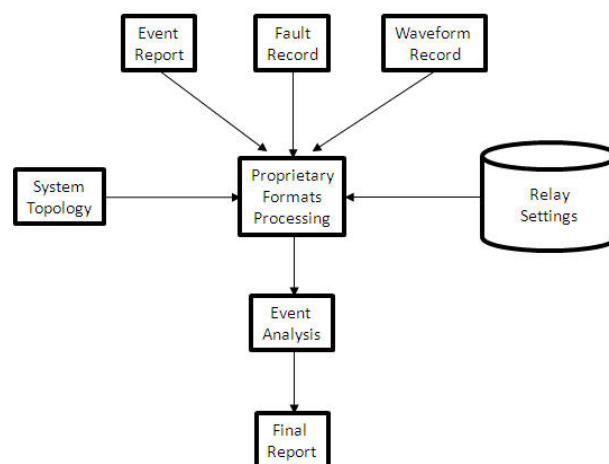

Fig. 1 Protection operation analysis process

The experience from the analysis of many relay operations and system disturbances demonstrates that one of the main problems (other than IEDs that are not time-synchronized) is the fact that all the data available from different devices and tools is in proprietary formats that requires significant effort to convert to a common format in order to perform the analysis. Usually this processing of records and data is done manually, which slows down the process and can also lead to errors that may affect the results from the analysis.

In order to improve the analysis process and create an environment supporting the development of automatic fault and relay operation analysis tools, the industry has been working for years on the standardization of reporting, recording and configuration data.

### IED CONFIGURATION DATA STANDARDIZATION

The description of the functionality of protection devices for many years has been based on the IEEE C37.2 standard that assigns function numbers to substation devices. The problem with this standard is that it has been designed in the twentieth century with electromechanical devices in mind and focused primarily on the representation of substation (including protection) functions on a drawing.

The complexity of the protection functions in modern IEDs and their different possible states that need to be understood during the process of relay analysis cannot be modeled using IEEE C37.2.

IEC 61850 has made a significant progress in the definition of standard description of the functionality of protection IEDs. The fact that any protection function element is represented by a logical node (see an example of an overcurrent protection element represented by logical node PTOC in Figure 2) that can have a Started and Operated state, as well as different modes, associated measurements, settings, etc. allows the detailed description of the behavior of a multifunctional protection IED under abnormal system conditions.

PTOC class				
Attribute Name	Attr. Type	Explanation	T	M/O
LNName		Shall be inherited from Logical-Node Class (see IEC 61850-7-2)		
<b>Data</b>				
<i>Common Logical Node Information</i>				
		LN shall inherit all Mandatory Data from Common Logical Node Class		M
OpCntRs	INC	Resettable operation counter		O
<i>Status Information</i>				
Str	ACD	Start		M
Op	ACT	Operate		T M
TmASt	CSD	Active curve characteristic		O
<i>Settings</i>				
TmAcrv	CURVE	Operating Curve Type		O
StrVal	ASG	Start Value		O
TmMult	ASG	Time Dial Multiplier		O
MinOpTmms	ING	Minimum Operate Time		O
MaxOpTmms	ING	Maximum Operate Time		O
OpDtTmms	ING	Operate Delay Time		O
TypRsCrv	ING	Type of Reset Curve		O
RsdTmms	ING	Reset Delay Time		O
DirMod	ING	Directional Mode		O

Fig. 2 PTOC (Protection Time Overcurrent) logical node

The IEEE PES Power System Relaying Committee understood the need for standardization of the modeling of IED configuration data and started a working group – H5a - in the Relay Communication subcommittee with the task to define a common data format for relay configuration. The idea was to get a consensus in the industry that the function that can be implemented in many different ways by different relay manufacturers, can be represented using a common model and file format. Once this report is published, a new working group will be formed with the goal to complete the models of all remaining protection functions and develop the standard file format to exchange the settings between relay configuration software and different tools used by protection engineers in the analysis of relay operations.

The file format will be based on XML and the substation configuration language as defined in IEC 61850 Part 6. This will allow the import and export of the settings for any multifunctional protection IED (they do not need to be IEC 61850 compliant in that case) in a common format that can be imported into an event analysis tool for the automatic analysis of a protection or other system operation.

### IED EVENT REPORTS

Event reports are available from any multifunctional protection IED and have been used for more than twenty years. They are typically in the form of a record available in the memory of the relay that can be viewed from the front panel or can be extracted locally or remotely using the IED communications capabilities.

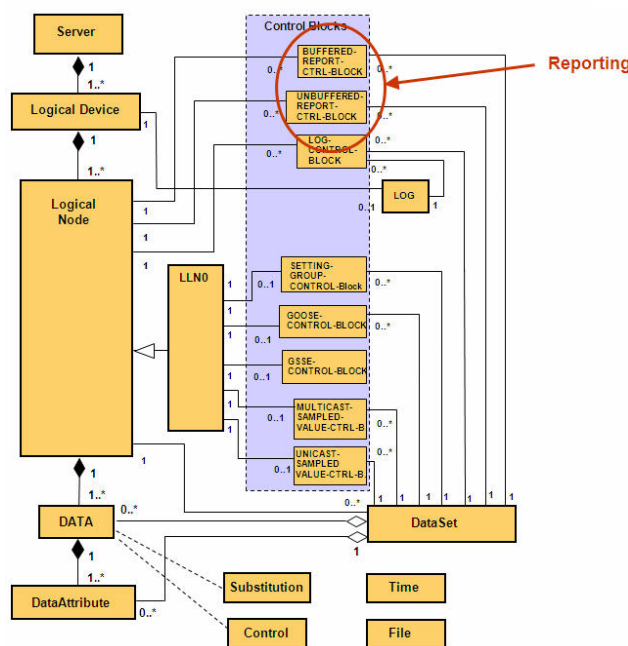

Fig. 3 IEC 61850 reporting services

The format of the event reports are different for the different manufacturers, which makes it difficult to process in automatic fault analysis tools.

IEC 61850 made the first significant step in the development of data models and services that define standard reporting that can be used in automatic event analysis.

Event reports in IEC 61850 are based on Report Control Blocks. They control the procedures required for reporting values of event data from one or more logical nodes to one client. Instances of report control are configured in the IED at configuration time.

IEC 61850 defines two classes of report control:

- Buffered Report Control Block (**BRCB**)
- Unbuffered Report Control Block (**URCB**)

Buffered Report Control Blocks are used for sequence of event purposes. They define internal events (caused by trigger options data-change, quality-change, and data-update) that issue immediate sending of reports or buffer the events for transmission. This prevents from data being lost in case of loss of connection.

Unbuffered Report Control Blocks are quite similar to the **BCRB**. However they don't buffer the data, so event information may be lost in the case of communication problems. Obviously the unbuffered report control block does not support sequence of events reporting in case of loss of communications.

The only problem with the use of the reports described above is the fact that they are available only from IEDs that support IEC 61850. That is why the IEEE PES Power System Relaying Committee understood the need for standardization of the event reporting and started a working group – H5b - in the Relay Communication subcommittee with the task to prepare a Report on a Common Data Format for IED Event Data.

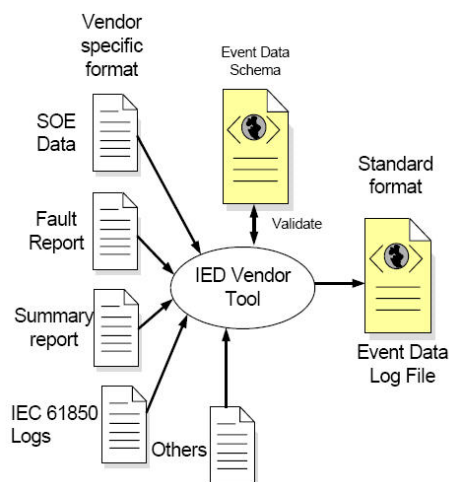

Fig. 4 Event data exchange process

The report defined a common XML-based file format for describing and exchanging event data records collected from power systems. It addressed the fact that protection relays and other IEDs store in their memory historical event data. The main categories of event data considered in this report were:

- Sequence of events (SOE)
- Fault reports
- Summary reports
- IED Status
- other

The content and the format of the data recorded are vendor specific and therefore cannot be easily integrated in a power network post analysis tool.

The main purpose of this file format is to facilitate power systems event data integration and analysis by enabling event data exchange between multiple data sources from different vendor devices and vendor-independent analysis tools.

The report was completed and published in 2008. A new working group (H16) was started with the task to define a new standard. The development and balloting of the standard has been completed and now it is available as C37.239-2010 IEEE Standard for Common Format for Event Data Exchange (COMFEDE) for Power Systems.

## SAMPLED VALUES RECORDS

The IEEE PSRC Working Group H5-c Report on a Common Data Format for IED Sampled Data presented different methods of sampling data in modern IED's. Three standards were identified and reviewed, COMTRADE - IEEE Std C37.111-1999, PQDIF - IEEE Std 1159.3-2002 and IEC-61850. The different data formats, types and attributes to the corresponding standards were compared. Different possible conversions of sampled data between the different standard formats were presented for consideration. Recommended changes to the COMTRADE standard were made in order to harmonize these data between the three standard formats. The recommendation of this working group was that consideration be given to formally harmonize these standards in the next revision of COMTRADE and also to adopt the XML format for self-description of data and file verification. Finally, after that revision is prepared, to have a new working group that will develop a guide for loss-less conversion between these standards for the industry at large in order to support automatic fault analysis.

Advantage should be taken of the definition of the fault and disturbance recording model that defines a standard naming for the different analog and binary channels based on the

standardized names of data objects and attributes defined in different parts of the IEC 61850 standard.

## SUBSTATION CONFIGURATION DESCRIPTION

In order to analyze the operation of a relay, we need to know the substation topology and the association of the individual IEDs with the primary equipment in the substation. IEC 61850 defines the substation configuration description file that supports standardized description of the substation primary and secondary equipment that can be used for automatic fault and disturbance analysis.

IEC 61850 defines four types of files required to support the intended engineering process. In order for an IED or a system solution by a manufacturer to be compliant with the standard, they have to support the use of the files described below directly from the IEDs or through tools delivered with the system.

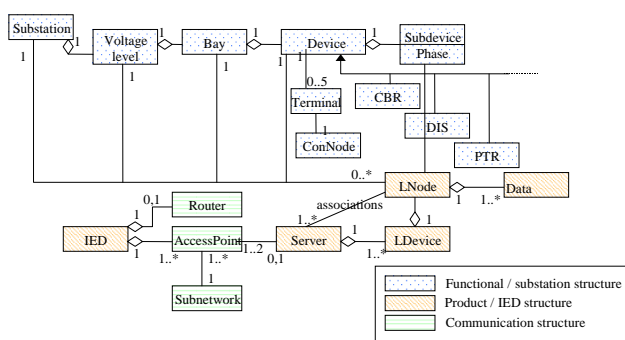

Fig. 5 Simplified UML diagram of the substation configuration language

The data exchange for a system specification tool and other tools should be based on the System Specification Description (SSD) files defined in the standard. They describe the single line diagram of the substation and the functional requirements represented by logical nodes. The logical nodes may not be allocated to specific IEDs.

The default functionality of an IED in the substation configuration language is represented by the IED Capability Description (ICD) file. It is used for data exchange from the IED configuration tool to the system configuration tool. The file also includes the different logical node types as they are instantiated in the device.

The configuration of the system is represented by the Substation Configuration Description (SCD) file. It contains substation description section, communication configuration section and all IEDs. The IEDs in the SCD file are not anymore in their default configuration, but as they are configured to operate within the substation protection and automation system. These files are then used to configure the individual IEDs in the system.

The Configured IED Description (CID) file represents a single IED section of the SCD file described above.

## FILE NAMING CONVENTION

The file naming convention defined in the IEEE C37.232 is a readable, delimited filename format. The delimiting character between the filename fields is the “,” comma. In all cases where an alphabetical character is called for, the character can be either upper or lower case. Software should treat upper and lower case letters in the same way. The fields for the filename shall be as follows and in order as shown here:

The standard defines a readable, comma delimited, text format. The file name includes the following required fields:

***Start Date, Start Time, Time Code, Station Identifier, Device Identifier, Company Name***

Additional fields may be added as needed by the user and are called “user fields”. The standard requires that the user fields follow directly after the required fields and in order:

***, User-1, User-2, User-3, User-4, and so on. Extension***

All required and user fields are separated by commas. Only one comma is used to separate between fields (trailing commas should not be used). The extension will always follow at the end as shown above.

## IED NAMING CONVENTION

A common naming convention for specifying IED designations would help solve many of the problems that are associated with the analysis of different electric power system events. That is why the IEEE PES Power System Relaying Committee understood the need for standardization of the IED names and started a working group – H10 - with the task to create a PSRC Report that describes a convention to uniquely identify (name) installed Intelligent Electronic Devices (IEDs) including measured and calculated quantities for the purpose of sharing data collected by these devices. The common convention will, in turn, have a positive impact on maintenance, protection, operations, and on engineering applications. To that extent, the main objective of the H10 working group is to address and report on the issues related to specifying IED designations. The report explains the need for having a common naming convention and provides a brief, high level, survey of current and best practices.

## CONCLUSIONS

The use of the different standard data formats and naming conventions allows the development of automatic fault analysis tools that will improve the quality of electric power systems event analysis and significantly reduce the required

time based on the elimination of the manual conversion of proprietary data formats.

This can be achieved only through the joint efforts of utilities, consultants and manufacturers, based on the numerous working group activities in IEEE, IEC and CIGRE.