

ADVANCED PROTECTION OF OVERHEAD LINES IN THE EVENT OF INTERRUPTED CONDUCTOR

Viktor LOVRENCIČ
C&G d.o.o. Ljubljana, Slovenia
E-mail: viktor.lovrencic@c-g.si

Zvonko TOROŠ
Elektro Primorska d.d., Slovenia
E-mail: zvonko.toros@elektro-primorska.si

Samo CEFERIN
Kolektor Sinabit d.o.o., Slovenia
E-mail: samo.ceferin@sinabit.si

Marjan BEZJAK
E-projekt d.o.o., Slovenia
E-mail: marjan@e-projekt.si

Benjamin TURNŠEK
Elektro Primorska d.d., Slovenia
E-mail: benjamin.turnsek@elektro-primorska.si

Bojan Likar
Kolektor Sinabit d.o.o., Slovenia
E-mail: bojan.likar@sinabit.si

Matej Dečman
C&G d.o.o. Ljubljana, Slovenia
E-mail: matej.decman@c-g.si

ABSTRACT

Broken semi-insulated conductors (often called downed covered conductors - CC) present increased risks for humans and animals that might come in contact with conductors under voltage. The solution is in the protection of broken conductors LiSa[®], which detects faults on the medium-voltage power network and substations. Protection of broken conductors LiSa[®] helps to ensure the safety of both producers as well as distributors of electricity. Described LiSa[®] solution is an integral part of the remote control systems of transformer stations MV/LV (Medium-Voltages/Low Voltages).

INTRODUCTION

There are more than 700 km of MV lines realized by covered conductors in Slovenia [1,2]. Due to improper installation, inadequate materials and frequent and active atmospheric discharging, frequent interruptions of conductors in such lines are known (some ten cases documented in the last years).

Generally, such interruptions of conductors are detected and eliminated from the remaining part of healthy distribution power network by means of classic current electrical protection.

But there are cases when standard ground current protection is unsuccessful. This happens when interruption of the conductor does not cause grounding current or the current is too small to be detected. There are several reasons for this, such as interrupted conductor not in contact with soil (because of insulation on the conductor), or very poor contact with soil (rocky or sandy terrain), therefore the electrical resistance on the contact point is very high (high-resistance fault), or specific configuration of the power network (long lines or different earthing systems or non earthing grid), or some other failure current, which in

breaking of the conductor does not start the earth current or is not large enough to activate earth protection.

In all of these cases, interrupted conductor on which the voltage is present, represents a high risk of death or of a serious injury until failure is detected and overhead line is switched off. The action of switching off of the overhead line can take a few hours or in exceptional cases even several days.

The issue of unidentified interrupted under-voltage conductors, which caused a lot of distress between academic circles in recent years in Slovenia, is particularly the covered conductors in MV overhead lines. Therefore, the authors of this article devote their attention on the research of protective devices disclosing interrupted conductors so that the overhead line would be switched off, accordingly.

In face of the issue of unidentified interrupted under-voltage conductors the Association of Slovenian electricity distribution in 2004 introduced a moratorium on the construction of the power network with semi-insulated conductors, until there is a comprehensive study to investigate the consequences of intermittent semi-insulated conductors with directions for the further construction available. In this sense, the authors of this article devote their attention on the research of protective devices which would disclose interrupted conductors and the switch off overhead line, accordingly.

In 2006 [3], the distribution utility company Elektro Primorska d.d. decided to equip some parts of MV power network in order to be protected against the danger of interrupted overhead lines with covered conductors with the patented system LiSa[®] – a system for detection and disconnection of an interrupted covered conductor(s).

It is required that the system includes additional devices (measuring points), thus the electrical protection system LiSa[®], by measuring asymmetry of the three-phase system,

detects downed conductors.

I. DESCRIPTION OF THE SYSTEM LiSa[®]

Measuring of secondary, low voltage (LV), in transformer station (TS) MV/LV with the appropriate network analyser only gives the information about unidentified failure(s), which can be fuse failure (s), break of conductor, power failure on the TS or power failure throughout the MV line as a result of some other failure. It does not give us unambiguous information about downed conductor(s).

For unambiguous information of the broken conductor(s) we need information from the primary side of the transformer. The system allows the reception and processing of information from the primary and secondary sides and using these signals failures (broken MV conductor, MV fuse failure, operation of transformer protection, etc.) are detected and analysed. That method unquestionably establishes that the conductor(s) which are broken must be switched off directly or indirectly through RCC (Remote Control Centre).

According to the patent SI21717 and EP 2 109 205 A1 [4], the system LiSa[®] detects and identifies the location of broken conductors of all types, including bare conductors, at all voltage levels, by placing the detectors in the line, as shown in Figure 1: Allocations of detectors.

Indicator or detector can directly or indirectly, through RCC, switch off line(s) or inform about failure RCC and/or an electrician on duty, informing the maintenance group about failure, which then determines the type and location of the damage and necessary repair works to solve the failure. The important thing is not how detector is carried out, it is moreover its functional structure, which must meet the requirements of detection and the Slovenian patent SI21717 and European patent EP 2 109 205 A1 [4].

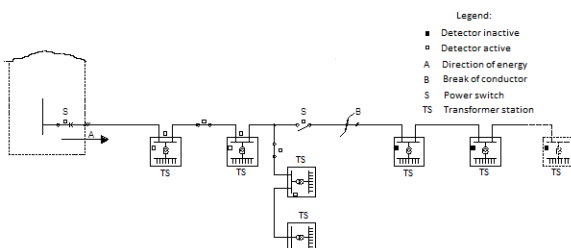

Figure 1: Allocations of detectors

The concept of the system is:

- voltage measurement in points of distribution power network;
- aggregation of data on the level of RTU unit transmission of data through telecommunication channels to concentrator device;

- processing of transmitted data from the measuring points in the power network and comparison of the values in algorithm;
- the algorithm determines the status of the power network;
- transmission of alarm in RCC, SMS message to the responsible personnel;
- remote switch-off of faulty line.

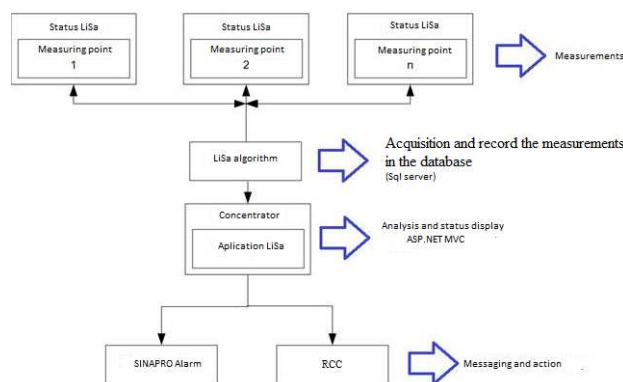

Figure 2: Concept of the system LiSa[®]

II. CONTROL SYSTEM

Control system consists of several individual components:

1. Central location

The central location is the server software with implemented software packages for data transfer, with implemented algorithm of protection, and analysis of measurement and alerting or messaging.

1.1. Concentrator device

Application for capturing, for storing of data in a central database as well for downloading and connecting to existing applications (RCC, PQ).

Application contains information from remote locations periodically covered and stored in a database on the server while data is available for the use of various investor services and activities. It also checks and indicates the status of objects. In the event of an alarm condition on the object, data from the object is immediately transferred to the centre. Information about security and operational parameters is transferred to distribution system management centre (RCC) through the links according to the protocol IEC 60870-5-104. In the opposite direction (from RCC to remote locations), and through the same protocol, parameters and commands for the statuses of equipment are transferred.

1.2. Application of LiSa[®]

The basic functionality of the application is the detection of errors/failures on medium-voltage power network and transformer stations, signalling the detected errors and the implementation of automatic disconnection in case of detection of broken semi-insulated overhead lines. Fault detection algorithms are carried out under all possible operating conditions, taking into consideration the possibility of damages and known topology of medium voltage power network. On the SCADA system (RCC), LiSa[®] system will release only critical detected failures, which are not detected by any other electrical protection.

1.3. SINAPRO Alarm

The server application also has integrated Sinapro@Alarm, with implemented SMS email alarm for notification of personnel about faults detected on the system.

1.4. MiSMART

Application for storing and analysing of the measured data collected in remote objects. Review and analysis of acquired data users performed through MiSMART online clients.

2. RTU unit

RTU unit provides the following:

- data acquisition and management of measuring centres and other intelligent devices optional on-site through the communication device connections (RS232, RS485, Ethernet);
- signal data acquisition and control devices via auxiliary/signal contacts or device interface (state switching and protection devices, analogue capture of measurements - on/off devices, etc.);
- a unified control of all sub-assemblies included for different functionalities, such as monitoring security of supply, measurement of voltage quality, monitoring of operating parameters, control management, etc.;
- local recording of all covered states, measurements and events, equipped with time-tags for the transfer to the control centre(RCC);
- implementation of local data processed and managed on the basis of implemented algorithms and parameters transmitted from the control centre.

2.1. Measuring centres MC760(L), MC740L, MC330

For the measuring of characteristics of electrical energy and quality of voltage on each section, the measurement centre MC760, MC330 on part of LV power network, is intended. In case of need for measurements on the MV part or other sections on the location, it is possible to expand configuration with additional measuring centres - the choice

depending on the required functionality of measurements.

3. COMMUNICATIONS

3.1. Telecommunication channel UMTS/HSDPA/GPRS

To link all objects included in the project, there is the connection to the central office via GPRS/UMTS wireless connection available. It is also possible to use and expand the system with the use of other available telecommunications networks (e.g. fibre connectivity, xDSL wired connection, etc.) Devices installed on the local side are connected to the telecommunication router through a single Ethernet bus with following subsets objects:

- measuring centres;
- universal RTU unit;
- AMI concentrators.

3.2. Protocol for data transmission RTU <-> concentrator

Protocol for data transfer between the RTU and concentrator is based on UDP/IP protocol and Modbus RTU protocol.

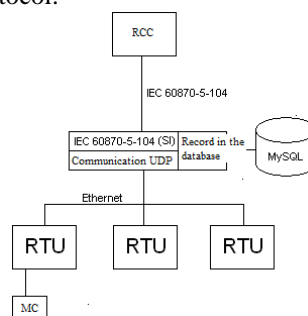

Figure 3: Protocol RTU <-> concentrator

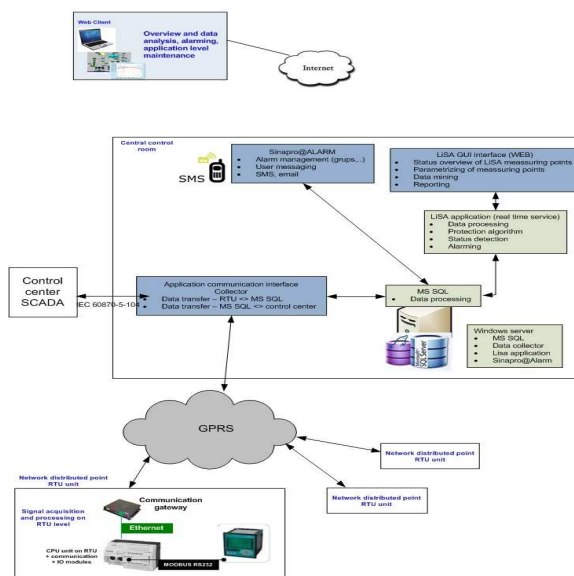

Figure 4: Overview of the system

4. MEASURING POINT

The following control, measurement and communication equipment is installed at measuring points:

- RTU unit;
- measuring control centre unit (MCxxx);
- telecommunication router;
- other necessary equipment for the operation (UPS, clamps, heater, ...).



Figure 5: Cabinet with all system equipment

5. GRAPHIC INTERFACE APPLICATION

By means of graphic interface applications we can monitor real conditions on objects where the LiSa[®] system is installed. Besides the monitoring via the interface, it is also possible to set the parameters of the system (naming of measurement points, set a value of protection ...).

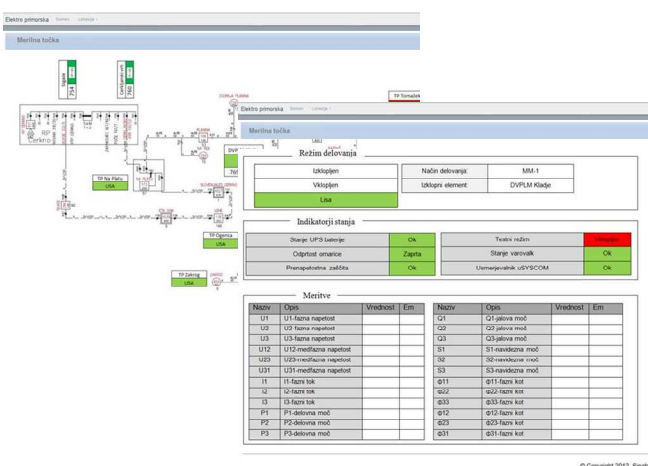

Figure 6: Graphic interface application

IV. CONCLUSION

The problem of unidentified downed conductors did not arise as late as in the last years. It has been present throughout the history of electric power lines. On many lines, even on those with bare conductors, and at all voltage levels, regular interruptions of conductors appear and often

these cannot be detected by standard electrical protection.

The technical solution for electrical protection LiSa[®] introduces new technologies of wireless/mobile telecommunication technologies, which are exercised in our electricity power networks, thus has become an integral part of the system of quality control of electrical power, remote measurement of electricity and management and remote control of distribution power networks. Therefore, the proposed solution of protection is in accordance with the winning concepts of the development of the power system used for all kinds of lines, at all voltage levels, where existing protection cannot detect downed conductor(s), cannot localize defects and cannot turn off faulty lines.

LiSa[®] system is an upgrade of earth-current protection; it works on the same switches as appropriate earth-current protection. LiSa[®] system can be more selective, with the possibility of determining the location of the failures.

LiSa[®] system for detection and timely switch-off of lines with interrupted conductors is an effective, safe and affordable system, and will become an integral part of the system of each power line where existing protection cannot find downed conductors and therefore faulty conductor are not switched off.

Up to now, this system for detection and disconnection of downed conductor has been installed on four overhead lines. At the project start, the system only signalled the alarm, but from 2012 onward, the system works as protection with disconnection of faulty overhead line. The system is also used for measuring of power quality (according to the standard EN 50160) and for alerting/communicating of events. The system's operation is most reliable and detects defects or downed conductors.

V. REFERENCES

- [1] V. Lovrenčič, Slovene experience on using covered conductors (PAS system) in medium voltage network, Processings China International Conference on Electricity Distribution (CIRED 2000), Shanghai, 17.-20.10.2000
- [2] T. Leskinen, V. Lovrenčič, Finnish and Slovene experience on covered conductor overhead lines, Processings CIGRE Session 30, Group B2, Paper B2-207, Paris, 23. – 27.8.2004
- [3] V. Lovrenčič, Z. Dimović, S. Peulić, Naprava za odkrivanje in izklop voda s prekinjenimi vodniki – primer pilotske instalacije na Elektro Primorska, Processings SLO CIGRE, Čatež, maj 2007
- [4] European patent EP 2 109 205 A1: Remote operation control of MV/LV transformer station and remote signalling of faults