

TOWARDS DISTRIBUTION ENERGY MANAGEMENT SYSTEMS: MAXIMISING RENEWABLE DG

Sahban W ALNASER

The University of Manchester – UK
sahban.alnaser@postgrad.manchester.ac.uk

Luis F OCHOA

The University of Manchester – UK
luis_ochoa@ieee.org

ABSTRACT

Actively managing network constraints in real time may allow Distribution Network Operators (DNOs) to connect greater volumes of renewable Distributed Generation (DG) without the need of expensive reinforcements. Here, a distribution Energy Management System (EMS) is proposed to manage voltages and congestion issues whilst allowing maximum harvesting of renewable resources. This is based on the optimal control of voltage regulation devices and DG power factor, applying DG curtailment as last resort. The proposed EMS is applied to a real-life UK MV network from the North West of England. Results show that effectiveness of the approach in managing the network within voltage and thermal limits whilst minimizing DG curtailment.

INTRODUCTION

Increasing levels of renewable Distributed Generation (DG) on traditionally passive distribution network pose significant technical and economic challenges to Distribution Network Operators (DNOs). In particular, the variability of wind generation and its non-coincidental pattern with demand may create a reverse current flowing upstream that cause a deviation in the voltage levels above statutory limits and exceed thermal capabilities of assets. To tackle these issues, most DNOs limit firm generation (i.e., free to generate up to nominal capacity) connections considering the worst case condition, i.e., max generation and min demand. This, in most cases, rarely occurs when dealing with wind power. Such a "fit and forget" approach restricts future DG connections and triggers network reinforcements (to be paid fully or partly by DG developers). Consequently, to effectively integrate more renewable DG a more intelligent management of the network is required.

Government targets and the regulatory framework in the UK require DNOs to facilitate the connection of greater volumes of DG. In addition, incentives exist to defer the capital expenditure (i.e., network reinforcements) when technically possible [1] and to promote new operational strategies [2]. Consequently, DNOs are encouraged to explore cost-effective solutions for the connection of DG. Indeed, in the last few years, a few DNOs have implemented Active Network Management (ANM) schemes to actively control the real power output of wind turbines and curtail their power production to reach acceptable network operating margins [3].

Although energy harvesting is not of interest to DNOs in countries with unbundling rules, DG curtailment should

be restricted as much as possible to accelerate the transition to a low carbon economy (i.e., allowing more cost-effective connections). For this, network elements such as on-load tap changers (OLTCs) and the DG plants themselves (power factor and curtailment) can be optimally controlled in order to manage potential voltage and congestion issues [4].

This work presents a comprehensive distribution Energy Management System (EMS) platform aimed at managing network constraints (i.e., voltage rise and thermal overloads) whilst maximising energy harvesting (or minimising curtailment) from renewable wind sources. A centralised AC Optimal Power Flow (OPF) (i.e., a non-linear programming problem) to produce the optimal set points for the active elements is adopted [4]. This AC OPF is tailored to comply with the existing connection agreements that might allow some DG plants to deliver power up to its rated capacity (i.e., firm connections), and to cater for normal (locally controlled) OLTCs.

DISTRIBUTION EMS

The proposed distribution EMS platform is shown in Fig. 1. Pseudo real-time measurements, to be in practice managed by a SCADA system, are obtained from time-series simulations run by a distribution network modelled in OpenDSS [5]. Network elements are monitored each control cycle in order to identify branches (i.e., lines or transformers) exceeding the thermal loading threshold or nodes with voltages beyond the voltage threshold limits.

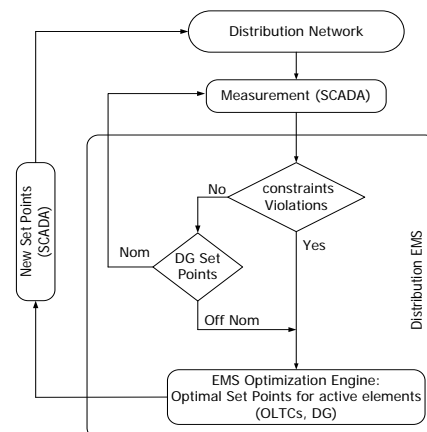

Fig 1. Architecture of the proposed Distribution EMS.

The AC OPF-based optimisation engine of the EMS, implemented in the modelling language AIMMS [6],

finds the best set points for the available controllable resources (i.e., OLTCs, DG power factor, and DG curtailment) upon the violation of constraints (or the existence of curtailment). These new set points will be used throughout the following control cycle. As a proxy of minimizing DG curtailment, the AC OPF formulation has an objective to maximise the total active power of the controllable DG plants (set G , indexed by g),

(1)

CASE STUDY: REAL-LIFE MV NETWORK

The proposed distribution EMS is applied to a real-life UK MV network from the North West of England in order to assess its effectiveness in managing DG.

Test Network

The electrical network characteristics are modelled in OpenDSS. The single line representation of the network is given in Fig 2. The 33kV-feeders of the test network are supplied by two 63MVA 132/33kV power transformers at the Bulk Supply Point (BSP). The voltage of the 33kV system is regulated by the OLTCs in the BSP using the regulation range of +10% to -20%, in 18 steps of 1.67% with a voltage deadband setting of $\pm 2\%$ and a time delay of 90s. Similarly, the primary substations 33/11kV are equipped with OLTCs with a pre-defined target of 1.0 p.u. at the 11kV terminal. The regulation range for the OLTCs in the primaries is -17.16% to $+5.72\%$ in 16 steps of a step of 1.43% using a deadband of $\pm 1.5\%$ and a time delay of 120s.

The load profiles for the aggregated loads at the primary substations are based on the corresponding annual peak demand and the number and type of customers (e.g., domestic unrestricted, domestic with two tariff rates, small non-domestic). Half-hourly profiles for each customer type based on ENWL customer base are adopted. The maximum and the minimum demands for the whole network are 31 and 15 MW, respectively.

The network accommodates four DG plants with firm connection agreements at buses 201, 206, 207 and 209 with capacities of 9.1, 10.6, 7.5 and 12MW, respectively.

The multi-period AC optimal power flow planning tool developed in [4] is applied to this network in order to calculate the maximum additional DG capacity that can be connected (same locations of the existing DG) considering the ideal operation of a range of ANM schemes: coordination of OLTCs, DG power factor control, and DG curtailment. It was found that an extra 52MW could be connected to the network (with capacities of 4, 6.5, 15, and 26.5 MW at the buses 201, 206, 207, and 209, respectively). Given that the planning tool neglects the actual real-time operational aspects of the ANM schemes, these values will test the performance of the proposed distribution EMS.

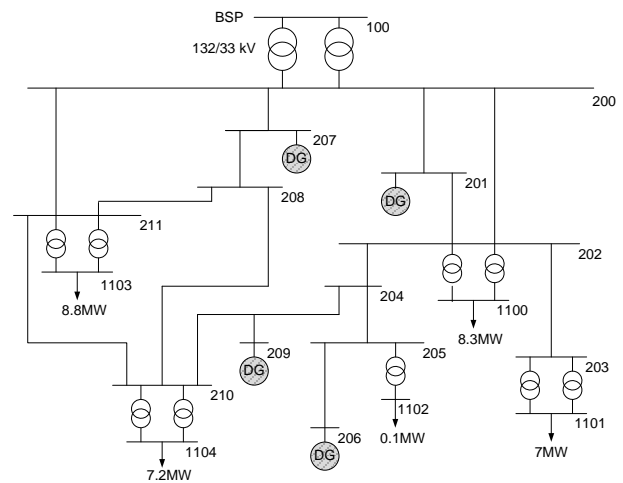

Fig 2. Real-life UK MV network from the North West of England.

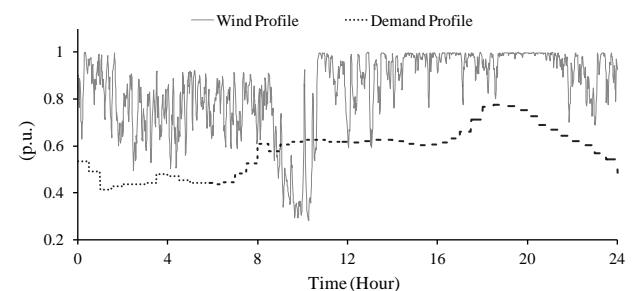

Fig 3. Normalised wind and demand profiles on 1st February 2010.

All the generators are considered to be capable of operating with power factors between 0.95 inductive and capacitive. It is assumed that all the DG (firm and the new) in the network has the same wind resource. The normalised demand and wind profiles for 1st February 2010 are shown in Fig. 3.

Business as Usual Operation

To examine the benefits from the proposed distribution EMS in managing network constraints, the business as usual operation (i.e., no active management) is compared with different active network solutions. Given that simulations are carried out with one minute resolution, the analyzed period is limited to one day of the first week of February 2010.

Without control, the wind farms create a significant reverse power flow through the lines in the network during minimum demand. The maximum thermal violations occur at line 200-201, exceeding its thermal limit (17 MVA) by 21%. In addition, the voltage at bus 205 exceeds the statutory upper limit of 6%, reaching 1.09 p.u. The voltage excursions at this bus occur during

23% of the analysed week which clearly shows that the voltage profiles do not comply with the European standard EN50160. This standard states that during an observation period of a week, 95% of the voltage magnitude measurements should be within the statutory limits of, in this case, $\pm 6\%$ [7]. It should be mentioned that in this work the performance of the network against the standard considers 1-minute measurements instead of 10-minute averages.

Curtailed only EMS

Here, the proposed AC OPF-based distribution EMS is continuously monitoring network elements and controlling (if necessary) the output of DG plants every five minutes. The voltage thresholds is set to 90% below the upper voltage limit (1.054 p.u.) as well as the line-flow threshold is set to 90% of the thermal capacity of the network elements (i.e., transformers and lines). When the measured values exceed these thresholds, control scheme is initiated and corrective action is applied. Control cycles are every 5 minutes. To illustrate the operation of the curtailment-only EMS, the loading of line 200-201, the voltage profile at bus 205 and the set points of three wind farms (that affect the loading of the line 200-201) are all shown in Fig. 4 for the same hour in February.

It can be seen that in minute 1, the controller is activated to solve for thermal issue. Based on the optimisation engine, the EMS sends a control signal to the wind farms in order to pitch the turbines' blades in a way that the set points are now 57%, 51% for the wind farms 201 and 206, respectively. Although this setting will be kept until the next control cycle, the one-minute resolution simulations show the corresponding response. At minute 5 there is no constraint violation, thus the EMS triggers the optimisation to find new set points to maximise the total active power of the controllable DG units given that curtailment has been applied to the wind farms. The total output of the DG plants is indeed partially improved at minute 6 by 1.3MW. In minute 15, the EMS reacts to voltage issue at bus 205 and deeply ramp down the set point for DG at bus 206 to a level of 29%. This process of monitoring and updating the wind farm's set point accordingly is carried out at each control cycle.

With EMS-curtailment scheme, the voltage profile at bus 205 maintains within the statutory limits for 99.99% of the time and complies with the EN50160 standard.

Full EMS

The active management of the OLTC in the BSP and the power factor of the wind farms can alleviate voltage excursions and decrease the use of curtailment. It can be seen from Fig 5 that the taps of the OLTC are increased and the wind farm at bus 206 operates at inductive power factor (mostly close to 0.95) in order to minimise curtailment whilst maintaining the voltage at bus 205

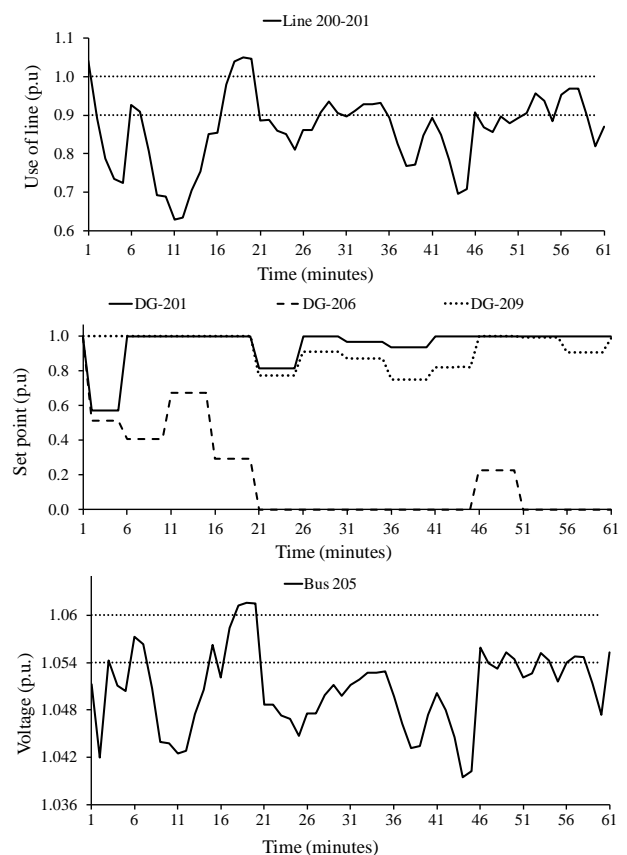

Fig 4. Curtailed only EMS. (Top) Use of line 200-201 p.u., (middle) Voltage profile at bus 205 p.u. and (bottom) set points of DG 201, 206 and 209.

below the upper statutory limit. Crucially, the DG at bus 206 is given a set point around 25% during the minutes 22-44 allowing power injection instead of being fully curtailed as happened in the previous case (Curtailment Only EMS). For instance, in minute 21 the tap in the BSP is increased to 1.0501 and the power factor is set to -0.95 inductive and the DG is given a set point of 17%.

It can be observed that at minute 45, the optimiser decides to raise the wind farm's set point based on the voltage and the use of the line (within limits). However, in the next minute the wind speed increases resulting in thermal issues beyond the limit. This error is due to the adopted persistence forecasting model which considers that the wind resource and demand remain the same from one cycle to the next one.

The use of shorter control cycles allow closely following wind variability and most likely preventing the impacts of substantial changes in generation. This is can be clearly seen in Fig 6 with the power flow profile in line 200-201 when applying a control cycle of 1-minute. However, it should be mentioned that the granularity of monitoring and the actual control response are limited by the time

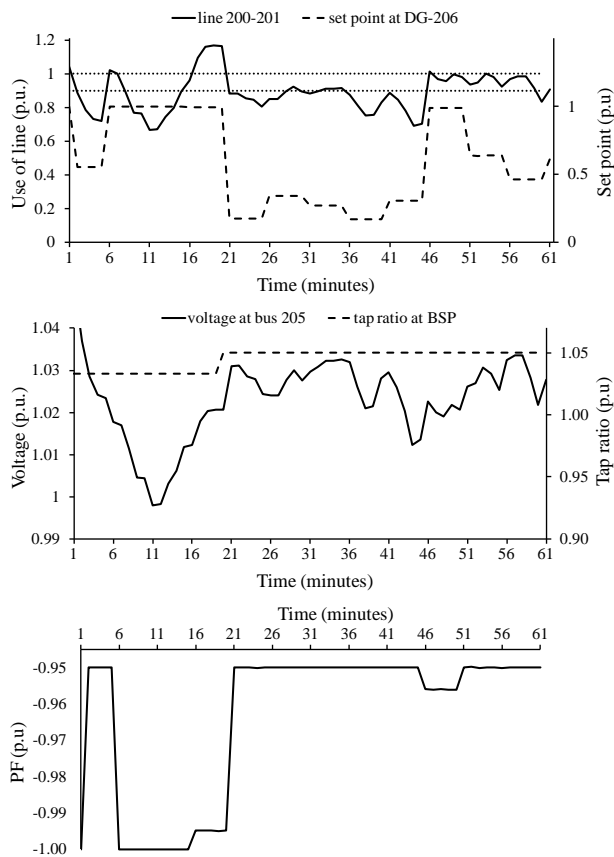

Fig 5. Full EMS. (Top) Use of line 200-201 and set point for DG 206, (middle) voltage profile at bus 205 and tap ratio at BSP, and (bottom) reactive power for DG 206.

requirements of the data acquisition processes, the optimisation engine, and the communication channels.

Energy Harvesting

For the first week of February 2010, the application of the full EMS leads to 2.87 GWh of production, which is 6.7% above the curtailment scheme alone.

CONCLUSIONS

The proposed Distribution EMS is applied to a real-life UK MV network from the North West of England considering multiple generators and OLTCs. The results show that the thermal and voltage constraints in the network are effectively managed in real time and high volume of DG capacity can be connected to the network. The active management of OLTCs and DG power factor can alleviate voltage rise issues and minimise energy curtailment. The benefit of adopting higher sampling rate in the proposed EMS in order to closely follow the network behaviour is presented. This work will be developed to cater for the uncertainties in the wind profile and with applying different control cycles.

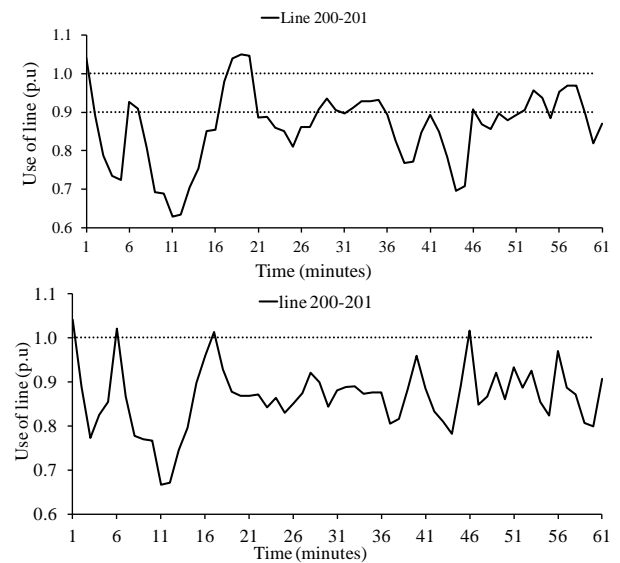

Fig 6. Use of line 200-201 p.u. after applying the full EMS with (top) 5 minute and (bottom) 1 minute control cycles.

REFERENCES

- [1] Office of Gas and Electricity Markets (Ofgem), "Electricity distribution price control review - Final proposals - Incentives and Obligations," Dec. 2009.
- [2] Office of Gas and Electricity Markets (Ofgem), "Low Carbon Networks Fund Governance Document v.1," Apr. 2010.
- [3] R.A.F. Currie, G.W. Ault, C.E.T. Foote, and J.R. McDonald, 2007, "Active power-flow management utilising operating margins for the increased connection of distributed generation", *IET Proceedings Generation, Transmission & Distribution*. vol. 1, 197-202.
- [4] L.F. Ochoa, C. Dent, and G.P. Harrison, 2010, "Distribution network capacity assessment: Variable DG and active networks", *IEEE Trans. on Power Systems*. vol. 25, 87-95.
- [5] Open Distribution System Simulator - OpenDSS. [Online]. Available: <http://sourceforge.net/apps/mediawiki/electricdss>
- [6] J. Bisschop and M. Roelofs, "AIMMS - The user's guide," *Paragon Decision Technology*, 2006.
- [7] UK Department of Trade and Industry, *The electricity supply, quality and continuity regulations 2002*, Sep. 2002.