

## IMPACT OF VOLTAGE PHASE ANGLE CHANGES ON LOW-VOLTAGE RIDE-THROUGH PERFORMANCE OF SMALL SCALE HYDRO DG UNITS

Trond TOFTEVAAG  
SINTEF Energy Research – Norway  
trond.toftevaag@sintef.no

Traian-Nicolae PREDA  
NTNU, Trondheim – Norway  
traian.preda@elkraft.ntnu.no

Kjetil UHLEN  
NTNU, Trondheim – Norway  
Kjetil.Uhlen@ntnu.no

### ABSTRACT

*Computer simulations of a simplified radial 132, 66 and 22 kV system including a 5 MVA hydro power unit, has been performed in order to assess the hydro unit's fault-ride-through (FRT) capability, with special emphasis on the Critical Clearing Time (CCT) of the unit. The results show that there is a significant difference in CCT when the disturbance reflects a realistic fault in the system, i.e. a fault that reflects changes in both voltage magnitude and phase angle, compared with a disturbance for which only the change in voltage magnitude is taken into account. Since requirements regarding fault-ride-through (FRT) capability found in most of today's national grid codes are defined via a specified transient voltage vs. time disturbance profile, the paper therefore suggests that these requirements should be extended to include also corresponding phase angle vs. time disturbance profiles.*

### INTRODUCTION

Requirements regarding fault-ride-through (FRT) capability found in most of today's national grid codes are defined via a specified transient voltage vs. time disturbance profile, or more specifically via the change in amplitude of the voltage, for which the generation units are required to maintain production without interruption or shut-down. The corresponding voltage's phase angle change is not mentioned in these codes. This applies to grid codes for transmission system and regional grid level, medium-voltage distribution grid level, or both. As an example the latest version of the ENTSO-E "Network Code for Requirements for Grid Connection applicable to all Generators" (July 2012) do not specify requirements related to the voltage's phase angle change in this context, only change in voltage amplitude. [1]

Introductory analyses indicates that the voltage' phase angle might have significant influence on the dynamic behavior of typical small scale hydro DG units during a transient disturbance; see ref. [2] for further details. Ref. [2] describes the results from a computer based study in which a model of a typical radial MV distribution grid is established, including the superior regional grid and a small scale hydro unit (5 MVA) equipped with synchronous

generator which represents the study object of the work. The present work forms a direct follow-up of the work presented in ref. [2].

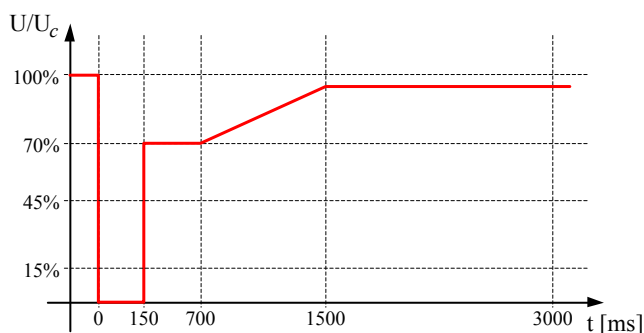
Manufacturers and/or developers of energy sources like small scale hydro DG units or wind turbine generators will have to prove the FRT capability of their units before permission for grid connection is given. As a first step the FRT capability for a given technology is often analyzed via computer based modeling and simulations during the planning process, in order to check whether the grid code requirements are met or not, and if not to establish a basis for improved solutions. In that context it is of course desirable that the basic conditions of the analysis, like the FRT capability requirements, are as realistic as possible.

The paper presents results from computer based FRT-capability dynamic simulation study for a typical hydro power DG-unit equipped with synchronous generator, for various specified fault related transient voltage profiles, with and without regard for the influence of the change in the voltage's phase angle during the faulted period. The critical clearing time (CCT) of the unit forms an important parameter of assessment here. The simulations are based on different parameter sets for the generator's excitation system. Two different faults locations are chosen for the model in question. Based on the results and discussion, recommendations for possible extension of existing network codes will be given.

### FAULT RIDE THOURGH REQUIREMENTS FOR DG UNITS

According to reference [3] FRT requirements are normally expressed via a voltage borderline of a voltage profile describing a temporary drop in voltage at the network connection point in relation to time. An example of such a borderline profile is found in Figure 1. According to [3] the DG unit should withstand a fault for which the voltage drop values should be above the specified border line, i.e. remain transient stable; otherwise the unit must not be disconnected from the grid. Generally as observed above, a FRT curve is representing the voltage dip experienced by a production unit when there is a fault somewhere in the grid. But as presented in [2], a grid fault creates a change in both voltage magnitude and voltage phase angle on the DG bus. So by decoupling these two quantities in separate ones

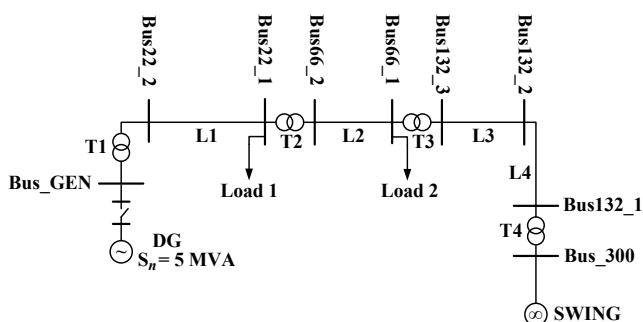
(voltage magnitude and angle) will give erroneous results when FRT studies for DG units are investigated. In the present research a continuation of the research produce in [2] is done, by stressing also what is the influence of considering the voltage phase angle variation on the CCT of the fault applied in the simplified model.



**Figure 1 Voltage magnitude against time profile for assessing FRT capability [3]**

**SIMULATION MODEL**

The same simulation model as used in [2] and depicted in Figure 2 is also used for the current work. The system consists of a simple 132 and 66 kV radial regional grid, a 22 kV high voltage distribution grid and a 300 kV "stiff grid" (swing bus). There are two loads in the system, at BUS22\_1 and BUS66\_1, respectively. The loads are modeled as constant impedance loads. The synchronous generator is connected to the 22 kV grid via a 0.69/22 kV transformer. Data for lines, transformers, loads and generator is given in Appendices 1, 2, 3, and 4.



**Figure 2 Single line diagram of system under study**

The synchronous generator model includes brushless excitation and two different models for automatic voltage regulator. The excitation system models are named Model 1 which corresponds to the IEEE AC8B type and Model 2 which is a modified version of an excitation system with DC commutator (but adopted for brushless excitation), described in Ref. [4] and [5]. Macro-blocks and data for the excitation system are given in Appendices 5 a) and b). As in

previous work, the generator is operated with constant mechanical torque for all of the dynamic simulation cases studied, i.e. no turbine/governor model is included.

**APPROACH, CASES AND RESULTS**

The approach is to first apply a fault in the grid model with a duration that reflects the CCT of the small hydro unit via trial-error method. Separate time series are recorded for the voltage magnitude and the phase angle of the DG bus. These recorded time series are used as input to new simulations where the grid is replaced with a voltage source with controllable voltage magnitude and phase angle on the DG bus. In this way separate simulations with change only in voltage magnitude and only in voltage phase angle can be run, and corresponding DG-responses can be recorded.

In the present research, the following four main cases have been investigated:

Table I. Study cases

Study cases	Fault applied at Bus:	Excitation System Model
Case 1A	Bus66_1	Model 1
Case 1B	Bus66_1	Model 2
Case 2A	Bus22_2	Model 1
Case 2B	Bus22_2	Model 2

In all four study cases, a 3-phase symmetrical fault with a resistive character (transition resistance of 1.9 Ω) is applied at t=1 s of the dynamic simulations. For all four cases, the power set point of the generator (S<sub>N</sub>=5 MVA) is 4 MW and 0 MVar for all cases.

Modelling and simulations of the system under study have been performed in SIMPOW<sup>®</sup> [5]. Selected results from the dynamic simulations are given in the following section.

**Results**

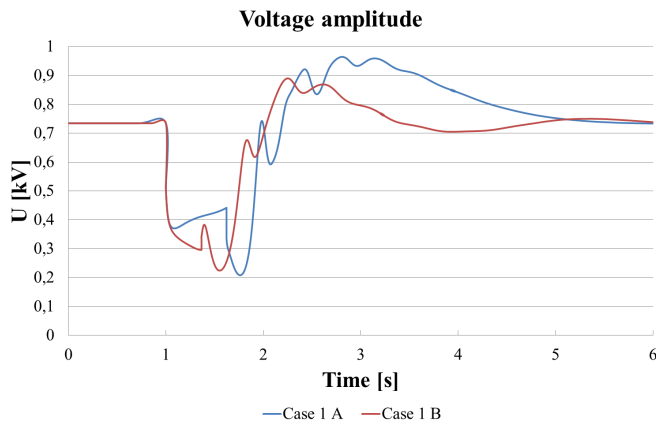
The following values for the CCT has been obtained from the simulation of the above study cases:

Table II. Critical clearing time [ms] for considered study cases

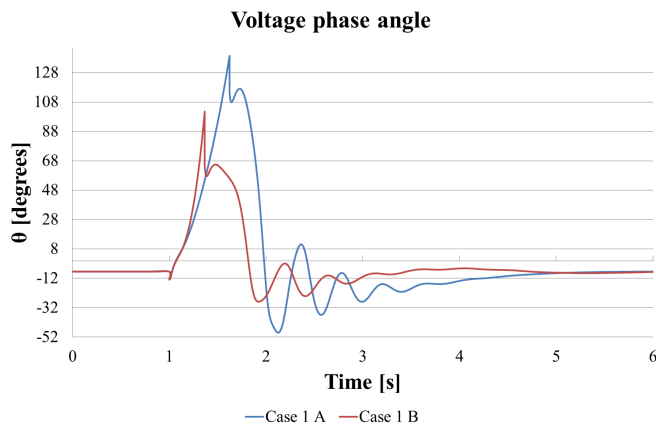
Study cases	CCT [ms]
Case 1A	623
Case 1B	366
Case 2A	313
Case 2B	272

**Voltage amplitude and phase angle**

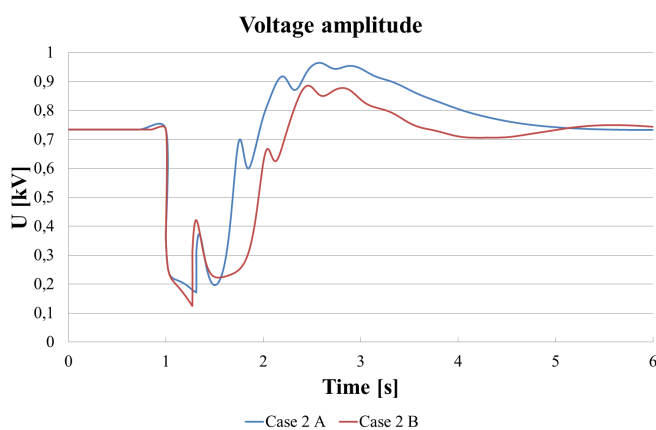
The change in voltage amplitude in relation to time on the generator bus, Bus\_GEN, as a result of the faults applied under Case 1A and Case 1B, respectively, is shown in Figure 3. The corresponding change in voltage phase angle is given in Figure 4.



**Figure 3 Voltage amplitude on generator bus (Bus\_GEN) for Case 1A and Case 1B.**

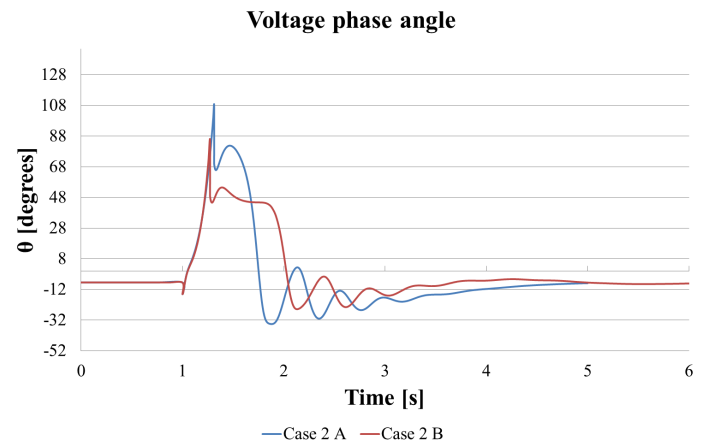


**Figure 4 Voltage phase angle on generator bus (Bus\_GEN) for Case 1A and Case 1B.**



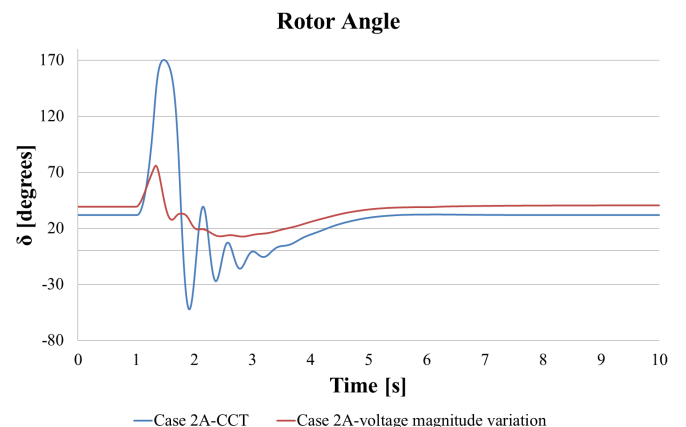
**Figure 5 Voltage amplitude on generator bus (Bus\_GEN) for Case 2A and Case 2B.**

Figures 5 and 6 present the changes in voltage amplitude and phase angle, respectively for Case 2A and Case 2B.



**Figure 6 Voltage phase angle on generator bus (Bus\_GEN) for Case 2A and Case 2B.**

As expected a significant change in the voltage phase angle can be observed from Figures 4 and 6 for these cases.



**Figure 7 Rotor angle variations for Case 2A - full model and defined voltage magnitude vs time profile. See text for further details.**

Figure 7 shows the plot of rotor angle versus time for the small hydro unit for a fault corresponding to case 2A, where the blue curve corresponds to the CCT calculation for the full grid model, and the second one corresponds to the case where the grid is replaced with a voltage source emulates only the voltage magnitude versus time variation from Case 2A, applied at the DG bus.

**DISCUSSION**

The present clearly shows that for a given disturbance the transient response of a hydro power DG-unit equipped with a synchronous generator strongly depends on both change in amplitude and phase angle of the terminal voltage caused by the disturbance. In addition the study shows that the type (and parameterization) of the unit's automatic voltage controller in this case have a significant impact on the unit's

CCT. Also, we observe that by decoupling the magnitude and phase angle of voltage, there will be large differences in rotor angle excursions meaning that the appreciation of the transient stability margin is erroneous.

**CONCLUSIONS**

In this work authors continued a previous study regarding the impact of voltage phase angle on the dynamic behavior of a small hydro unit equipped with synchronous generator. The results show that the transient response of the unit after a grid fault depends both on change in amplitude and phase angle of the terminal voltage, as appreciated in the last work. It can be observed that by investigating the dynamic behavior of the DG unit at grid code specified voltage magnitude vs time profiles will lead to erroneous results in the FRT studies.

**REFERENCES**

- [1] ENTSO-E. ENTSO-E AISBL, 2012, *ENTSO-E Draft Network Code for Requirements for Grid Connection applicable to all Generators*, Brussels, Belgium.
- [2] Toftevaag, T., Marvik, J., Preda, Traian-Nicolae: *IMPACT OF VOLTAGE PHASE ANGLE CHANGES ON LOW-VOLTAGE RIDE-THROUGH PERFORMANCE OF DG-UNITS*. CIRED Workshop Lisbon 29-30 May 2012. Paper 329.
- [3] BDEW, June 2008, *Technical Guideline Generating Plants Connected to the medium-Voltage Network*, BDEW, Berlin, Germany, 130 pages.
- [4] IEEE Std 421.5, 2005, *IEEE Recommended practice for Excitation System Models for Power System Stability Studies*, IEEE, New York, USA.
- [5] STRI AB, 2004, *SIMPOW User Manual 11.0*, Copyright STRI AB 2004, revision date 2010-09-24. STRI AB, Västerås, Sweden.

**APPENDICES**

**APPENDIX 1. Line parameters**

NAME	R [Ω/km]	X [Ω/km]	B [μS/km]	Length [km]
L1	0.359	0.373	3.0756	25
L2	0.395	0.415	1.98	30
L3	0.098	0.398	2.8934	55.2
L4	0.098	0.398	2.8934	36.5

**APPENDIX 2. Transformer parameters**

NAME	S <sub>n</sub> [MVA]	U <sub>n,1</sub> [kV]	U <sub>n,2</sub> [kV]	ER12 [pu]	EX12 [pu]
T1	5	0.69	22.0	0.005	0.100
T2	50	129.0	67.0	0.005	0.125
T3	20	62.0	23.0	0.005	0.100
T4	70	290.0	135.0	0.005	0.125

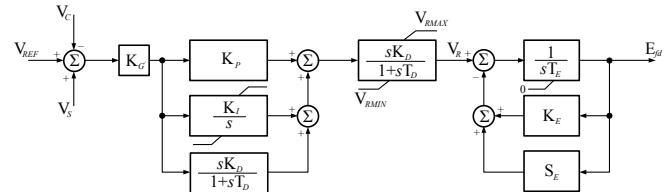
**APPENDIX 3. Load data**

NAME	P <sub>load</sub> [MW]	Q <sub>load</sub> [MVar]
Load 1	20	7.5
Load 2	16	4

**APPENDIX 4. DG model parameters**

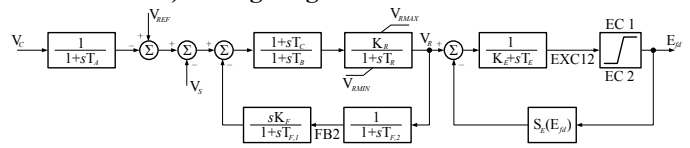
Parameter	DG model
X <sub>d</sub>	[pu] 2.04
X <sub>d</sub> '	[pu] 0.238
X <sub>d</sub> ''	[pu] 0.143
X <sub>q</sub>	[pu] 1.16
X <sub>q</sub> ''	[pu] 0.137
r <sub>a</sub>	[pu] 0.00219
X <sub>1</sub>	[pu] 0.13
T <sub>do</sub> '	[s] 2.38
T <sub>do</sub> ''	[s] 0.0117
T <sub>qo</sub> ''	[s] 0.11
H	[s] 1.0
V1D	[pu] 1.0
SE1D	[pu] 0.1
V2D	[pu] 1.2
SE2D	[pu] 0.3

**APPENDIX 5 a) Voltage regulator Model 1: IEEE AC8B Type**



Parameter	Description
K <sub>P</sub>	[pu] 120.5 PID proportional gain
K <sub>I</sub>	[pu] 165.5 PID integral gain
K <sub>D</sub>	[pu] 24 PID derivative gain
T <sub>D</sub>	[s] 0.01 PID derivative time constant
K <sub>A</sub>	[pu] 1.0 Voltage regulator gain
T <sub>A</sub>	[s] 0 Regulator time constant
V <sub>Rmax</sub>	[pu] 35 Maximum regulator output
V <sub>Rmin</sub>	[pu] 0 Minimum regulator output
K <sub>E</sub>	[pu] 1.0 Exciter constant
T <sub>E</sub>	[s] 0.5 Exciter time constant
S <sub>E1</sub>	[pu] 1.346 Saturation curve value at point 1
E <sub>1</sub>	[pu] 2.222 Voltage value at point 1
S <sub>E2</sub>	[pu] 1.9 Saturation curve value at point 2
E <sub>2</sub>	[pu] 2.962 Voltage value at point 2

**APPENDIX 5 b) Voltage regulator Model 2**



Parameter	Description
T <sub>A</sub>	[s] 0.05 Regulator amplifier time constant
T <sub>B</sub>	[s] 0.01 Time constant
T <sub>C</sub>	[s] 0.01 Time constant
K <sub>R</sub>	[pu] 500.0 Voltage transducer filter gain
T <sub>R</sub>	[s] 0.10 Voltage transducer filter time constant
K <sub>F</sub>	[pu] 0.04 Regulator stabilizing circuit gain
T <sub>F,1</sub>	[s] 0.7 Regulator time constant 1
T <sub>F,2</sub>	[s] 0.05 Regulator time constant 2
V <sub>Rmax</sub>	[pu] 35 Maximum regulator output
V <sub>Rmin</sub>	[pu] 0 Minimum regulator output
K <sub>E</sub>	[pu] 0.8 Exciter constant
T <sub>E</sub>	[s] 0.4 Exciter time constant
S <sub>E1</sub>	[pu] 0.0 Saturation curve value at point 1
E <sub>1</sub>	[pu] 1.59 Voltage value at point 1
S <sub>E2</sub>	[pu] 0.0 Saturation curve value at point 2
E <sub>2</sub>	[pu] 2.12 Voltage value at point 2
EC <sub>1</sub>	[pu] 6.2 Limit-parameter for saturation 1
EC <sub>2</sub>	[pu] 0.01 Limit-parameter for saturation 2