

PRELIMINARY VERIFICATIONS FOR THE CONNECTION OF DER TO THE DISTRIBUTION NETWORK: THE DETERMINISTIC APPROACH OF ENEL DISTRIBUZIONE

Giulio CANEPONI
Enel Distribuzione S.p.A. – Italy
giulio.caneponi@enel.com

Domenico DI MARTINO
Enel Distribuzione S.p.A – Italy
domenico.dimartino-dd@enel.com

Fabio CAZZATO
Enel Distribuzione S.p.A – Italy
fabio.cazzato@enel.com

Antonio PANICO
Enel Distribuzione S.p.A. – Italy
antonio.panico3@enel.com

Marco DI CLERICO
Enel Distribuzione S.p.A – Italy
marco.diclerico@enel.com

ABSTRACT

The large amount of DER connected, and that are expected to be connected in the next years, to the distribution network, introduces new technical issues in the electrical system, due to possible unbalances between load and generation, leading to the risk of instability of the network frequency and intervention of the regulation services. As a result, according to the new scenario in Italy, the growing push toward small and medium-sized generation plants makes it necessary to revise and upgrade the criteria for the technical verifications, in accordance to the correct network planning.

The growth of DER connected and new connection requests, generally focused on small plants, have a strong influence not only on network operation criteria but also on network planning, for example in terms of complexity of the load forecast. For this reason it is good to check by specific calculation and simulation SW applications, in advance to the connection, if the new production facility involves issues related to overcoming the technological limitations of the electrical distribution network components.

INTRODUCTION

Preliminary verifications for the connection allow to assess the technical compatibility between the connection of the power plant on the network and criteria adopted on the distribution network operation, providing, by the analysis of the electrical calculations results, a support for the forecast of the network development in a medium and long term perspective. Therefore, the values of the parameters, that are used to perform the verifications, are chosen according to criteria of MV and LV network planning adopted by Enel Distribuzione in order to fulfill the demand (active and passive) and to maintain the quality of service imposed by the Italian Regulator and / or established by EN 50160 and Technical Standards CEI 0-16 and CEI 0-21.

The verifications concern the following aspects:

- the voltage variation in steady and transient state across the MV network, affected by the connection of the new generator;
- the transport capacity of the network;

- the calculation of short-circuit current and the thermal withstand value;
- breaking and making capacity, for LV protection selectivity of the MV network affected by the connection;
- the increase of the capacitive earth fault current (I_c) and its coordination with the compensation limits of the unified system of grounding neutral wire MV;
- other parameters related to quality of service and voltage (number and type of interruptions, disturbances in the network, voltage dips, etc..) for the only MV connections.

In the following, methods and strategies for the identification of DER connection solutions to LV and MV networks currently used by Enel Distribuzione are presented.

PRELIMINARY INFORMATIONS FOR THE EXECUTION OF TESTS

In general, the following information on DER are required for defining a connection solution:

- number, type and rated power generators to install, their primary source of power and contribution to short-circuit currents;
- the power requested by the producer to be injected on the point of connection;
- contractual power already available in the connection point if the plant is already connected, even if it is only an end user;
- technical characteristics of user's network.

User data are made available to the network operators by mean of the module sent for requiring the connection of the plant. It is also fundamental to detect the existing network to which it is assumed to connect DER and on which the technical analysis will be carried out.

According to Technical Standards, DER integration in the network must not create issues to users not only already connected, but also planned to be connected to. Therefore, technical analysis should be performed on a network in which planned works, loads and generators are already included. This is also important to avoid further verifications and re-plan of works already designed or even in progress.

The network to be analyzed includes the generating capacity already connected and that for which the

solution has been already established on the same network.

CONNECTION SCHEMES OF MV AND LV ACTIVE USERS

The identification of the scheme and the insertion point of the User's power plant to the distribution network is conducted by the DNO considering the opportunities of the placement related to the proximity of power lines, primary and secondary substations.

The main MV/LV connection schemes are:

on existing lines/substations (CS):

- by rigid tee joints;
- by branching from switching box;
- by connection to antennae in existing secondary substations.

In new substations (CS):

- by connection to antennae in newly installed secondary substations.

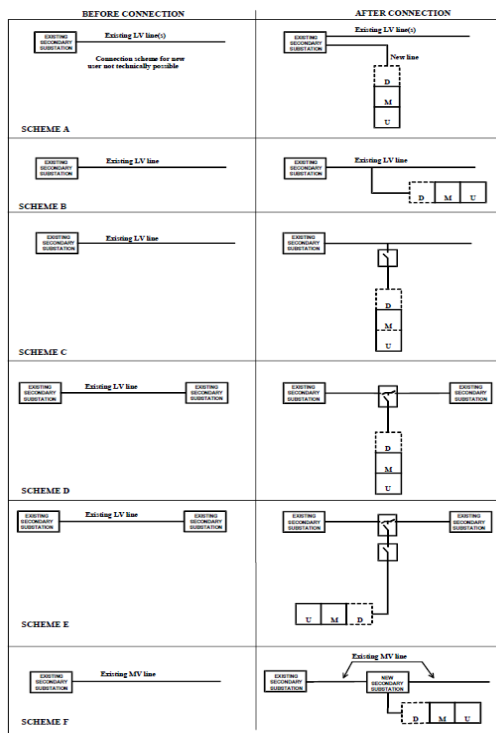

Figure 1. User installation connection schemes (by CEI 0-21).

The main HV/MV connection schemes are:

- rigid tee joints;
- incoming-outgoing;
- antennae.

The following figure shows the most commonly connection scheme used (Figure 2).

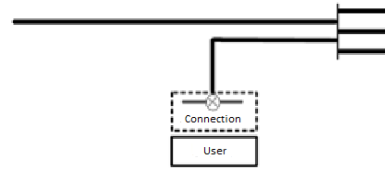

Figure 2. Connection by antennae (by CEI 0-16).

When needs to connect a user in a specific point of the distribution network, it's relevant to take into account if this point of the network is congested or not.

The "congested network" is defined as the network to which it isn't allowed connecting any power plant without providing upgrade actions on higher voltage networks.

When the MV network is congested, the connection of a new generator, both in MV and LV, is bound by the adaptation actions in both MV and in higher voltage networks (for example, new secondary substation, upgrade of MV line, new primary substation, upgrade of existing primary substation etc.).

For LV connections are specified two particular cases:

1. for domestic customers (new or existing), the connection solution indicated in the connection contract should not be bound by the upgrade actions of both MV and HV network;
2. for requests with power of the connection equal to 0, the connection solution indicated in the connection contract shall not be bound by the upgrade actions of the HV network.

In the presence of LV congested network, the connection solution for residential customers will be bound by the actions of the construction of new secondary substation.

CRITERIA FOR THE CHOICE OF THE TECHNICAL SOLUTION

The technical solution for the connection of DER to the network is usually defined, except for particular producer's claims, on the basis of a policy called "technical minimum", defined as "the solution for the connection of a user/producer such that the level of economic and technical works to be executed is less than other possible connection solutions. This solution may also include work on existing network. The technical minimum must also be technically feasible, achievable, able to accommodate the full power required by the user (except for those cases disciplined by Regulator's Acts), compatible with technical and operational standards in use. According to existing Technical Standards and Regulatory Acts, a minimum technical solution is identified on the basis of standard and healthy conditions of the network (N conditions). The figure below shows the logical scheme to identify the technical connection solution.

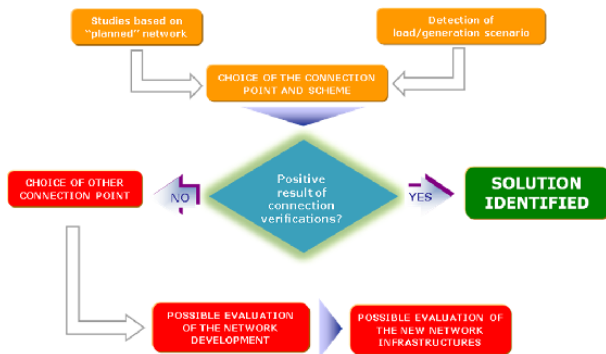

Figure 3. Logical scheme to identify the technical connection solution.

Voltage level of the connection

The current regulation in Italy defines power ranges on which the connection to a certain voltage level is mandatory:

- power required to be injected to the network ≤ 100 kW: LV network connection required;
- power required to be injected to the network ≤ 6000 kW: MV network connection required (except what stated before).

Between 100 and 200 kW, the choice of voltage level of connection (LV or MV), and between 6,000 and 10,000 kW (MV or HV), is operated by the DNO in accordance with his criteria.

Over or equal to 10000 kW (HV), the connection solution is operated by Terna (Italian TSO).

Particular prescriptions for the connection scheme in medium voltage

When identified an insertion point on the existing network, it must be defined how to connect DER and the network plant for the connection (derived from the line with or without disconnection devices, directly connected to an existing or new substation, in-and-out from the line). Factors affecting the choice are the distance of DER from the existing network, the network topology, its structure (overhead or underground) and its degree of automation. The choice must be made taking into account the planning criteria in use (Figure 4, Figure 5).

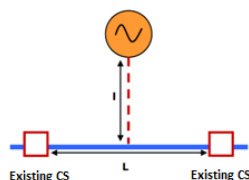

Figure 4. Case of generation plant close to the existing line

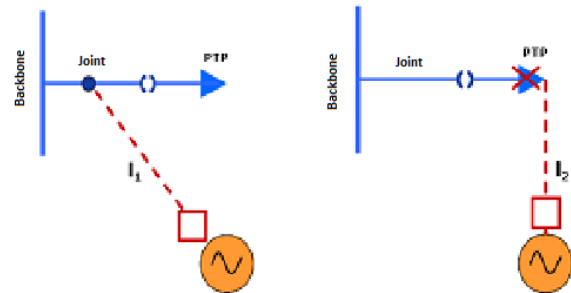

Figure 5. Case of generation plant close to a Pole-mounted Transformer.

Where there are a huge number of connection requests of nearby DER plants received in a limited time, it is desirable to choose the connection scheme considering all future facilities, expanding the concept of minimum technical solution to the whole system. In this way it is possible to plan the future network in a rational way.

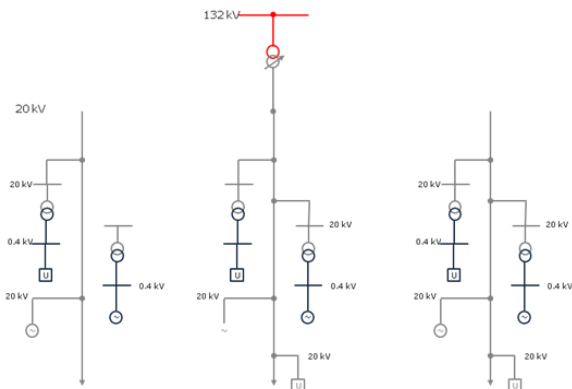

Figure 6. Graphic representation of the network considered in an example of the simulation.

Network developments

Together with the definition of the technical solution for a single DER plant, the possibility of identifying electricity network development works has been introduced, in order to promote its rational development and to improve the quality of service for all kind of users. In this category are included all those works that are not strictly required for connection of the DER but are consequential to their implementation in order to ensure optimum operation of the network even in fault conditions (N-1).

Example of development works: where a DER plant has to be connected to a MV feeder which already has more than 60% of its capacity in the worst conditions reserved for one or several generators to connect or already connected, realization of a new feeder joining the existing one as backup can make possible to properly operate the network even in faulty or N-1 conditions.

End of development works must not be a requirement for the activation of the DER.

FEASIBILITY STUDY

The analysis is needed to check if a given technical solution for the connection of DER is compatible with the network. It takes into account the following aspects:

- slow and rapid voltage changes across the network affected by the DER connection;
- network capacity;
- DER's contribution to fault currents;

The connection of the DER at a given point in the network is subject to the successful conclusion of all the test described below, performed with dedicated software.

TESTS ON VOLTAGE LEVELS

The purpose of these tests is to ensure that, following the insertion of DER, the voltage supplied to the network users involved and its variations are within the limits given by national and international Standards (EN 50160) and by connection agreement between DNO and users.

Since the voltage regulation strategies on the transformers are different between LV and MV networks, tests will be described separately.

Tests on MV network

Actual criteria for the voltage regulation based on the identification of a characterizing joint (the MV line which presents the greater voltage drop between all lines underlying the MV half-busbar) and on the minimization of the voltage irregularity.

The voltage stabilization to the network' nodes is done by the automatic voltage regulator (OLTC), which is installed on the primary side of the HV/MV transformer that , by varying the ratio of transformation, acting on the voltage of MV busbar. The regulation is exclusively made for the compensation current, which is a function of only the output current from the HV/MV transformer. The control parameters are mainly three:

- V_0 corresponds to the voltage on the MV busbars during no-load operation. This is the minimum voltage allowed;
- V_{max} is the maximum permissible level of voltage on the MV busbars;
- I_{comp} is the maximum value of current used in the regulation law. For values greater than or equal to I_{comp} , provided by the HV / MV transformer , the voltage on the MV busbar is V_{max} .

These parameters must be evaluated according to the physical characteristics of the underlying network and of loads. In practice, the evaluation requires a study for each HV/MV transformer.

The characteristic of the voltage regulator currently in use in Enel is this kind:

$$V_{sb} = V_0 + R_{comp} \cdot I_{trafo}$$

The compensation of the current is limited to the compound value. For greater values the OLTC keeps the voltage at the maximum value. So the I_{comp} represents the saturation value.

$$V_{max} = V_0 + R_{comp} \cdot I_{comp}$$

Where:

$$R_{comp} = \frac{V_{max} - V_0}{I_{comp}}$$

R_{comp} is measured in Ohm and represents the compensation constant (defined also compound resistance).

To simulate the operation of the OLTC is necessary to obtain the three compound parameters: V_0 , V_{max} and I_{comp} .

Data used to the calculation of these values are:

- programmed voltage (V_{p1}) [p.u.];
- coefficient of compensation (R_1 - R_2) [p.u.];
- maximum value of the compensation current (I_{max}) [p.u.];
- primary value of the TA's transformation ratio ($I_{max,TA}$) [A];
- nominal voltage value (V_n) [kV];

Acquired data input, compound values are calculated by a specific procedure which is shown in following steps.

The voltage on the MV busbar during the no-load operation (minimum value allowed of the voltage) is given by:

$$V_0 = V_n [kV] \cdot V_{p1} [p.u.]$$

To calculate the V_{max} or the maximum value allowed of the voltage on MV busbar, are obtained before the R_{comp} and I_{comp} :

$$R_{comp} = \frac{R_{1-2} [p.u.] \cdot V_n [V]}{I_{max,TA} [A]} \quad [\Omega]$$

$$I_{comp} = I_{max} [p.u.] \cdot I_{max,TA} [A] \quad [A]$$

$$V_{max} = V_0 [kV] + R_{comp} [\Omega] \cdot I_{comp} [kA] \quad [kV]$$

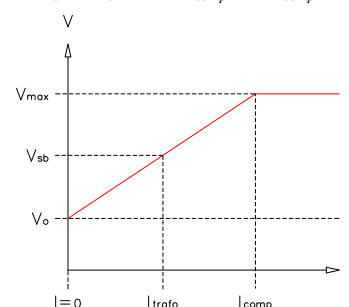

Figure 8. Graphic representation of the criterion of the voltage regulation by current compensation.

Connected DER decreases the current flowing through the HV/MV transformer: the voltage regulator understands it as a reduced passive load and drops the voltage on the MV busbar, affecting voltage profiles with the risk of going under the limit values, especially along feeders without DER underlying the same MV busbar.

Voltage tests check that these variations are within the range +/- 5% in order to ensure also that LV users underlying MV/LV nodes are supplied with a voltage respecting the limits. Furthermore, it is checked that the voltage on all MV nodes is within the range +/- 8% V_n in extreme network conditions (maximum and minimum load and the overall presence of DER).

With regard to the rapid voltage changes, in accordance with the new edition of EN 50160, voltage tests check that connection and disconnection of DER object of study does not cause voltage variations on all existing MV network nodes above the 6% V_n , without the OLTC to intervene.

Tests on LV Network

The voltage setting on the LV network is done using the voltage regulators placed on MV/LV. The transformation ratios can't be changed under load, so for the purpose of these analysis it is assumed a fixed transformation ratio.

For each node of the LV network, voltage tests check that the contribution of the generator is not likely to cause voltage variations greater than 8% V_n in extreme conditions of minimum load and maximum generation. This condition is simulated by placing the whole generation active, already present and planned, and loads values of 30% of their maximum calculated through the coefficient of utilization.

TESTS ON NETWORK CAPACITY

The energy flows caused by the presence of DER can exceed the thermal capacity of the conductors. The purpose of these tests is to check whether the contribution of DER to be connected is likely to exceed the following limits, as a percentage of the thermal limit current of the conductors: 80% on MV network in presence of generation and load; 100% MV with single generation network and 80% on LV network (if the LV network scheme provides the re-feeding, the percentage of the thermal limit current of conductors is 60%). These tests should be respected in all relative scenarios.

SATURATION OF HV/MV TRANSFORMERS

In areas of high concentration of DER (already installed and/or planned), it is possible that the power fed into the network itself is comparable to the rated power of transformers. Where the power flow through the transformer exceed the 90% of its rated power, it is needed to upgrade existing transformations (e.g. through

the replacement of transformers with other higher-size) or even the construction of new primary or secondary substations. The alert level is fixed in 65% of rated power. Where works at higher voltage levels are needed, the network is defined as congested.

TESTS ON DER'S CONTRIBUTION TO FAULT CURRENTS

In this tests, it is verified that the contribution of DER in terms of fault current is such to keep the values of short circuit currents in the network:

- compatible with the characteristics of network breakers;
- compatible with the network protection system (in particular to ensure the coordination between the protection devices);
- are not likely to exceed the limit value of I^2t for the conductors.

Furthermore, with regard to the MV network, is checked that the contribution of DER to the phase to earth fault current do not exceed the limits of compensation for the neutral grounding systems installed in primary substations.

If limits are exceeded, and this is only due to the DER object of study, as well as work on the existing network or the redefinition of technical solution, the Producer may be required to install systems that limit the contribution of its DER to fault currents.

CONCLUSIONS

Integration of DER into distribution network is a relevant issue and must be performed properly in order to ensure a safe and effective operation of the power system. Enel Distribuzione's best practices have been here described, but they only form a basis to develop network innovations that will allow in the future the expected fully integration of DER.

REFERENCES

- [1] Marco Di Clerico, Fabio Cazzato, Domenico Di Martino, Federico Marmeggi, 2012, "THE INCREASE OF DISTRIBUTED GENERATION ON ENEL DISTRIBUZIONE'S NETWORK: STATE OF THE ART, ACTIONS AND STRATEGIES FOR INTEGRATION", CIRED Workshop - Lisbon 29-30 May 2012.