

ADVANCED METERING INFRASTRUCTURE FOR REAL-TIME COORDINATION OF RENEWABLE ENERGY AND ELECTRIC VEHICLES CHARGING IN DISTRIBUTION GRID

A. Bouallaga^{1,2,3}, R. Kadri^{1,4}, V. Albinet^{1,3}, A. Davigny^{1,3}, F. Colas^{1,4}, V. Courtecuisse⁵, A. Merdassi⁶,
X. Guillaud^{1,7}, B. Robyns^{1,3}

Laboratoire d'Electrotechnique et d'Electronique de Puissance de Lille (L2EP), Université Lille Nord de France, Lille, France¹

SEOLIS, 336 Avenue de Paris, 79000 Niort, France²

HEI, 13 rue de Toul, F-59046, Lille, France³

Arts et Métiers ParisTech Centre de Lille, 8 Boulevard Louis XIV, 59 046 Lille, France⁴

GEREDIS Deux-Sèvres, 17 Rue des Herbillaux, 79000 Niort, France⁵

OPAL-RT TECHNOLOGIES, 1751 Richardson, Suite 2525 Montréal, Québec, Canada H3K 1G6⁶

École Centrale de Lille, Cité Scientifique, 59651 Villeneuve-d'Ascq, France⁷

anouar.bouallaga@hei.fr, riad.kadri@ensam.eu, Valentin.albinet@hei.fr, Arnaud.davigny@hei.fr,
Frederic.colas@ensam.eu, vcourtecuisse@geredis.fr, asma.merdassi@opal-rt.com, xavier.guillaud@ec-lille.fr,
Benoit.robyns@hei.fr

ABSTRACT

In this paper, we have designed distributed energy test platform with an advanced metering infrastructure to help assessing Electric Vehicles supervision strategy influence in real test network and evaluating communication constraint. Our designed test platform consists of following major components: real time simulator with power amplifiers, Medium Voltage network model in ePHASORSim, Electric Vehicle's emulators, and an advanced metering infrastructure information network containing smart meters, data concentrator (hub) and information system.

1. INTRODUCTION

France has made the development of Electric Vehicles (EVs) and Plug-in Hybrid Vehicles (PHEVs) an important priority of its policy to reduce Greenhouse Gas emissions. In 2009, the government launched a national program to host 2 million of EVs /PHEVs by 2020. However, large penetration of EVs in distribution network would result in potential problems on power quality (power losses, voltage drops, overloads, etc.) and generates significant investment costs [1] [2].

In this context, Seolis (Energy supplier in the French department of Deux-Sevres) initiated a project called VERDI "Renewable Energies and Electric Vehicle in Smart Distribution Networks" to deal with EVs energy demand. VERDI project's research activities focus on developing methods for optimizing and supervising the EVs load in distribution network. Moreover, VERDI's work aims to develop smart EVs recharging infrastructure that allows limiting environmental and financial impact by avoiding EVs charging during peak hours.

Thus, a supervision strategy of EVs load has been developed to provide ancillary services to the

Distribution System Operator (DSO). The studies presented in [3] and [4] showed that an adequate EVs load control using Fuzzy Logic Supervisor enables to reduce the energy transmission costs and CO₂ emissions. These objectives were achieved by smoothing power peaks caused by EVs and increasing coordination of EVs and wind-photovoltaic power sources.

In this study, supervision strategy is evaluated using an Hybrid Demonstrator linking real time simulator with physical components. It allows to:

- Assess supervision's strategy influence in real test network,
- Assess communication constraints,
- Validate technical principles by interfacing the experimental platform with smart meters and EVs charging station.

This paper is organized as following: at first, the supervision strategy principle is explained in section 2. After that, the case study characteristics are presented; it consists of test system specifications and Medium Voltage network (MV) simulation. The experimental test platform structure is given in section 4. Afterwards, experimental results are shown in section 5 and finally, conclusions and perspectives are presented in Section 6.

2. SUPERVISION STRATEGY

The supervision strategy objective is to control the Electric Vehicles (EVs) load in order to limit the energy transmission costs of the Distribution System Operator (DSO). To achieve this goal, we have to promote the local consumption of wind and photovoltaic (PV) power by coordinating them with EVs load, to maximize EVs charging during cheaper energy period and to avoid exceeding subscribed power.

At the same time, the supervision strategy manages some constraints such as the EV full charging before departure time.

The supervision strategy structure is shown in Figure 1.

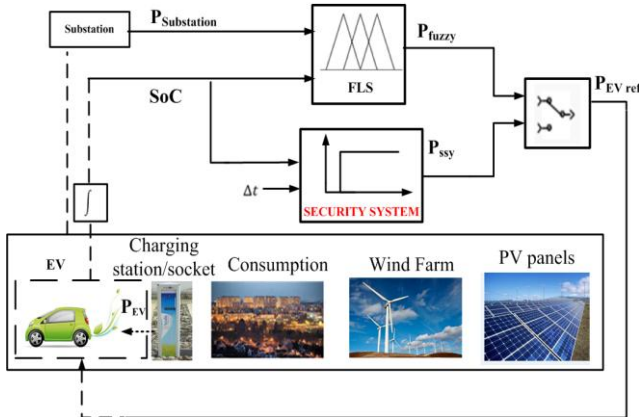

Figure 1. Supervision Strategy Architecture

The Fuzzy Logic Supervisor (FLS) aim is to maximize coordination of EVs and wind-photovoltaic power. The inputs are:

- The measured power at substation, which is equivalent to the following equation (1):

$$P_{Substation} = P_{consumption} + P_{EV} - P_{wind\ farm} - P_{PV} \quad (1)$$

Where:

$P_{consumption}$ is the power consumed by conventional electric loads (kW).

P_{EV} is the power consumed by EVs (kW).

$P_{wind\ farm}$ is the power produced by installed wind farms

P_{pv} is the power produced by installed photovoltaic panels.

- The EVs States of Charge (SoC). This variable is determined from P_{EV} ; the power provided by charging stations or home sockets to EVs.

The security system (SSy) target is to maximize EVs charging during cheaper energy period and to respect the constraint “customer comfort” ensuring the EVs fully charge before departure time.

Departure time constraint is determined from Δt input.

The supervisor’s output is power reference (P_{ref}) sent to EVs charging stations. More details about the supervision methodology are given in [4].

3. STUDY CASE

3.1. Test system specifications

The supervision strategy is applied to a real test system. Real network data are used from GEREDIS (DSO in the French department of Deux-Sèvres). The

Medium Voltage (MV) network is supplied by a 90/15 kV – 36 MVA substation. A wind farm (6.8 MW) and a total installed PV capacity of 1385 kWc are connected to this network. In addition, 81 Medium Voltage/Low Voltage (LV) substations are used to feed 1,000 customers. Finally, we consider a 15% (150 EVs) penetration level of EVs; it is assumed to be the optimistic scenario in 2020. The EVs are supposed to charge twice a day, at workplace and at home. The Figure 2 shows the network one-line diagram.

3.2. Medium Voltage network simulation

In a first stage, the MV network (illustrated in Figure 2) model has been carried out on the PowerFactory software developed by DlgSILENT [5]. As this simulation software does not allow real-time operation, a new solver called ePHASORSim and developed by Opal-RT [6] has been used to obtain a real-time simulation. An interface tool has been created and used to translate a Powerfactory simulation into an ePHASORSim simulation.

The cables, lines, switches and 36 MVA substation are modeled using real data. Furthermore, the 81 MV/LV substations are modelled by an overall load curve. To generate these curves, every consumer is considered individually. Consumers are modelled by a typical consumption curve, according to their types (residential or professional). Then by using subscribed power for each consumer, a consumption curve for each MV/LV substation is calculated, relatively to the sum of all subscribed power of each substation. Figure 3 shows an example of a MV/LV substation load curve during a day. Finally, the PV and wind power are modelled using real measurement.

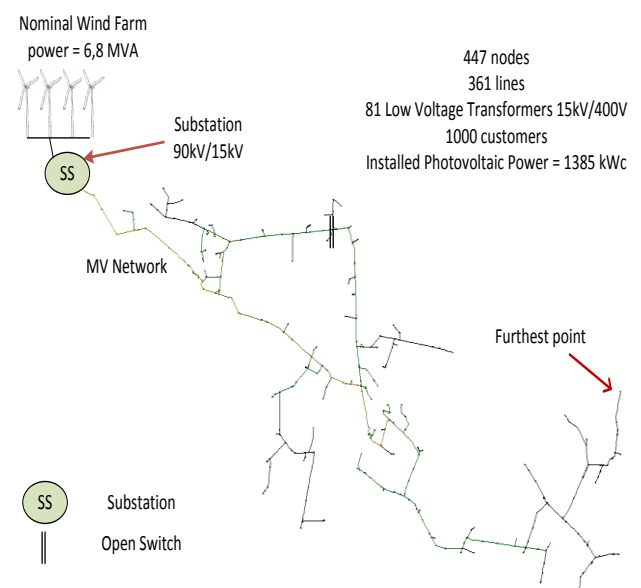

Figure 2. Medium Voltage network specifications

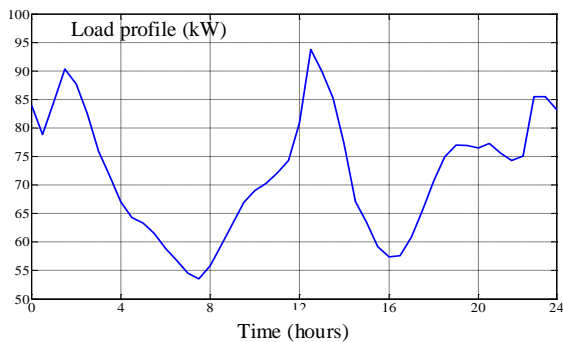

Figure3. 24-hours load profile of a LV distribution network

4. EXPERIMENTAL TEST PLATFORM

L2EP lab has designed and installed a distributed energy test platform to back up future distribution network research with nearly real-world situations. The test platform consists of three main components: (1) real time simulator with power amplifiers, (2) customer loads emulators such as EV and (3) Advanced Metering Infrastructure. Figure 4 shows the whole system structure.

Firstly, two customers are extracted from the test network to recreate the test bench using: smart meters, charging station and batteries emulators.

Secondly, the voltage signal at the meters connection points is reconstructed using phasor / EMT (ElectroMagnetic Transient) block. A 50 Hz sinusoidal signal is applied to power amplifiers. This allows injection of power signal to meters and connected loads. The provided current by power amplifiers is measured and transmitted to real-time simulator.

Finally, two additional elements are needed to ensure communication between all elements: the Hub and the Information System (IS). Therefore, communication between hub & smart meters will be carried thanks to a Power Line Communication (PLC). In addition, hub can communicate with IS and File Transfer Protocol (FTP) server via General Packet Radio Service (GPRS). Moreover, the EV supervisor communicates with IS using TCP/IP protocols. FTP server is used to store both EV charging commands and measurements. The charging commands of EV loads "batteries emulators" are sent from smart meters to charging station using smart meters dry contact output. So, if charging command is "sec_{on}" a signal is sent to power up charging station and if charging command is "sec_{off}", charging station is power down.

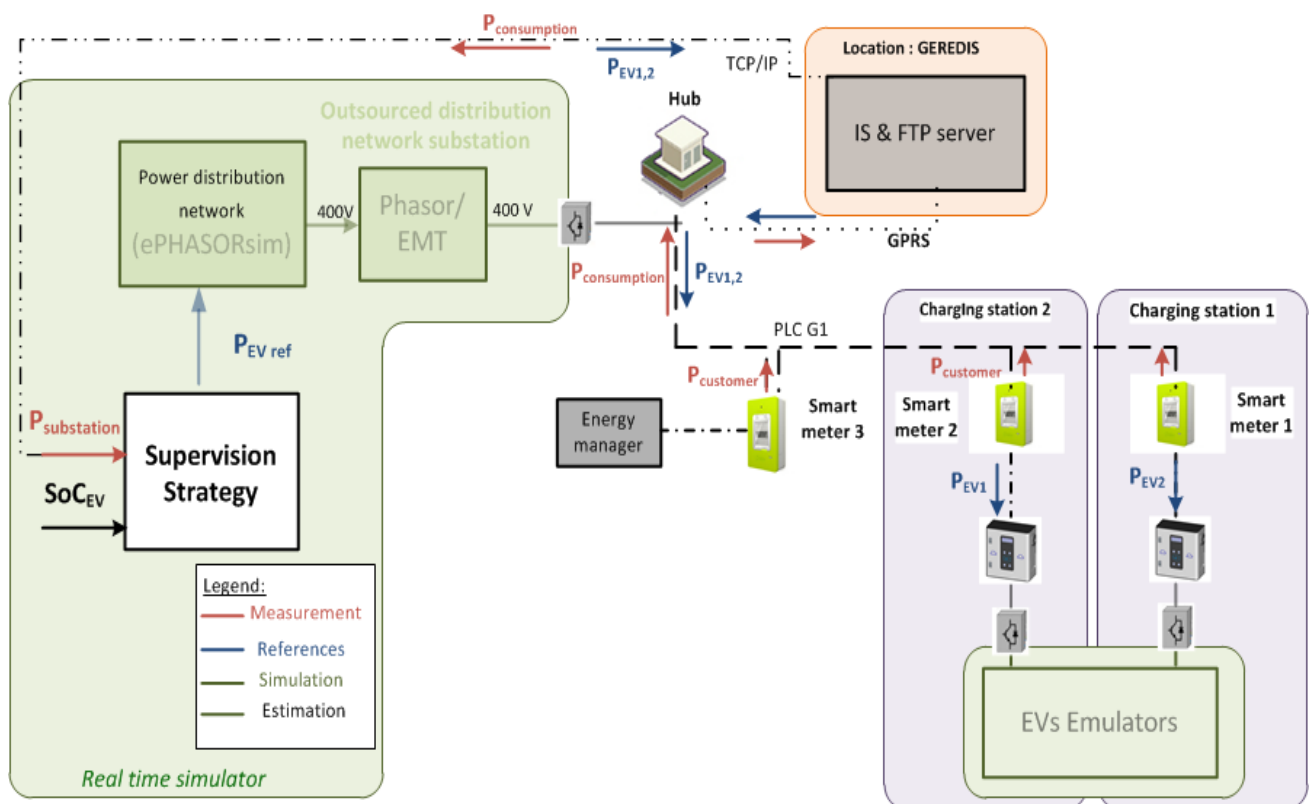

Figure4. Test platform overview

5. REAL TIME VALIDATION

To assess supervision's strategy influence in real test network, we consider a scenario with high consumption and wind power production. The profiles used are shown in Figure 5. Moreover, 1 hour real time simulation period and 0.1 second calculation step are considered in ePHASORSim simulation.

The real time validation results are given in Figures 6 to 10. They respectively represent: measured power at substation, overall MV load consumption, voltage profile at furthest point, EVs load profile and EVs charging commands. Results presented in Figures 6 to 9 make a comparison between different load curves: consumption, consumption without EVs supervision strategy and consumption with EVs supervision strategy.

As we can see in Figure 7, supervision strategy allows EVs charging during medium and low energy period cost. Furthermore, coordination of EVs and wind power is maximized unlike to uncontrolled EVs load scenario.

However, as illustrated in Figure 7, this strategy leads to peaks power at MV network level. At the same time, in Figure 8, the voltage at the furthest point drops significantly. These problematic are due to coincidence between demand and wind power peaks. This scenario can be considered as the worst one for peak shaving and voltage drops at MV network level.

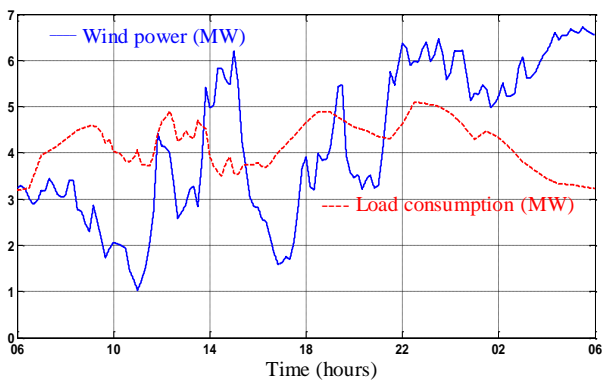

Figure5. Wind power and load consumption profile

Furthermore, EVs charging commands sent to two charging station are presented in Figure 10. They result from overall profile of supervised EVs given in Figure 9. An algorithm was developed to allocate the overall power references on all EVs. It takes into account arrival time and state of charge of each EV.

As we have considered that EVs will be charged twice a day; at home and at workplace, in Figure 10 we can distinguish two signals sent to two smart meters (1 & 2). Signal sent to smart meter "3" is also represented but currently there is no load connected to this smart meter.

Concerning communication constraints at test platform, they only depend on internet speed connection and time information processing for IS. Delays range is around 30 seconds to 3 minutes.

For reason of confidentiality, a screen print of results saved by IS cannot be displayed.

In addition, disturbances that could be produced by PLC are not observed in these experimentations.

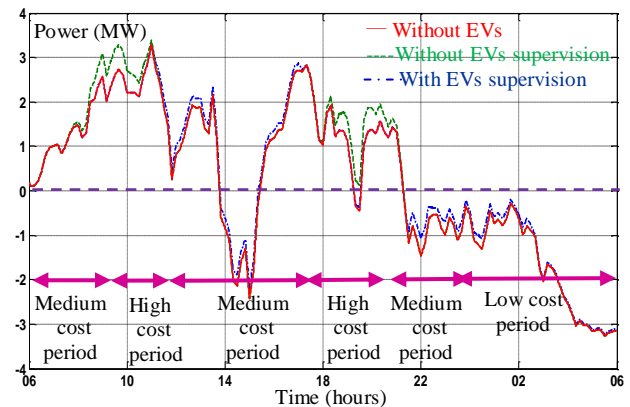

Figure6. Measured power at substation

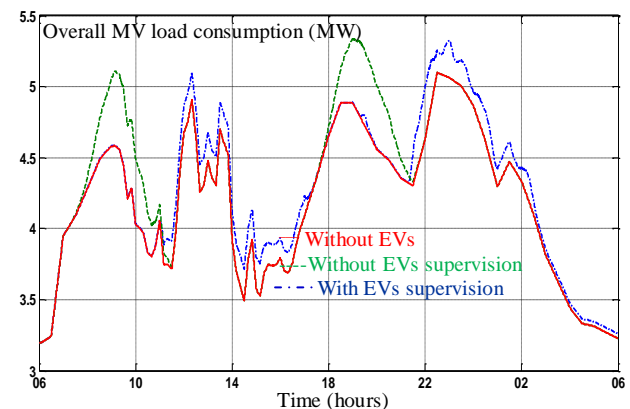

Figure7. Overall MV load consumption

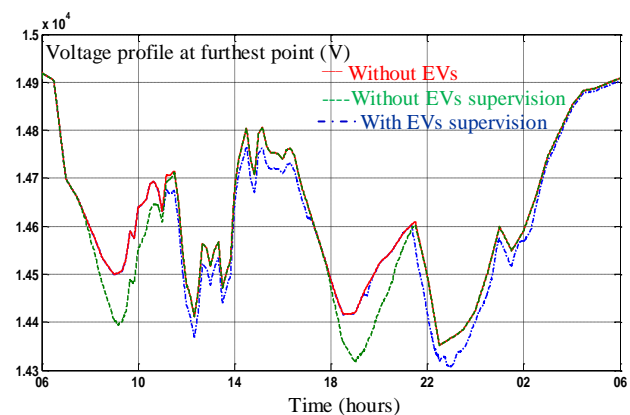

Figure8. Voltage profile at furthest point

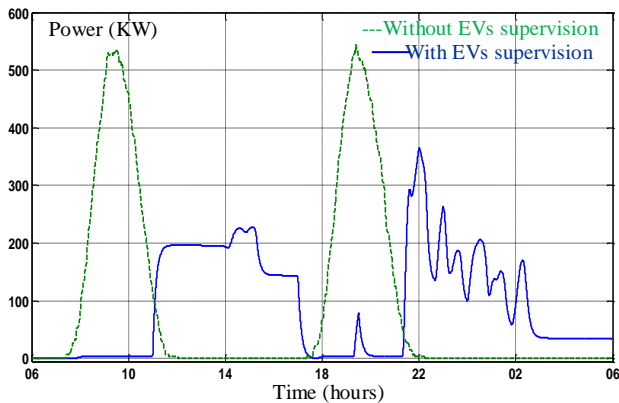

Figure9. VE profile

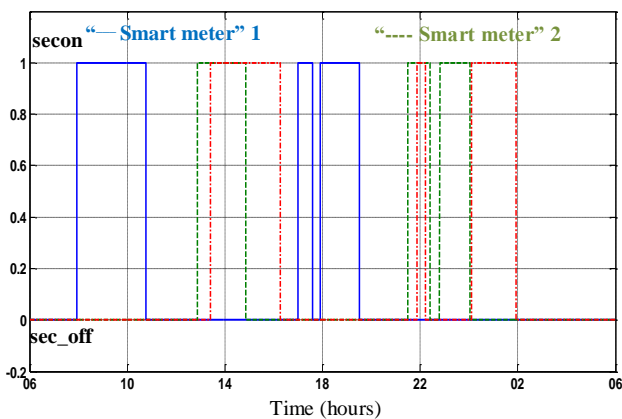

Figure10. EVs charging commands

6. CONCLUSION AND PERSPECTIVES

This paper has proposed a designed distributed energy test platform with a real time simulator and advanced metering infrastructure. Test platform is used to: assess EVs supervision strategy influence in real test network, to evaluate communication constraint and to validate technical principles by interfacing the experimental platform with smart meters and EVs charging station.

The paper showed that minimization of energy transmission cost for DSO can lead to an increasing peak power and a degradation of voltage profile at MV network level. So, in future work these problematic must be included in supervision strategy.

In addition, communication chain from Information System until charging station and going through smart meters and hub was validated. The identified communications constraints depend on depend on internet speed connection and time information processing for IS. Furthermore, disturbances caused by PLC are not observed in these experimentations.

In future work, the developed advanced metering infrastructure will be tested at large-scale by controlling more than 15 EVs.

ACKNOWLEDGEMENT

This work has been supported by Séolis Company (Energy supplier in the French department of Deux-Sevres), ANRT (Research and Technology National Agency), Nord – Pas de Calais Regional Council and MEDEE (Motors and Electrical Devices for Energy Efficiency) research cluster".

REFERENCES

- [1] V. Murin, D. Osso, M. Sarr, H. Bouia, C. Bathany, J. Maire. 2010, "Prospective study on the impact of electrical vehicles on the winter load peak in a village of East of France", EDF-R&D CIGRE.
- [2] L.P. Fernández, T.G. San Román, R. Cossent, C.M. Domingo, and P. Frías, 2011, "Assessment of the Impact of Plug-in Electric Vehicles on Distribution Networks" IEEE Transactions on Power Systems, Vol. 26, No. 1.
- [3] A. Bouallaga, A. Merdassi, A. Davigny, V. Courtecuisse, B. Robyns, 2013, Minimization of Energy Transmission Cost using Coordination of Electric Vehicle and Wind Power (W2V), IEEE International Conference, PowerTech.
- [4] A. Bouallaga, A. Davigny, A. Merdassi, V. Courtecuisse, B. Robyns, 2014, Optimization of Fuzzy Logic Supervisor for Electric Vehicle load in Distribution Grid, Electricmas Conference. Valencia, Spain, in press.
- [5] DigSilent website, [Online] <http://www.digsilent.de/>
- [6] Opal-RT website, [Online] <http://www.opal-rt.com/>