

REDUCTION OF MEASUREMENT POINTS IN LOW-VOLTAGE GRIDS WITH HIGH PV-SHARE

Gaby SEIFERT, Julia GUTBROD, Matthias LUTHER
Chair of Electrical Energy Systems, FAU Erlangen-Nuremberg, Germany
Gaby.Seifert@fau.de, Julia.Gutbrod@fau.de, Matthias.Luther@fau.de

Annette KÖPKEN
ESTW, Germany
Annette.Koepken@estw.de

ABSTRACT

The paper presents a strategy to reduce measurement devices in the low-voltage grid, to determine an accurate approximation of the grid state at acceptable costs. The investigations are based on a large number of measurement values taken every minute in the low voltage grid for more than one year. This database is used to generate three-phase profiles for photovoltaic and load input data. Asymmetrical load flow simulations are used to compare two system models, a precise and a simplified one, for different load and PV-infeed situations. The results show a good approximation for the influence of PV-infeed in the low voltage grid. Asymmetrical load conditions are detected as the major influence factor on the simulation results.

INTRODUCTION

The expansion of photovoltaics (PVs) in Germany changes the load conditions in the distribution system. To determine the present grid state, a large number of measurement devices have to be installed, according to the high number of nodes in the low-voltage grid.

While measurements in the medium voltage and high voltage grid are common, no extensive measurements in the low voltage grid have been installed until now. Information of the current state and power quality is necessary to determine grid reinforcements and be prepared for future decisions. Therefore it is necessary to find a compromise between high costs for a measurement system and a good approximation of the current system state. On that score it is important to know how many measurement points are necessary for a good approximation of the system.

Coping with the challenge of future energy supply, the Erlanger Stadtwerke (ESTW) started the pilot project "Anger". The urban area "Anger" consists of many apartment buildings, small business and many PV-infeeds. Previous measurements show that the power of PV-infeed in this region is in the same range as the consumer load. The communication infrastructure consists of a direct fiber link from the Anger district to the ESTW headquarter. This infrastructure makes high speed data-transfer of current, voltage and power quality values to the database each minute possible. In the first step of the pilot project, the scope was on a high measurement accuracy of the grid state, so measurement devices were installed in every field of the local transformer station and in every field of the cable distribution cabinets. Smart meters were installed at every PV-infeed.

Each measured value is recorded for each of the three phases every minute. Since the consumers and PV-installations are not connected symmetrically, asymmetrical system states are detected. The focus of this

paper is to determine the minimal number of measuring points, which are necessary to get accurate results.

MODELING AND INPUT DATA

Grid structure and scenarios

The structure of the partly meshed low-voltage grid is displayed in Figure 1. You can see the local transformer station as well as the different customers and the assigned load profiles (see Table 1). This structure is used for the simulation of the first (precise) scenario. For the marked connection F1 the measured currents are compared with the simulated values for all three phases. For the comparison of the voltage drop node "BB-z" is chosen. This node is furthest away from the local transformer station and there the highest voltage drop is measured.

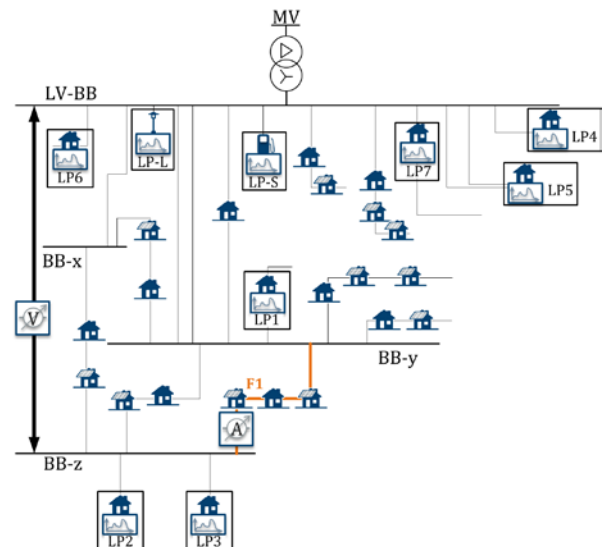

Figure 1: Structure of the low voltage grid and assigned load profiles (precise scenario)

Table 1: Load profiles (precise scenario)

| | type | number of units |
|------|-------------------------------|-----------------|
| LP1 | single, medium flat | 176 |
| LP2 | single & commune, medium flat | 214 |
| LP3 | family & commune, medium flat | 54 |
| LP4 | student residence | 202 |
| LP5 | single, small flat | 144 |
| LP6 | family & commune, large flat | 22 |
| LP7 | flat, medical practice | 32 |
| LP-L | street lighting | 1 |
| LP-S | filling station | 1 |
| | | 846 |

The number of measurement devices located in the local transformer station and the cable distribution cabinets is 31. In addition 11 smart meters are installed at the PV plants. The PV peak value, reached in 2015 was 820 kW, the peak load 834 kW.

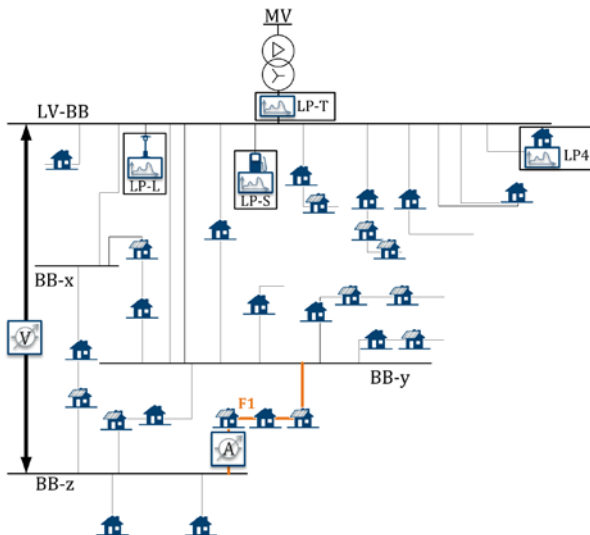

Figure 2: Structure of the low voltage grid and assigned load profiles (simplified scenario)

Table 2: Load profiles (simplified scenario)

| | type | number of units |
|------|------------------------------|-----------------|
| LP4 | student residence | 202 |
| LP-L | street lighting | 1 |
| LP-S | filling station | 1 |
| LP-T | applied transformer profiles | 642 |
| | | 846 |

The simplified scenario is displayed in Figure 2, the assigned load profiles in Table 2. The measurement points are reduced after analysis of the measured data, only 4 points are left.

Load profiles

Based on the measured values (average of one minute) for a whole year, the three-phase load profiles are generated depending on the month and weekday (“working day”, “Saturday”, “Sunday”).

Figure 3 displays three different load profiles for phase 2 of the type “winter working day” (here: January) as an example. The load profiles of the individual customers are summarized with regard to the residential groups and the apartment size. Figure 4 shows the load profile at the low-voltage side of the local transformer for phase 2, scaled with the number of households in the grid. This profile is used for the simulations in the simplified simulation. Additionally to this profile, profiles for special customers are identified and calculated such as the profile for the filling station or the street lighting (see Table 2). These

special profiles are used for both scenarios.

The profiles include the reactive power, which are not displayed here due to reasons of space.

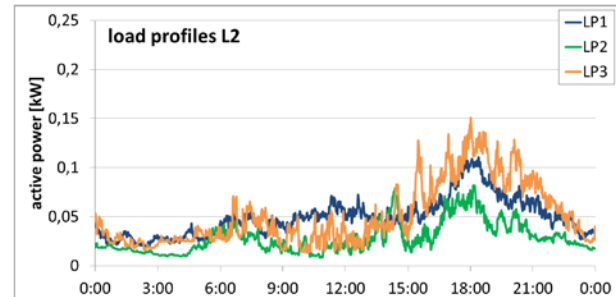

Figure 3: Load profiles LP1, LP2 and LP3 (precise scenario)

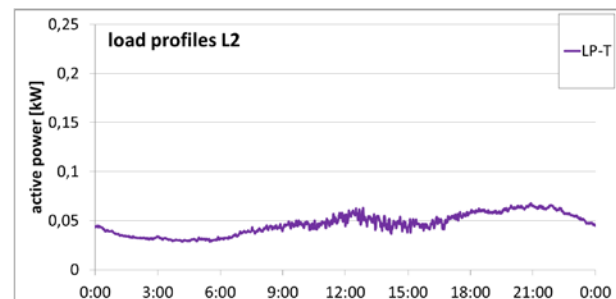

Figure 4: Load profile LP-T (simplified scenario)

PV-infeed

The infeed of every PV plant is measured in every single phase. Figure 5 displays the maximum values for the month July at each minute, scaled with the maximum value of the respective day. Three different main orientations are detected for the PV plants of this grid. The profile displayed in red, shows a plateau for the hours around noon time, caused by a limited inverter capacity. The maximum value for each orientation shows values between 86% up to 94% of the formal peak power [1]. The results of the simulation show, that the PV-infeed has to be scaled additionally to the installed converter capacity of each phase.

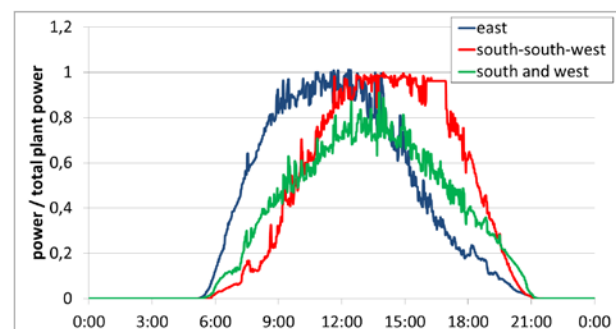

Figure 5: Load profiles of PV-installations with different orientations

SIMULATION

The simulations are carried out with the simulation engine of PSS®SINCAL [2]. Based on the three phase input data of PV-profiles and consumer profiles a load flow calculation is done to simulate the grid.

Two different scenarios were investigated: The precise simulation with 31 measurement points and the simplified simulation with 4 specially selected measurement points. The simulated value of the current in connection F1 (orange marked in Figure 1 and 2) and the voltage drop between the nodes LV-BB and BB-z are compared with the corresponding measuring values. The simulated currents and voltage drops for a typical winter working day without PV-generation and a typical summer working day with maximum PV-generation are presented for all three phases in Figure 6 to Figure 9. The profiles and the measured values are based on the evaluation period of one month.

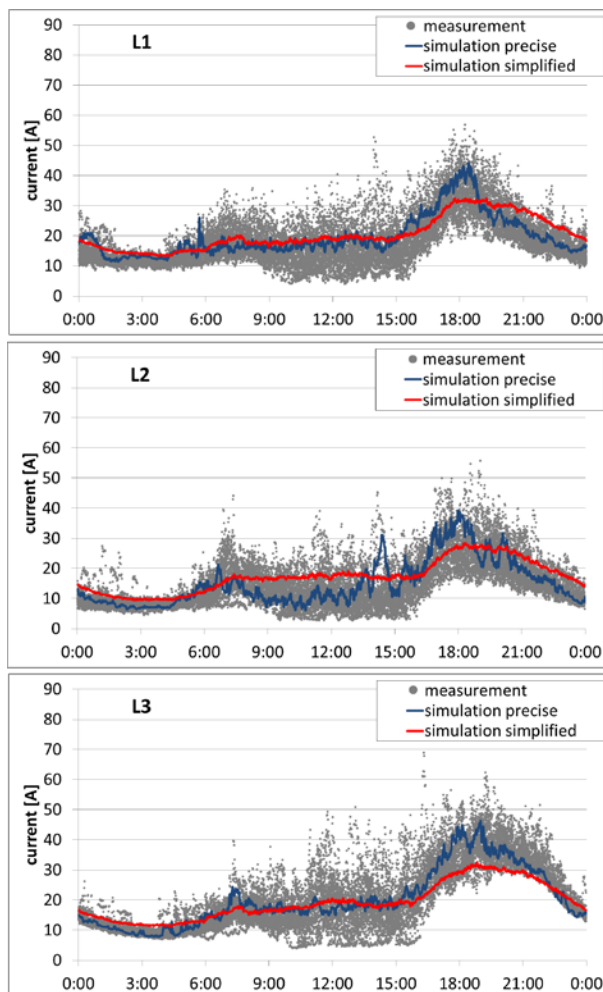

Figure 6: Current in connection F1 - winter working day (January)

Scenario “Without PV-infeed”

To distinguish between the influence of load and PV, a reference scenario of a working day in January without any PV-infeed was selected. The diagrams show the simulation results for the values of the precise simulation (blue) and the simplified simulation (red) in comparison to the measured values (grey point cloud). In Figure 6 the currents of connection F1 are displayed for all three phases. For each minute 2 simulated values as well as 18 measured values, for the 18 working days in January, are shown here.

The values of the two simulated curves are right in the middle of the point cloud most of the time. The curve of the simplified simulation is smoother than the precise simulation, due to the fact that the transformer profile averages the single profiles of the precise simulation.

The differences between the two simulation results were minimized in an iterative process. The first big progress was achieved by scaling the load profiles of the simplified simulation. The profiles of the local transformer (LP-T) were scaled with the energy of the customer type based on the resident statistics and living space of the flats. A scaling of the reactive power of these profiles did not lead to an improvement, but a relocating of the curve was more successful.

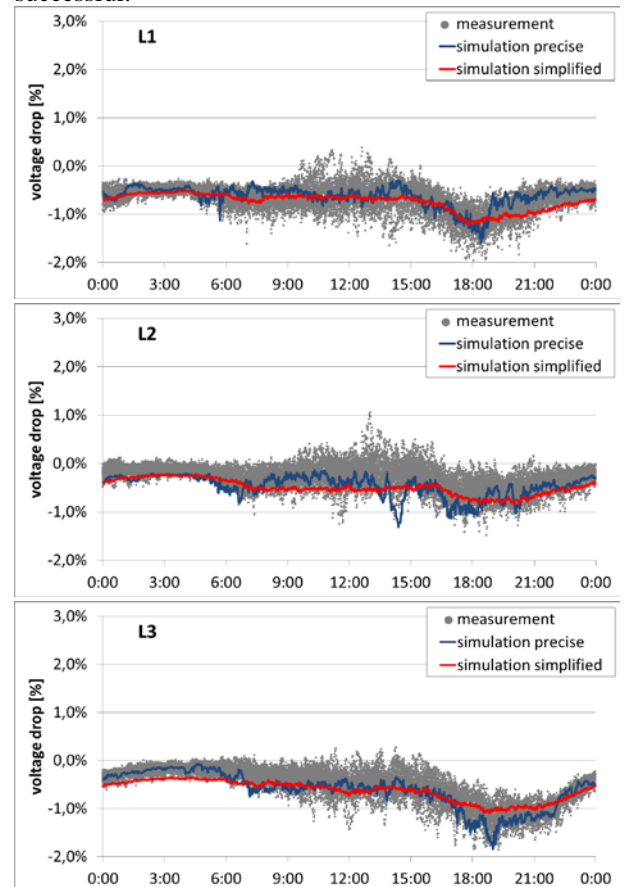

Figure 7: Voltage drop - winter working day (January)

In any case it is necessary to have separate measurements for the special customers such as the filling station and the student residence.

Further investigations concern the range of the point cloud and the analysis of the utilization factor in the grid. Maximum load profiles have been generated to learn more about the upper bound of the point cloud, but the simulated values were so high, that the results could not be used.

Figure 7 shows the voltage drop for all phases on a winter working day (measured values from January). An asymmetric distribution of the voltage drop was recognized in this case. The voltage drops in phase L2 and L3 are higher for the simulation, so that their values are located at the lower bound of the point cloud.

Scenario “Maximum PV-infeed”

The worst case scenario of a working day in summer with maximum PV-infeed is discussed here. In July 2015 values for 19 working days are available to create the profiles.

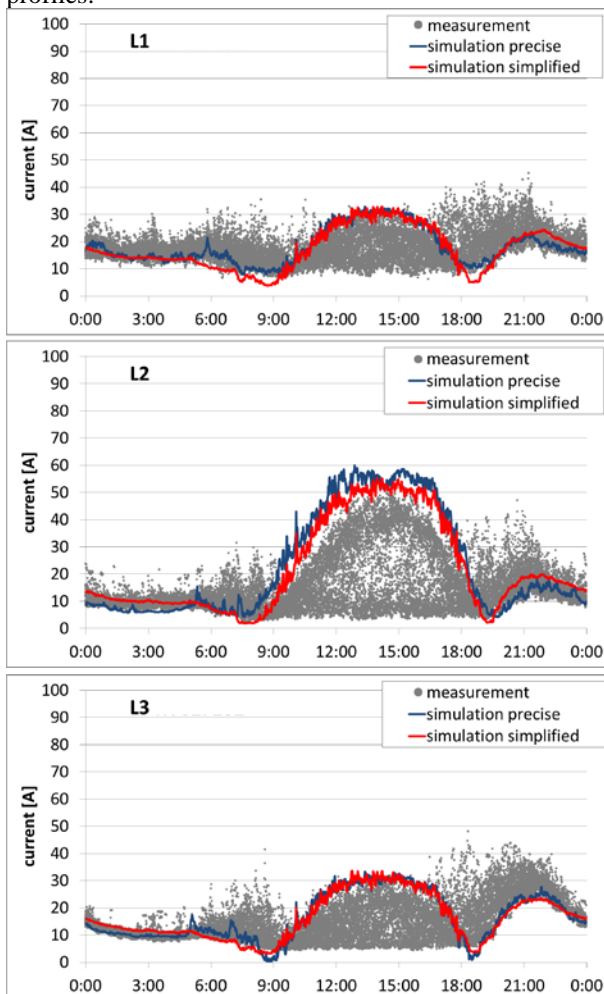

Figure 8: Current in connection F1 - summer working day (July)

The difference between the two profiles and the measured values could be minimized by scaling the three phases of the PV generation with the installed converter capacity of each phase. Figure 8 shows the results for the current in connection F1 for all three phases. The asymmetric PV-infeed is visible, but significantly compensated at the local transformer station. Nevertheless the increase of the current during the day according to the PV generation is obvious. The load profiles for July do not show good simulation results in the evening hours, but the simplified simulation is a good approximation for the value of the maximum current in all phases during the time between 8 a.m. and 6 p.m.. This is the time with the highest impact of PV generation.

Figure 9 shows the corresponding results for the voltage drop. The upper border of the point cloud has the same value as the simulation for the whole day. The simplified simulation provides an excellent approximation of the maximum voltage drop, but the results during daytime are better than in the evening hours.

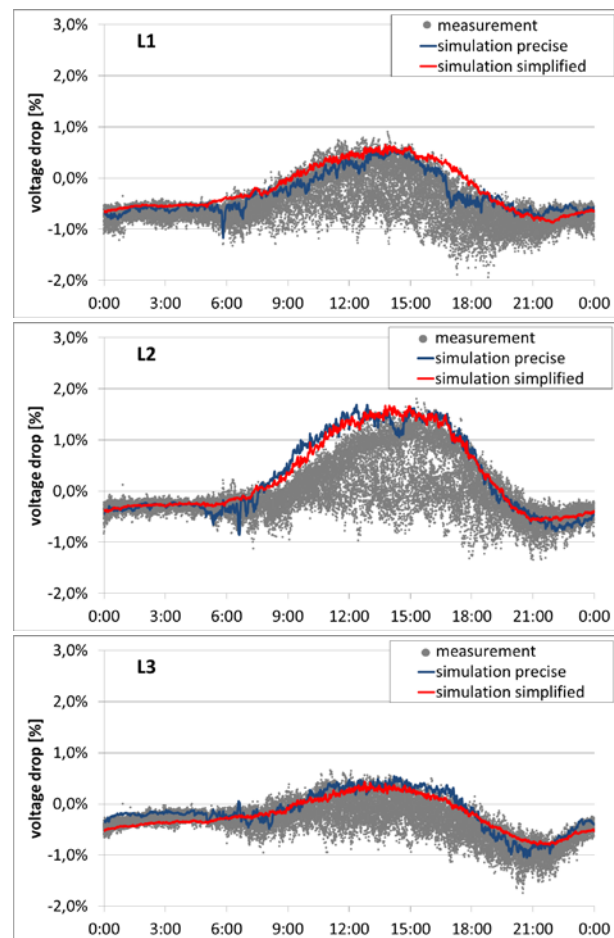

Figure 9: Voltage drop - summer working day (July)

CONCLUSION

Based on measured values of a whole year three-phase load profiles for customers and photovoltaics are generated for different months and weekdays. The measurements and the profiles contain one value for each minute of each day. Two different scenarios are investigated by an asymmetrical load flow calculation: a precise simulation, which provides profiles for nearly all measurement points, while in a simplified simulation a reduced number of measurement points and profiles are used.

The investigations show, that an optimized selection of measurement points provides results with a sufficient accuracy. The load profile of the local transformer can be used to approximate the profiles of the households, but has to be scaled with the energy according to the living space of the flat and the resident statistics. Here a uniform customer structure is favourable. Special customers have to be measured separately to get their own profiles. Examples for this kind of customer are the filling station or the street lighting in this grid. The PV-generators have to be scaled by the converter capacity of the respective phase. The simulations of the scenario "working day in January without PV-infeed" can be used to adjust the load profiles and improve the precision. So the analysis of the different consumers in a low voltage grid could simplify the simulation significantly and helps to reduce the costs for the measurement equipment.

The conclusion is that a reduced number of well-placed measurement devices combined with the simplified simulation gives a very good prediction of the impact of the PV systems on the distribution grid. The asymmetric load remains as one big influence factor. In order to save measurement points due to PV- expansion in low-voltage grids, the procedure is highly recommended.

In the next step the procedure will be transferred and tested on other low-voltage grids in the supply area of the ESTW.

REFERENCES

- [1] F. Feuchtgruber, 2014, " Analysis and preparation of time series in regard to the load flow calculation in a low-voltage grid with high PV-share (German title: Analyse und Aufbereitung von Zeitreihen für die Lastflussrechnung in einem Niederspannungsnetz mit hohem PV-Anteil)", master thesis, FAU Erlangen-Nuremberg, Chair of Electrical Energy Systems
- [2] SIEMENS AG, 2013, *PSS@SINCAL Load Flow Manual*, SIEMENS AG, Erlangen, Germany.