

## GAINING EXPERIENCE WITH A REGULATED DISTRIBUTION TRANSFORMER IN A SMART GRID ENVIRONMENT

Christian KÖRNER  
EnBW Regional AG – Germany  
c.koerner@enbw.com

Matthias HENNIG  
EnBW Regional AG – Germany  
m.hennig@enbw.com

Ronald SCHMID  
Siemens AG – Germany  
schmid.ronald@siemens.com

Karsten HANDT  
Siemens AG – Germany  
karsten.handt@siemens.com

### ABSTRACT

*The regulated distribution transformer can be a powerful tool against voltage range problems in low voltage grids with a high amount of distributed power generation. To gain experience with this new technology the German DSO EnBW Regional AG has equipped one of its MV/LV-substations with a regulated 400-kVA-transformer developed by Siemens AG.*

*This paper outlines the general benefits of using regulated distribution transformers and EnBW's steps to implement and test the aforementioned prototype. The technology of this transformer with its on-load voltage regulation is described in detail as well as the process of finding and optimizing a suitable voltage control algorithm.*

*After several months of successful operation it can be stated, that the regulated distribution transformer has proved its potential for a permanent use the realization of a new "smarter" distribution grid.*

### INTRODUCTION

For the past 100 years electrical energy has predominantly been generated in large centralized power plants, fed into the transmission grid at high voltage, and distributed to the various customers. Transformers in this distribution system have therefore typically been designed to ensure a constant load flow from higher to lower voltage levels. However, the recent growth of distributed energy resources (DER) has changed the established layout and operation of the distribution grid, leading in some regions to a temporary reverse feeding from low voltage (LV) to medium (MV) or even high voltage (HV).

Under these circumstances it has become increasingly difficult for distribution system operators (DSOs) to control the three defining features of electric power, namely current, voltage, and frequency. EnBW Regional AG operates large parts of the distribution grid in the federal state of Baden-Württemberg in South-West-Germany. Especially the more rural areas of this region have seen a significant increase in DER, especially small photovoltaic plants, while load remained at a relatively low level. The resulting load flow fluctuations make it ever more challenging for the DSO to keep voltage at each terminal within the disposable range (in Germany  $\pm 10\%$  of the rated value [1]).

Due to the long distances in rural grids, substation transformer ratios are usually set to a voltage level somewhat above the rated value to allow for the inevitable voltage drop along the line. With predictable loads this strategy works fine in most situations where electricity consumption is higher than generation (lower triangle in figure 1). However, at times of high reverse feeding and low consumption (upper triangle) voltage levels for customers at the end of the line can exceed the upper boundary of the allowed range thereby violating power quality requirements.

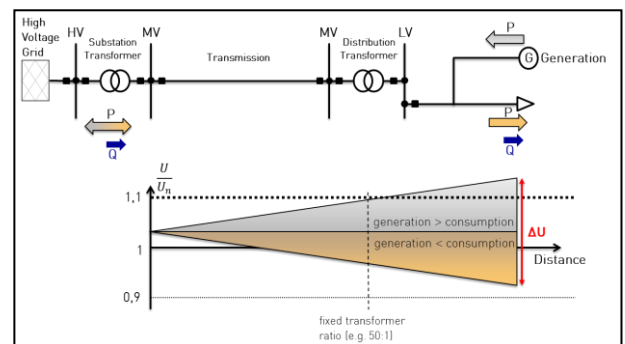

Figure 1: Voltage range violation due to high reverse feeding

Equipping substations with regulated distribution transformers (RDT) efficiently addresses the outlined problem of voltage stability. By automatically adapting its transmission ratio during operation the RDT decouples medium from low voltage which theoretically allows using the full range of  $\pm 10\%$  on the LV-level (figure 2).

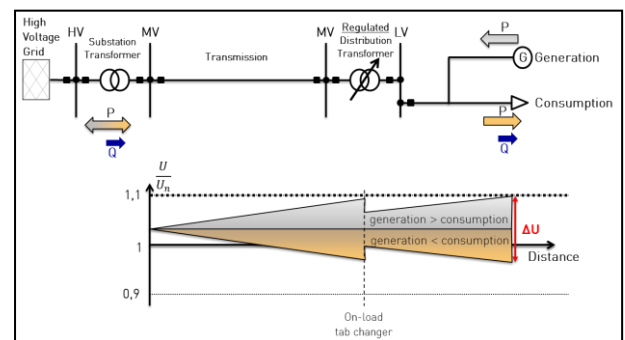

Figure 2: Voltage control using the regulated distribution transformer

The voltage control achieved by using RDTs ideally enables the DSO to fully exploit the existing transmission capacity, thus significantly reducing the cost of traditional grid reinforcement.

## TECHNOLOGY OVERVIEW

To test the benefits of a regulated distribution transformer EnBW Regional AG has equipped one of its distribution substations with a 400-kVA prototype of an RDT developed by Siemens AG. This functional model consists of two devices, a transformer and a regulation unit.

### The transformer

The transformer itself was designed with tapings on the high and low voltage side. While the high voltage tapings are led to the off-load tap changer as usual, the low voltage tapings are connected to standard bushings on the cover.



Figure 3: Transformer with low voltage terminal leads

The tapings are located at the end of the winding (side of the star point connection). With a special star point bus bar (figure 3) the tapings can be connected to operate the transformer like a conventional transformer with fixed ratio. All other connections of the transformer are the same as on a conventional one, even the LV bushings 2U, 2V, 2W and 2N.

It is obvious that tapings can be created by whole turns. In this particular design, the LV winding has 30 turns (nominal voltage). To evaluate the limits a bigger voltage control range was chosen by tapping two numbers of turns which leads us to 6.7% in plus and minus direction.

The high voltage side was specified with 21,000 V. Tapings in a range of  $\pm 2.5 / -5 / -7.5\%$  could be chosen by operating a off-load tap changer on the cover of the transformer. This allows adjusting the transformer to the situation in the grid before setting it into operation.

For environmental reasons (biodegradability and fire resistance) the transformer was filled with ester liquid.

### The regulation unit

The main components of the regulation unit are vacuum contactors, solid-state relays (thyristor-based), and an appropriate control unit (figure 4). The solid-state relay acts to ensure continuous current flow by conducting the current during the mechanical switching operations. This principal solution is under legal protection (Patent No. WO/2010/072622).



Figure 4: Regulation unit of the functional model

The regulation unit is governed by the control unit to achieve optimal coordination between mechanical and electronic switching elements. In order to reduce switching time to a minimum, voltages across the mechanical switchgear are measured in an effort to minimize the “on” time of the solid-state switch (figure 5).

Logical condition to fire thyristors:

$$|\text{voltage across contact N}| - |\text{voltage across contact 2}| > 0$$

Logical condition to extinguish thyristors:

$$|\text{voltage across contact N}| - |\text{voltage across contact 1}| = 0$$

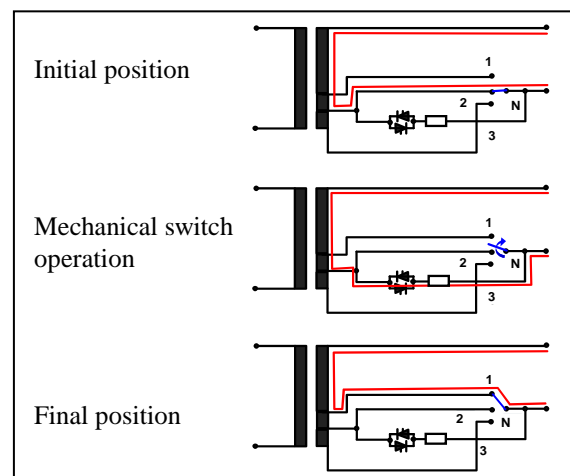

Figure 5: Commutation process

During the switching operation an inter-turn short circuit is possible. In order to limit the current flowing through the solid-state relay, a resistor is wired in series. Figure 6 depicts a switchover from position 2 to position 1

triggered by decreasing the voltage. An inter-turn short circuit of maximum 10 ms duration occurs. This current flow is limited to 5,670 A by a resistor. The results of laboratory tests performed on the functional model show no voltage or current peaks caused by switching operations.

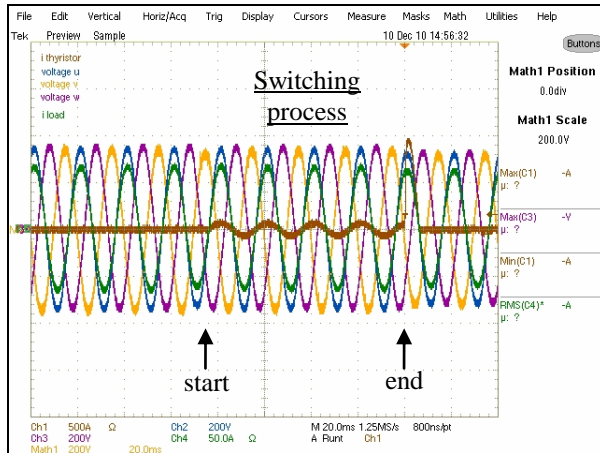

Figure 6: Measured data from “working model”

The additional losses for the regulation unit are quite low:

- no-load losses: 23.5 W
- load losses: 125 W

For additional information see [2].

## IMPLEMENTATION

A suitable site to test the described prototype under real conditions was found in Freiamt, a region in the very south-west of Germany. Freiamt has already been used for several other studies within “NetLab” - EnBW’s smart grid research project<sup>1</sup>. In this mainly rural area a maximum load of around 1.8 MW faces a peak generating capacity of currently 10.8 MW, predominantly provided by small photovoltaic power plants.

Among the around 60 MV/LV substations in Freiamt the tower station “Eckle” best fulfilled the requirements for a practical test run. The necessary control, measuring, and communication equipment needed additional room next to the new transformer. Consequently, one important aspect for choosing the right site was the available space in the substation building. Siemens’ new 400-kVA-RDT replaced the formerly used 160-kVA-transformer on August 10<sup>th</sup> 2011. After several weeks on conventional operation the control unit was installed and put into operation on September 5<sup>th</sup> 2011.

Current and voltage transformers attached to the substation’s low voltage side measure the relevant electrical data which are then analyzed with respect to

power quality by the PQI-DA measurement device from A. Eberle GmbH & Co. KG. The results of this analysis are transmitted via a GPRS-router to a data storage server at EnBW headquarters. By the same way data is provided to EnBW’s grid control center. The information is stored there for monitoring purposes and ex-post analyses only as the transformer control unit operates independently needing no direct intervention from the control center.



Figure 7: Transformer connections (left: LV, right: MV)

## OPERATING EXPERIENCE

An important characteristic of the chosen testing site was the fact that voltage levels here were significantly fluctuating but still within the allowed range. This offered the opportunity to test different control regimes without endangering overall system stability. The control algorithm uses a load-dependent adjustment of the voltage set point - a method that has already proven its merit for controlling high and medium voltage transformers [3].

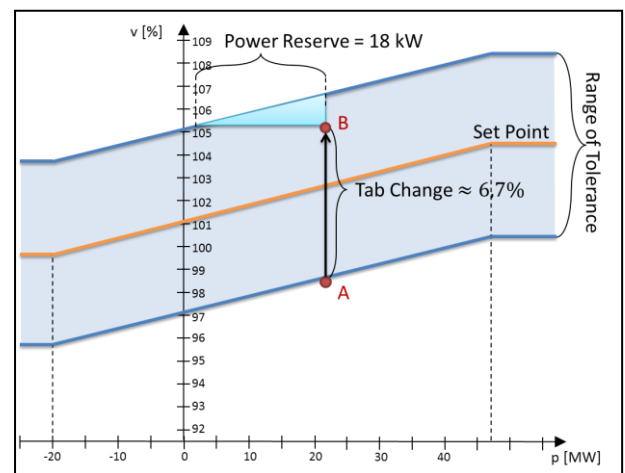

Figure 8: Control scheme

Depending on the prevailing load flow, the voltage set point is adjusted between 96% and 108% of the nominal value. A tab change is triggered every time the measured voltage is more than 4% above or below the load-dependent set point (e.g. at point A in figure 8). After the step of 6.7% voltage lies beyond the set value but still within the defined range of tolerance (point B). Starting from this working point a load reduction of more than 18 kW (power reserve) would cause the next tab change in

<sup>1</sup>visit [www.enbw.com/netzlabor](http://www.enbw.com/netzlabor) for more information



order to bring the voltage level back down.

The control algorithm for the first test run was deliberately designed more sensitively. A steeper set point curve than the one in figure 8 was used in order to cause a high number of switching operations. The goal was to observe the transformer's switching behavior and its effects on power quality. Analyzing the data gathered during approximately two weeks of operation showed that flicker problems can occur when the control algorithm makes the tab-changer switch back and forth in short succession. Short-term flickers are influenced by the height of the voltage step and the number of switching operations during a given time period. They also determine the long-term flicker value which has a negative influence on power quality as defined in EN 61000-2-2.

To address this potential flicker problem the controller was reprogrammed to the control algorithm depicted in figure 8. This new control regime led to 96 switching operations during the two-month period from November 18<sup>th</sup> 2011 through January 19<sup>th</sup> 2012. A slight increase in short-term flickers could be observed but their number did not attain a significant level to cause any long-term flicker violations.

Although the ongoing test run so far only covered the winter season, it included some sunny days which allowed the observation of the transformer's behavior in situations with a significant infeed from solar power. The recorded data indicates a strong relation between photovoltaic power generation and switching activity of the RDT. Figure 9 shows that the vast majority of the observed tab changes took place during the bright hours of the day attaining a maximum around noon.

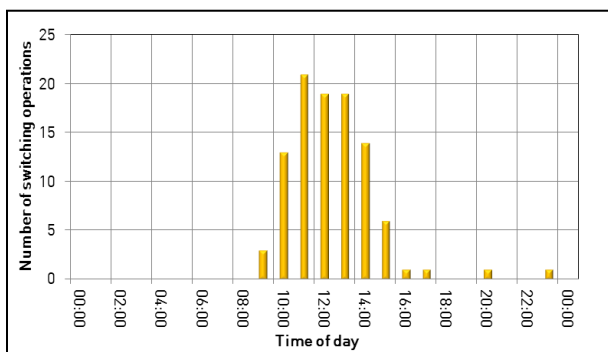

Figure 9: Distribution of the 96 switching operations recorded during a two-month period

## OUTLOOK

After the encouraging experience in Freiamt, EnBW is going to use another Siemens RDT with a smaller voltage step in the village of Sonderbuch, Germany. The voltage fluctuations here are more severe than in the first test region, which means that the RDT will actively support voltage stability. In addition to measurements at the

substation itself, the monitoring and control strategy will this time also include data from the smart meters of connected customers.

Based on the experience with prototypes like in Freiamt, most notably the existing space constraints, Siemens developed "FITformer® REG" - a regulated distribution transformer with a built-in control unit (figure 10). By keeping the accustomed performance and dimensions it ensures the changeability und comprehensive operation wherever it is needed



Figure 10: FITformer® REG

## SUMMARY

While further observations and analyses are still under way, first results show that the RDT serves its desired purpose. It was able to keep voltage within the allowed range using a reasonable amount of switching operations. Attention is required when designing the control algorithm as a too sensitive setup could achieve voltage control at the expense of a lower power quality due to flickers. With a correctly adjusted controller, however, the RDT enables distribution system operators to efficiently integrate and manage the customers' fluctuating power generation, load, and storage capabilities thus making an important step towards a smarter distribution grid.

## REFERENCES

- [1] Deutsches Institut für Normung e.V. (DIN): „Merkmale der Spannung in öffentlichen Elektrizitätsversorgungsnetzen“, DIN EN 50160, Februar 2011, Beuth Verlag GmbH, Berlin
- [2] G. Hipszki et al., 2011, "Distribution Transformers – Ready for the Smart Grid", *CIRED - 21<sup>st</sup> International Conference on Electricity Distribution*, paper No 1121
- [3] Körner, C.: Untersuchung von Konzepten zur Spannungsregelung in Mittelspannungsnetzen bei starker Einspeisung regenerativer Stromerzeuger. Universität Stuttgart, 2011