

LVSURE CONCEPT FOR AUTOMATION OF LV DISTRIBUTION NETWORKS

Gary EASTWOOD
EA Technology – UK
gary.eastwood@eatechnology.com

Mike LEES
EA Technology – UK
mike.lees@eatechnology.com

Dave ROBERTS
ScottishPower - UK
dave.roberts@sppowersystems.com

ABSTRACT

This paper describes the desktop modelling of a novel automation concept to traditional LV distribution networks based on the EA Technology “SignalSure” system, which is currently in operation on rail signalling circuits in the UK. EA Technology has carried out projects on behalf of a number of UK Distribution Network Operators through the Innovation Funding Initiative (IFI) to assess deployment options, technical constraints, benefits and safety implications. The findings from the project carried out for ScottishPower are presented in this paper.

INTRODUCTION

EA Technology has a patented automation system for single phase 660V AC rail signalling circuits called “SignalSure”. This system comprises of an Electronic Fuse Unit (EFU) at the source of the circuit and Intelligent Link Units (ILUs) at various points, which incorporate sensing circuitry to detect downstream cable faults. The system automatically isolates any ‘faulty’ section and restores supplies to the other ‘healthy’ sections without communication between the various units. EA Technology has carried out a project on behalf of ScottishPower¹ to investigate the safety, cost and technical implications of applying this technology to the automation of LV distribution networks. This application is known as “LVSure”.

SYSTEM COMPONENTS & OPERATION

The Electronic Fuse Unit (EFU) is a power electronic switching device that replaces the traditional fuse at the source(s) of the circuit. Intelligent Link Units (ILUs) are conventional load switching devices incorporating fault sensing circuitry, which replace traditional fuses / links at various sectionalising points along the circuit. The ILUs are latched in the closed position during normal operation. In the event of a short-circuit the EFU at the source of the circuit senses the fault current and trips instantaneously (i.e. within several microseconds). The subsequent loss of voltage causes downstream ILUs to unlatch and open thus automatically sectionalising the circuit. Providing there is voltage on the incoming side, the EFU will automatically reclose after a

preset time interval, typically 3 seconds, to energise the 1st downstream cable section. The EFU will remain closed if the section is fault-free. After a short time delay the incoming voltage to the 1st downstream ILU will power-up the device and its fault sensing circuitry. The ILU will then test the next downstream cable section for the presence of a fault. If the section is fault-free the ILU will close and energise the 2nd downstream cable section. However, if a fault is sensed then the ILU will not close. The ILU will periodically test the cable section and will only close if the fault condition is removed. If the circuit is a ring circuit then similarly the EFU and ILUs at the other end of the circuit will automatically reclose until the faulty section is isolated and supplies have been restored to the remaining fault-free sections on the ring.

LV NETWORK TOPOLOGIES

ScottishPower operate a traditional radial LV distribution network in suburban and rural areas. LV underground cables are supplied from Substation Cable Distribution Boards (SCDB) equipped with three-phase fuseways. A degree of interconnection is provided between adjacent distribution substations via normal open points established in underground cable link boxes. A typical radial network with LV interconnection is shown in Figure 1.

Figure 1 Typical Radial LV Distribution Network

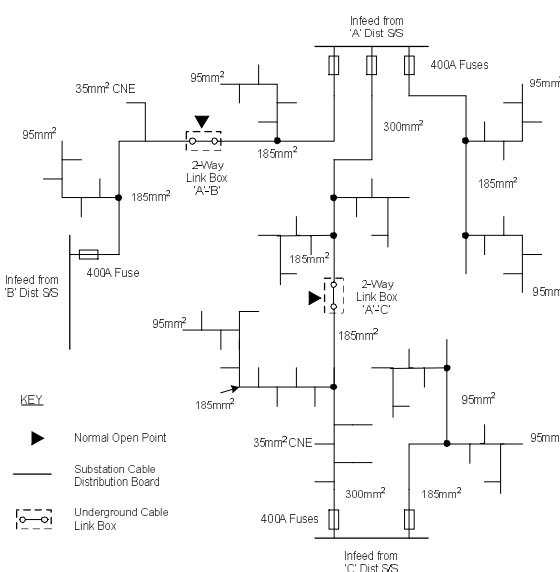

1 ScottishPower is the UK Distribution Network Operator (DNO) for the distribution systems in Merseyside, Cheshire and North Wales (SP-Manweb plc) and Central Scotland (SP-Distribution Ltd).

LV FAULTS

Two principal categories of fault occur on LV distribution networks: transient faults or permanent faults. Transient faults cause intermittent fuse operation but subsequent tests do not identify a cause for the fuse operation(s) and the circuit is successfully re-energised. Over a period of time, several fuse operations may occur before the transient fault finally develops into a permanent fault, which can then be found by traditional fault location techniques. Presently, if a transient fault occurs the associated fuse(s) on the SCDB will blow to clear the fault. Customers supplied from the affected phase(s) will be interrupted and remain off supply until an operator arrives on site and replaces the fuse(s). Similarly, if a permanent fault occurs then customers connected to fault-free cable sections will remain off supply until the operator manually sectionalises the cable and restores supplies.

BENEFITS OF LVSURE

Customer Interruptions

In the UK, the Office of Gas and Electricity Markets (Ofgem), defines a Customer Interruption (CI) as a loss of supply to a customer, which lasts longer than 3 minutes; customer supplies that are interrupted but restored within 3 minutes are not included in this performance measure. Although the deployment of LVSure in LV networks will not reduce the number of transient interruptions, any resultant CIs could be avoided because LVSure would automatically restore supplies within 3 minutes. Another benefit of LVSure would be to minimise the number of CIs associated with permanent faults by automatically sectionalising the faulty section and restoring supplies to those customers connected to fault-free cable sections.

Customer Minutes Lost

Customer Minutes Lost (CMLs) are the aggregated product of CIs and the loss of supply duration (measured in minutes) for a fault. Consequently, the deployment of LVSure would also reduce the number of CMLs associated with a fault. The greatest reduction in CMLs would occur in LV networks, which have a higher than average operator response time to a reported loss of supply.

In 2005, Ofgem introduced a penalty / reward mechanism under the Information and Incentives Programme (IIP) which links CI and CML performance to money (+/-2% turnover p.a.). Stringent targets for each Distribution Licence area were set in a bid to provide economic drivers to improve supply quality and even out geographical / company disparity across the UK.

Fault Clearance Times

The fault clearance time of the EFU is in the order of several microseconds. As a result the probability of secondary faults occurring, caused by the passage of fault current, could be

reduced compared with fuse protection. There is also a major safety benefit because the fault energy, which is proportional to the fault clearance time squared, will be reduced significantly. Consequently, the risk of injury to third parties, who cause acute damage to cables, could be reduced where LVSure is deployed.

DEPLOYMENT OPTIONS

Several possible applications for this technology have been identified, principally for retrofitting to existing radial and interconnected LV networks. For simplicity, only the application of LVSure components to LV radial networks is presented. A typical deployment is shown in Figure 2.

Figure 2 Typical LVSure Deployment

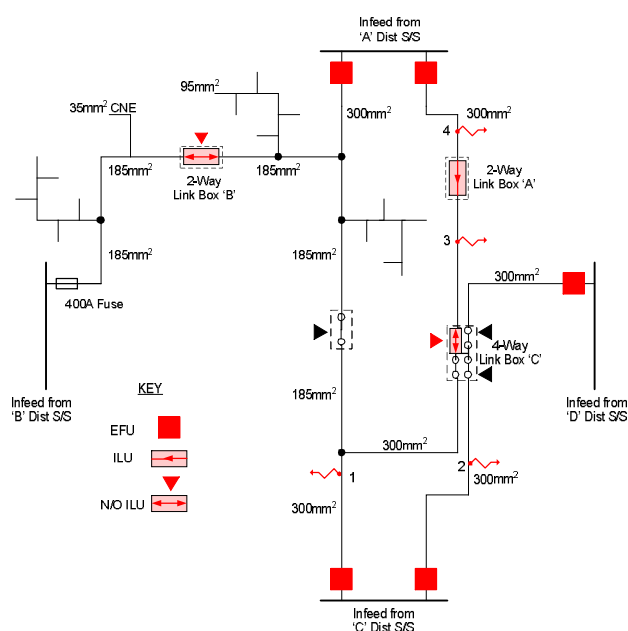

In summary:

- Fuses would be replaced with EFUs at 'A', 'C' and 'D' Dist S/S SCDBs;
- Solid links would be replaced by ILUs in 2-way link box 'A';
- Solid links would be replaced by N/O ILUs in 2-way link box 'B';
- Solid links would be replaced by N/O ILUs in circuit 'A' of 4-way link box 'C'.

Automatic Restoration of Transient Faults

A transient fault at location '1' or '2' would cause the associated EFU at 'C' Distribution Substation to open. Because the fault is transient the EFU would automatically reclose and restore customer supplies within 3 minutes thus avoiding 100% of the CIs and CMLs that would have otherwise resulted in a traditional fused circuit.

Automatic Sectionalisation of Permanent Faults

The sequence of operations for a permanent fault at location '3' would be as follows:

- EFU at 'A' Dist S/S would open;
- ILU in 2-way link box 'A' would open following supply loss;
- EFU at 'A' Dist S/S would reclose successfully;
- ILU in 2-way link box 'A' would test the downstream cable section, detect a fault and remain open.

It is apparent that a permanent fault at location '3' between 2-way link box 'A' and 4-way link box 'C' would be automatically sectionalised and supplies would be restored by LVSure to the unaffected customers between 'A' Distribution S/S and 2-way link box 'A' within 3 minutes thus avoiding 50% of the CIs and CMLs that would have otherwise resulted in a traditional fused circuit. At present, manual fault sectionalisation and supply restoration of those unaffected customers is delayed by the response time of the operator.

ESTIMATED COST SAVINGS

A summary of the estimated benefits for deployment in LV radial networks, in terms of CIs avoided, CMLs avoided and reduced final restoration times is shown in Table 1.

For the 5 year regulatory period 2005/06 to 2009/10, ScottishPower have calculated that the average cost of an individual customer CI and CML in the SPM distribution area is £11.99 per CI and £0.15 per CML. Using these figures the estimated costs that could be avoided in terms of reduced CIs and CMLs by deploying LVSure are shown in Table 2. The upper table shows the estimated cost savings for transient faults and the lower table permanent faults. The estimated costs savings are based on an average of 50 CIs per fault and an average 1st restoration time of 2.5 hours, which were typical from analysis of fault data provided.

It is clear from Table 2 that the greatest cost savings on a per fault basis are associated with the restoration of transient faults as opposed to automatic sectionalisation of permanent faults. However, these cost savings are only estimates at this stage and will depend upon the deployment strategy and associated costs of the system and installation.

PREFERRED STRATEGY

An analysis of LV network and fault data provided by ScottishPower showed that LVSure would deliver the greatest benefits for typical LV radial networks in high density urban and suburban areas, which have the highest average customer connections per feeder and the longest average 1st restoration times. It was also found that cables in these areas are also prone to third party damage and suffer from a higher than average number of latent transient faults caused by moisture ingress.

Table 1 Summary of Estimated Benefits for LVSure

Deployment Option	Transient			Permanent		
	CIs	CMLs	Restoration Time	CIs	CMLs	Restoration Time
Option 1 Fused Radial No LV Interconnection	Up to 100% Avoidance of CIs	Up to 100% Avoidance of CMLs	Reduction in 1 st Restoration of 2 hours	No Benefit	No Benefit	No Benefit
Option 2 Fused Radial LV Interconnection 1 Cable Section	Up to 100% Avoidance of CIs	Up to 100% Avoidance of CMLs	Reduction in 1 st Restoration of 2 hours	No Benefit	No Benefit	No Benefit
Option 3 Fused Radial LV Interconnection 2 Cable Sections	Up to 100% Avoidance of CIs	Up to 100% Avoidance of CMLs	Reduction in 1 st Restoration of 2 hours	50% Reduction	Avoided CMLs 1 st Restoration = 0.5C x 120 Final Restoration = 0.5C x 30	Reduction in Restoration Time 1 st = 120mins Final = 30 mins
Option 4 Fused Radial LV Interconnection 3 Cable Sections	Up to 100% Avoidance of CIs	Up to 100% Avoidance of CMLs	Reduction in 1 st Restoration of 2 hours	66.6% Reduction	Avoided CMLs 1 st Restoration = 0.67C x 120 Final Restoration = 0.33C x 30	Reduction in Restoration Time 1 st = 120mins Final = 30 mins

Table 2 Estimated Costs of Avoided CIs & CMLs

No. Transient Faults	Average CIs/Faults=50 Average Restoration Time = 2.5 hours														
	1 Cable Section/Circuit					2 Cable Sections/Circuit					3 Cable Sections/Circuit				
	1	2	3	4	5	1	2	3	4	5	1	2	3	4	5
Cost CIs Avoided	£600	£1,199	£1,798	£2,398	£2,998	£600	£1,199	£1,799	£2,398	£2,998	£600	£789	£1,199	£1,799	£2,398
Cost CMLs Avoided	£1,125	£2,250	£3,375	£4,500	£5,625	£1,125	£1,888	£2,250	£2,813	£3,276	£1,125	£1,500	£2,250	£3,375	£4,500
Total Costs Avoided	£1,725	£3,449	£5,174	£6,898	£8,623	£1,725	£3,449	£5,174	£6,898	£8,623	£1,725	£3,449	£5,174	£6,898	£8,623

No. Permanent Faults	Average CIs/Faults=50 Average Restoration Time = 2.5 hours														
	1 Cable Section/Circuit					2 Cable Sections/Circuit					3 Cable Sections/Circuit				
	1	2	3	4	5	1	2	3	4	5	1	2	3	4	5
Cost CIs Avoided	£0	£0	£0	£0	£0	£300	£600	£899	£1,199	£1,499	£400	£789	£1,199	£1,599	£1,998
Cost CMLs Avoided	£0	£0	£0	£0	£0	£563	£1,125	£1,688	£2,250	£2,813	£750	£1,500	£2,250	£3,000	£3,750
Cost Final Restoration CMLs Avoided	£0	£0	£0	£0	£0	£0	£0	£0	£0	£0	£75	£150	£225	£300	£375
Total Costs Avoided	£0	£0	£0	£0	£0	£863	£1,725	£2,587	£3,449	£4,311	£1,225	£2,449	£3,674	£4,899	£6,123

From this a preferred strategy for deploying this technology has been clearly identified, which could significantly reduce the number of customer interruptions, total customer minutes lost and overall restoration times for existing LV underground cable networks.

Existing Networks

Worst Performing Circuits

A targeted strategy for deployment in specific circuits is initially foreseen rather than widescale deployment across the whole LV network due to the cost of deployment. The preferred strategy is to target known 'rogue' or worst performing circuits with high fault incidence rates. LVSure would be typically installed on these circuits for a period of between 6 months and 3 years until network reinforcement is completed. Initially, the strategy would focus on reducing CIs and CMLs associated with transient faults in radial circuits with single cable sections, which constitute the majority of all LV circuits. It is intended that 'rogue' circuits would be identified, which are expected to have a fault incidence rate of 2 or more transient faults in a 1 year period or at least 3 transient faults and 1 permanent fault in a 3 year period.

Multiple Cable Sections in Dense Urban Networks

In the medium term, the strategy would be to install LVSure in densely populated urban areas on LV underground cable circuits with 2 or more cable sections and which have good LV interconnection. LVSure would be used to automatically restore transient faults and sectionalise permanent faults so that supplies to large numbers of customers connected to the healthy sections could be restored automatically within 3

minutes of the fault occurring.

LV Network Redesign

However, it is apparent that the number of deployment opportunities can be maximised in future by changing the design of new LV networks so that the number of accessible sectionalising points along LV underground cable circuits are increased and there is sufficient space available to retrofit LVSure components, if required, at a later date. Design considerations include the deployment of additional link boxes and underground service distribution boxes.

TECHNICAL CONSTRAINTS

A number of technical constraints have been identified with transferring the existing single phase 660V AC rail signalling technology to LV distribution networks. These constraints and proposed solutions are discussed below.

Continuous Current Rating

In LV distribution networks main current carrying components should ideally be suitable for operation at continuous rated currents up to 630A, which is considerably greater than for existing railway signalling applications. A system for continuous current ratings up to 400A is considered to be technically feasible using existing components with enhanced current ratings. However, substitution of power electronic devices with more expensive vacuum interrupter technology would be an alternative option at higher ratings.

On-state Conduction Losses

In the LV distribution network the on-state conduction losses using power electronic devices are estimated to equate to 0.4% of distributed energy at full load. Although such losses may not be acceptable across the entire LV network the benefit from reduced CIs & CMLs could offset the additional on-state condition losses for targeted deployment. This will need to be assessed against any 'losses incentive' introduced by Ofgem. Notwithstanding, on-state conduction losses for this application could be reduced in the long term as a result of significant innovations in power electronic semiconductor devices and application circuits.

Fault Detection Method

The single phase fault detection method and circuitry used in the SignalSure system may not be suitable for detecting more complex faults within three-phase LV distribution networks without modification. Consequently, it is proposed to carry out further work with a view to incorporating a more sophisticated method based on modern fault location technology that will reliably detect the range of three-phase fault conditions and distinguish between high impedance faults and parallel load impedances.

Physical Limitations

The space available to mount LVSure components in modern

fully enclosed SCDBs and link boxes is more restrictive than for traditional open-type indoor LV boards. The preferred solution is a universal design that can be retrofitted in both traditional and new network equipment. This will include high speed fuses to provide back-up short-circuit current protection in the event that the power electronic switch fails to clear the fault. A number of solutions are being considered, which include retrofitting new recessed doors to enclosed SCDBs and increasing the height of the diving bell lid within underground link boxes.

SAFETY & OPERATIONAL IMPLICATIONS

A review of UK legislation indicates that there are no major barriers to the introduction of the LVSure system on underground LV networks providing that LVSure components comply with relevant Energy Network Association (ENA) Technical Specifications. A number of features that would improve safety and operability have been identified, which include: remote indication of system operation and alarms, fault waveform capture and provision to manually inhibit auto-reclosure for switching and work activities on / in close proximity to LV underground cables. Before proceeding with any trial installation a more detailed risk assessment will be undertaken concerning the risks associated with LV auto-reclosure and the capability of LV underground cables to withstand multiple fault reclosures.

CONCLUSIONS

LVSure represents an interesting development for automation of LV distribution networks. The avoidance of unnecessary CIs and CMLs by automatically sectionalising permanent faults and restoring supplies to healthy sections within the existing threshold limit of 3 minutes would be a key benefit. Unlike traditional automation systems, LVSure does not require a communication system to determine the status of system components or configuration of the LV network. ScottishPower is collaborating with a number of other UK Distribution Network Operators to fund the development of a prototype system with the intention of carrying out a small scale network trial to prove the concept and verify the benefits.¹

REFERENCES

- [1] G.Eastwood, M.Lees, 2007, LVSure Network Automation Phase 1 Reports (No. 6086, 6088 & 6073), EA Technology.

¹ EA Technology & ScottishPower would like to acknowledge participation in similar LVSure projects by EDF Energy, Scottish & Southern Energy and Electricity North West Ltd.