

IMPLEMENTATION OF INTERACTIVITY ACROSS A RESILIENT MICROGRID FOR POWER SUPPLY AND EXCHANGE WITH AN ACTIVE DISTRIBUTION NETWORK

Peng LI
L2EP - Ecole Centrale de Lille
lephis@gmail.com

Philippe DEGOBERT
L2EP - ENSAM
Philippe.DEGOBERT@ENSAM.EU

Benoit ROBYNS
L2EP - HEI
benoit.robyns@hei.fr

Bruno FRANCOIS
L2EP - Ecole Centrale de Lille
bruno.francois@ec-lille.fr

ABSTRACT

This paper presents the results of a research project whose objective is to extend obtained capabilities of a resilient microgrid to a conventional distribution network. This system has been previously sized and optimized to fully operate in an autonomous way. The presented work is an advanced interface control system for grid connection of this cluster in order to provide the over power in compliance with the distribution network. As a result, the Distribution System Operator considers this locally controlled cluster as a single producer.

INTRODUCTION

The operation of the power grid system requires meeting a few essential reliability objectives like: continuous balancing of generation and demand, transmission system security, emergency preparedness, system control etc. The main change in the future European electricity market will affect the power reserve management [1]. Having a large power reserve will be a key for successful operation. The reserves are usually analyzed as slow access reserves and quick spinning reserve. Currently spinning reserves are the online generating equipments which are synchronized to the grid that can increase output immediately in response to variations in frequency or on demand. These reserves can be fully available within 10 minutes. Currently gas turbines and hydraulic power plants are used to provide quick spinning reserves. The increasing need in quick spinning reserves and the politic environmental wishes require finding new clean niches for reserves.

This paper presents the results of a research project whose objective is to extend obtained capabilities of a resilient microgrid to a conventional distribution network. An advanced interface control system for grid connection of this cluster is developed in order to provide the available over power in compliance with the distribution network (fig. 1). As a result, the Distribution System Operator (DSO) considers this locally controlled cluster as a potential power reserve contributor.

I. CONFIGURATION OF THE CONSIDERED MICROGRID

In Europe, a large development of PV and wind generators is awaited and planned to create a sustainable energy system in order to reduce emission of CO₂. These renewable energy based generators are well known by grid operators as random energy generators with limited capabilities for providing ancillary services.

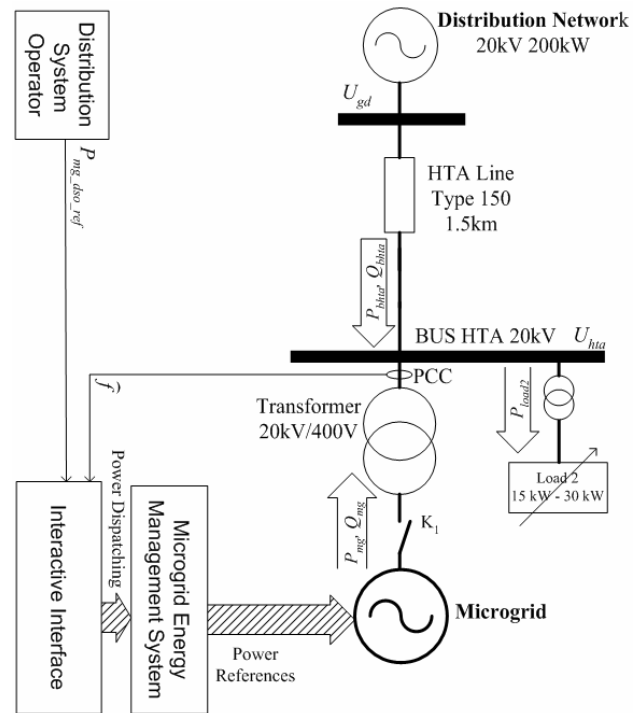

Figure 1: General organization of the system

In order to facilitate the integration of more renewable energy based generators, a possible solution is to associate them with local conventional generators, local storage units and a set of local flexible loads. The optimum management of this energy system is the key to increase the efficiency, the supply, the safety, reliability and quality of the energy distribution in this local area for end-users [2]. This future active network has to coordinate small and medium scale power sources with consumer demands, allowing both to decide the best operation in real time. It can be viewed as a microgrid, which is able to locally control a cluster of generators and flexible loads in a decentralized way and to permit renewable energy based generators to provide their full benefits. Practical implementations are under development in Europe at Kytinos island (Greece), at Mannheim-Wallstadt (Germany).

The studied microgrid comprises a 30kW Gas Micro Turbine (GMT), 17kW PV generators and a total of 30kW end-users (fig. 2). This system has been previously sized and optimized to fully operate in an autonomous way. All sources are grid-connected with power electronic converters within a dedicated control system and communication interface with a Microgrid Energy Management System (MEMS). Inside this microgrid two units of 2.3kW.min of ultra capacitors are used as energy buffer in order to smooth PV powers and to track the optimal operating point of the GMT unless load variations and PV power production variations.

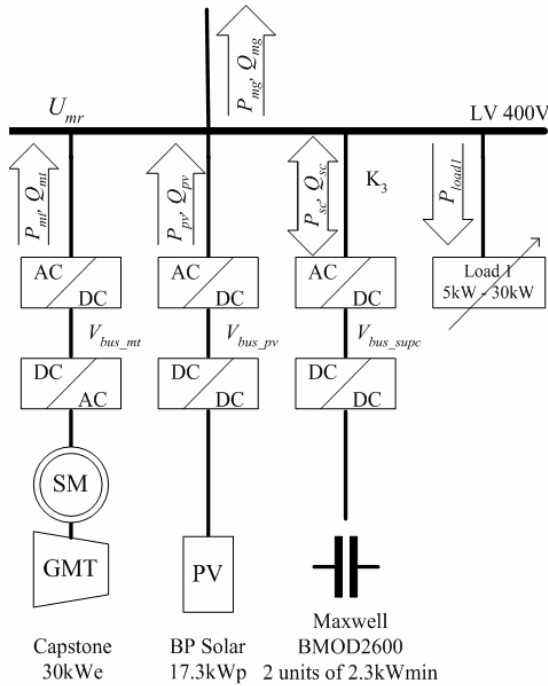

Figure 2: Synoptic of the studied microgrid with useful powers

II. INTERACTIVE INTERFACE WITH THE DISTRIBUTION NETWORK

General description

The interactive interface implements the grid integration of the microgrid and coordination with the distribution network (fig. 1). It includes frequency and voltage control algorithms at the PCC within a grid-power flow assessment, protections and additional measurements. In this paper we just detail the droop controller for the primary frequency control and power exchange with the distribution network. First we recall the fundamental principle of the primary and secondary frequency control of the grid and then we will detail the necessary functions inside the interactive interface to adapt the operating the microgrid with the distribution network.

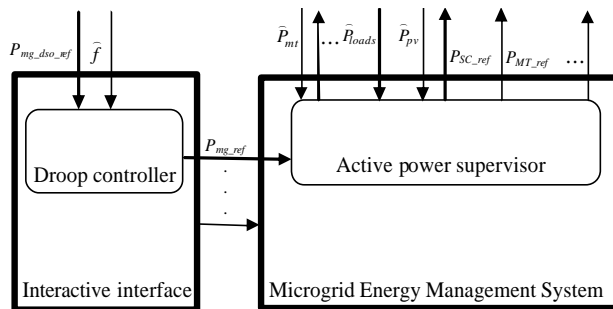

Figure 3: Implementation of the droop controller

Primary and secondary frequency control

Nowadays the synchronous operation of the conventional power plants and the power balance is maintained by the grid frequency control. Classically three steps are used to describe the control principle [2].

1) After a power variation, conventional power plants will immediately release or absorb the kinetic energy from their rotating mass: $E = \frac{1}{2} JW^2$ with J the inertia of the machine and W the rotational speed of the machine. As results, the frequency changes.

The response is determined by the equation of movement and is called inertial response, as the inertia damps the frequency deviations:

$$\frac{d\left(\frac{1}{2} JW^2\right)}{dt} = P_g - P_l \quad (1)$$

With P_g the generated power and P_l the load power.

Just after a power variation, the time evolution of the frequency is dependent on the inertia constant [3]. At this moment power plants do not contribute to frequency control.

2) When the frequency deviation exceeds a pre-defined threshold value, controllers will be activated to increase or decrease the power from the prime movers to restore the power balance. The primary frequency control contribution of the generators is based on the droop constant, which gives the additional power that is supplied as a function of the frequency deviation [6]:

$$DP_{ref} = -kDf = -k(f_0 - \hat{f}) \quad (3)$$

With f_0 the frequency in the normal operation (50 Hz for our case study), \hat{f} the sensed value of the frequency. Hence the reference of the generated power will move from the value in normal conditions P_{ref_0} to another value P_{ref_1} (fig. 4).

3) After restoration of the power balance by the primary control, the system is stable (point 2 in fig. 4) but at another frequency (f_1). The secondary frequency control brings the frequency back to its value in a normal operating (f_0) and the power operating point is changed (point 3 in fig. 4).

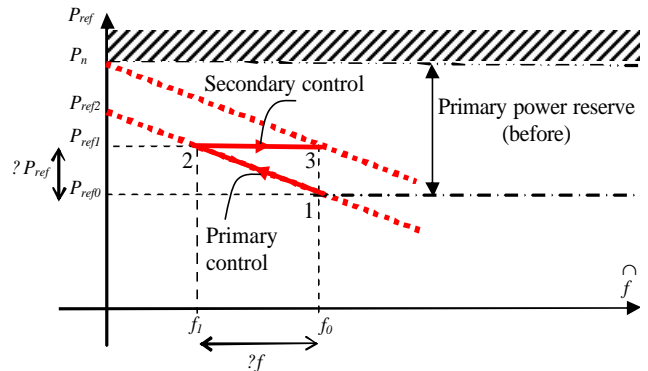

Figure 4: Idealized governor characteristic of a turbo alternator

Implementation

For our application, the DSO sends a wished power reference $P_{mg_dso_ref}$, which is considered as the exchanged power from the microgrid to the distribution network in long term (fig. 1). The classical power/frequency control principle has been derived inside the interactive interface in order to create a microgrid contribution to the primary frequency control (fig. 5). The power/frequency constant is calculated by :

$$k = \frac{1}{s} \frac{P_{mg_max}}{f_0} \quad (4)$$

With the droop: $s = 5\%$ and the maximum available power, which can be exported to the distribution network P_{mg_max} . By

extension, this quantity replace the nominal power of a conventional turbo alternator.

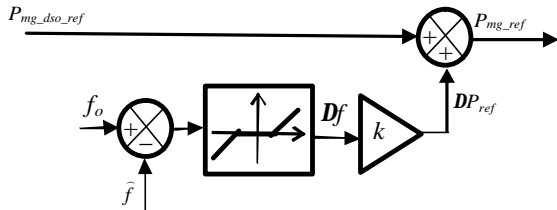

Fig. 5: Droop controller for primary frequency control

III. MICROGRID ENERGY MANAGEMENT SYSTEM

Principle

The purpose of the MEMS is to drive the three sources (fig. 2) in order to supply local loads in an optimal way for the electrical distribution and production. A great advantage of microgrids is the facility to use a communication system. Hence it makes possible to take into account more accurate informations from sources the dispatch function. For the GMT, the economic interest can be mathematically expressed as a power generation over a minimal power value. The ultra capacitors must be managed in order to smooth fast power variations resulting from loads and PV [4]. In case of low loads, PV generation should be limited to avoid a stop sequence of the GMT. Moreover a part of loads can be disconnected in case of emergency. In this paper, another function is implemented to provide the power to the distribution network so we just detail this active power supervisor.

Power supervisor

The balancing condition implies that the exchanged power has to be produced from the sources:

$$p_{mg}(t) = p_{mt}(t) + p_{pv}(t) + p_{sc}(t) - p_{Load1}(t) \quad (5)$$

With p_{mt} , the power from the GMT, p_{pv} , is the power from the photovoltaic generation system and p_{sc} is the power from ultra capacitors in generation mode.

Since the GMT has a slow dynamic response time, the MEMS uses it to provide the power for a long time range. The average power during a time range T is expressed as:

$$P = \{ p(t) \}_T = \frac{1}{T} \int_0^T p(t) dt \quad (6)$$

During such a long time range, the fast power variations exchanged with the ultra capacitors can be neglected. The power balancing condition (equ. (5)) can be rewritten as:

$$P_{mg} = \{ p_{mg}(t) \}_T = \{ p_{mt}(t) + p_{pv}(t) - p_{Load1}(t) \}_T \quad (7)$$

During such a long time range, the fast By assuming that the total load power (\hat{p}_{Load1}) and the PV generated power (\hat{p}_{pv}) are sensed and known, the power reference for the micro turbine p_{mt_ref} can be calculated by the inversion of the equation (7) as:

$$P_{mt_ref} = \{ p_{mt_ref}(t) \}_T$$

$$P_{mt_ref} = \{ p_{mg_ref}(t) - \hat{p}_{pv}(t) + \hat{p}_{Load1}(t) \}_T \quad (8)$$

The ultra capacitors have the dynamic ability to master in real time the power flow inside the microgrid. The real time power reference

for the ultra capacitor bank p_{sc_ref} can be calculated by the inversion of the equation (5) as:

$$p_{sc_ref}(t) = p_{mg_ref}(t) + \hat{p}_{Load1}(t) - \hat{p}_{pv}(t) - \hat{p}_{mt}(t) \quad (9)$$

The local control system of the ultra capacitor bank, which implements this power reference, is detailed in [5].

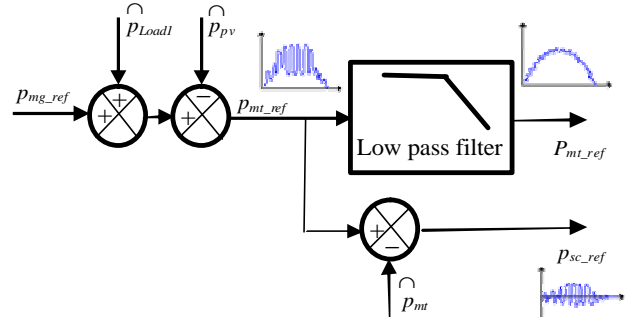

Fig. 6: Active power supervisor

IV. ANALYSIS OF A CASE STUDY

To highlight possible contributions of the microgrid we consider a load variation in the distribution network (fig. 7).

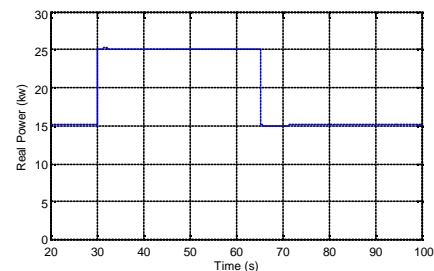

Fig. 7: P_{load2} , required power from the load2

First the microgrid is disconnected to the distribution network (K_1 is open in fig.1) and the reactive power (Q_{bhla}) is set to zero. Figures 8.a and 8.b show that the frequency variations imply a correct power production and distribution inside the network to the PCC. Currents in HTA lines (fig. 8.c) induce losses.

In a second time we consider that the micro grid is connected and that the DSO asks a spinning power reserve 20 seconds after the load transient (fig. 9.d). By comparison we can see that the frequency deviation (fig. 9.a) and the power inside the distribution network (fig. 9.b) are less. In consequence, currents in HTA lines (fig. 9.c) have been decreased.

Obtained real time variations of powers from the GMT (p_{mt}), the ultra capacitors (p_{sc}) and PV generating system (p_{pv}) are shown on fig. 9.e. Fig. 9.f shows a good contribution of the microgrid both for primary and secondary frequency control.

V. CONCLUSION

An advanced interface control system for a microgrid is presented in this paper. The droop controller for the primary frequency control and power exchange with the distribution network is detailed. Simulation results interest issues for the distribution network.

Acknowledgement

This work has been supported by the French National Agency of the Research (ANR SuperEner Project).

REFERENCES

- [1] G. Blajszczak, "Ancillary services in market environment", EPE 2003, Toulouse, France, 2 – 4 septembe 2003, CD-ROM.
- [2] S. Abu-Sharkh, "Can micro grids make a major contribution to UK energy supply ?", Renewable and Sustainable Energy Reviews 10. pp. 78–127, 2006.
- [3] J. Morren, S. W. H. de Haan, J. A. Ferreira, "Contribution of DG units to primary frequency control", European transactions on electrical power, 2006, 16, pp. 507-521.
- [4] Ph. Degobert, S. Kreuawan, P. Li, B. François, "Reduction of Fast Fluctuations of Power in a Microgrid with Super Capacitors", ESSCAP'06, CD-ROM, Lausanne, Switzerland, Nov. 2006.
- [5] P. Li, Ph. Degobert, B. François, B. Robyns, Power Control Strategy of a Photovoltaic Power Plant for Microgrid applications, ISES Solar World Congress 2007 (SWC 2007), Beijing, China, September 2007.
- [6] V. Courtecuisse, M. El Mokadem, B. Robyns, B. François, M. Petit, J. Deuse, "Association of wind turbine based dispersed generators and storage systems to participate in primary frequency control", EPE 2007, Aalborg, Denmark, 25 september, Denmark, CD-ROM

Without microgrid interactivity

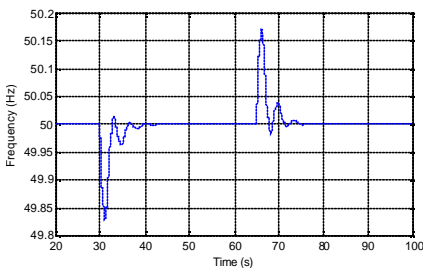

Fig. 8.a: frequency

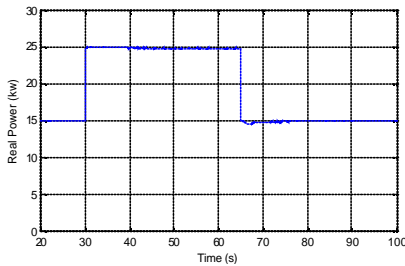

Fig. 8.b: P_{bhta}

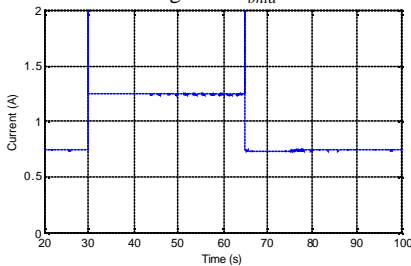

Fig. 8.c: Currents (in HTA lines)

With microgrid interactivity

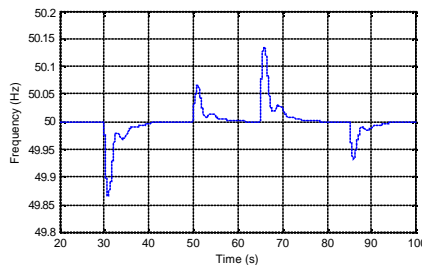

Fig. 9.a: frequency

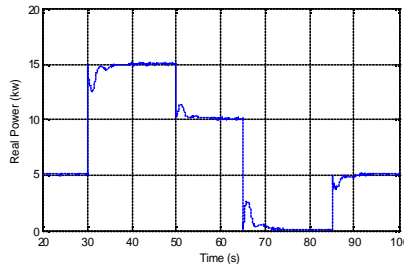

Fig. 9.b: P_{bhta}

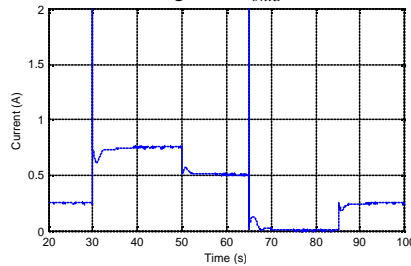

Fig. 9.c: Currents (in HTA lines)

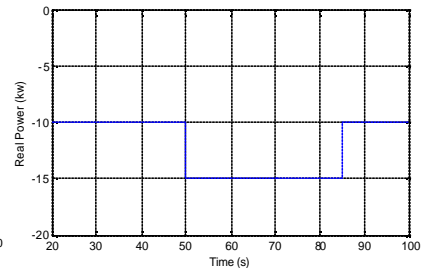

Fig. 9.d: $P_{mg_dso_ref}$

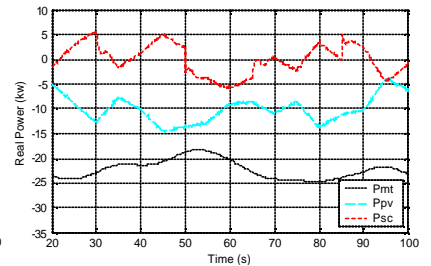

Fig. 9.e: Powers from sources inside the MG

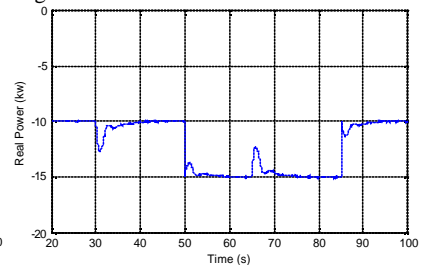

Fig. 9.f: Injected power at the PCC