

## NOVEL UNIFIED CONTROL STRATEGIES FOR SEAMLESS TRANSFER OF OPERATION OF THREE-PHASE PV-INVERTER FROM GRID-TIED TO ISLANDED MODE

Shrinath KANNAN  
IIT-M, India  
[ee16s068@ee.iitm.ac.in](mailto:ee16s068@ee.iitm.ac.in)

Rohit Kumar GNANASEKAR  
HTW-Berlin, Germany  
[s0562657@htw-berlin.de](mailto:s0562657@htw-berlin.de)

Krishna VASUDEVAN  
IIT-M, India  
[krishna@ee.iitm.ac.in](mailto:krishna@ee.iitm.ac.in)

### ABSTRACT

*In this paper, an adaptive unified control topology for seamless transfer of operation of a three-phase inverter in distributed generation systems from grid-tied to islanding mode of operation is proposed. The inverter is controlled in the synchronous reference frame and is connected to the Point of Common Coupling through an LCL filter. It is assumed that a signal indicating islanding is available. Continued operation in the island requires a method of maintaining the output voltage that avoids phase jumps and dramatic system transients. At the same time, power requirement for the load has to be met which may be varying with time. Two methods to achieve this operation are proposed which differ in the manner in which the angle of the voltage phasor generated by the inverter is arrived at. In one approach, the phase angle ( $\theta$ ) is self-determined, while in the other the phase angle transitions to an independent reference. In both approaches however, the system frequency is maintained constant at 50 Hz upon islanding. The performance of the proposed strategy in seamless transfer of operation and continuous operation of three-phase inverter in islanded mode supplying linear loads is validated through simulation and hardware.*

### INTRODUCTION

Increasing use of grid-connected renewable energy resources brings larger use of Electronically Coupled Generators (ECGs) in the grid. Typically, these ECGs are operated in grid-connected fashion and are switched off when islanding is detected. The key reason for this is safety of personnel. However, the need to operate such sources in the island is increasingly being felt as continuous operation of critical loads would result in increased utilization of local generation. Many works have been reported focusing on islanded operation. In such cases, the inverters need to transit from a grid-tied mode of operation to an islanded mode.

Literature discussing this aspect are not too many. The authors of [1-8] propose strategies to handle the transfer of operations. The systems they consider differ in the number of inverters considered and the filter structure, control strategies, transfer approach and phase angle generation. Several control strategies have been proposed by researchers for seamless transfer of operation of micro-grid connected three-phase inverters from grid tied

to islanding mode [1-8]. In these literatures [1-4], authors propose algorithms for seamless transfer of operation from grid-tied to islanded mode and have demonstrated the results for a single inverter system. Whereas, in [5-7], the authors study multiple inverter systems. In [1], a seamless transfer technique is proposed by the authors, in which, control is switched between two different structures - from current control mode to voltage control mode during the transition from grid-tied to islanded mode of operation. There is no specific effort reported to ensure continuity of phase during the transition. In [2], the authors remove an outer current loop to transit to voltage control mode during islanding, but the aspect of continuity of phase is not discussed. The wiring arrangement for the structure is also involved. The authors of [3] also address a seamless transfer problem, but details of phase continuity are not discussed. In [4], the authors store the grid phase angle and use that to transit to the islanded mode, when islanding is detected. The seamless transfer process involves complex control structure.

While LCL filter is used by [1] and many authors have shown this to be of clear advantage in grid-tie application, authors of [2-4] use an LC filter, which would not be of use in a strong grid. The control structures for these two topologies could differ widely and would need careful evaluation when seamless transfer is intended.

In [5], the authors address a two-inverter system, with a Master-Slave scheme in islanded mode. While the phase reference in islanded mode is a Master-generated sine wave, securing a smooth transition is not discussed in the paper. Droop control is used in islanded mode for load sharing in the Master, and it is important that the Master is failure proof. In [6], the authors propose droop based control for the operation of two three-phase inverters in islanded mode. The importance of transferring seamlessly, though noted, is not discussed. In [7], the authors have developed cooperative control scheme wherein three inverters are used to interfaced to a Micro-grid, in which two units are of relatively smaller power capacity compared to one large unit. However, the control algorithm is proposed based on communication among three inverters which may not always be desirable or feasible. While the filter topologies of [5-6] are not clear, [7] uses LCL filter.

In this paper, we consider PV-fed inverter using an LCL

filter to connect to the grid. Two novel methods are investigated for seamless transfer from grid-tied to islanded mode and continued operation thereafter. The basic inverter control structure used is presented in [8], and extended here for a seamless transfer to islanded mode. The two approaches investigated differ in the manner in which phase angle of the load voltage phasor is derived during transition and continued operation in islanded mode. In one, it is derived in self-oscillatory mode while in another Independent derived angle is proposed. In self-oscillatory mode, the phase angle information is derived from the PCC voltage and in Independent mode, the information is derived from an independent source.

## SYSTEM DESCRIPTION AND CONTROL TOPOLOGY

The system considered is shown in Fig. 1. The LCL filter is designed as per [9].

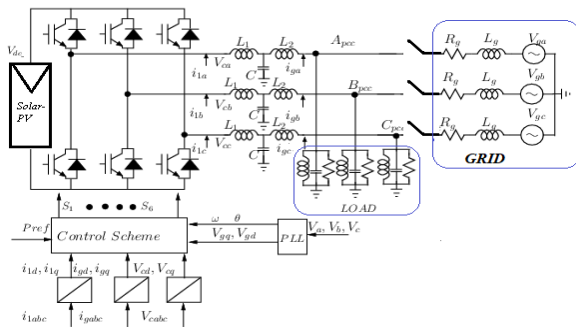

Fig 1. Grid-tied Inverter with LCL filter

### Unified Control Strategy with Voltage and Frequency Control

The control approach proposed in this work operates the inverter in the grid-tied mode as a current source and as a voltage source in islanded mode. The block diagram shown in Fig. 2 has two parts. The section highlighted in blue is a three-loop control structure for grid-tied mode of operation which is analyzed and evaluated in [8]. In grid-tied mode, the voltage loop though being part of control structure, the output of PI controller will be zero. For islanded mode of operation, the input to the outer voltage loop is changed from PCC voltage to a constant. The current reference is frozen to the same value when the islanding is detected and it continues to exist even in islanded mode. The voltage control loop ensures the load demand is met by regulating the PCC voltage to a reference values in  $dq$ -frame.

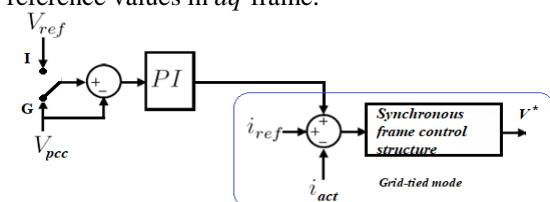

Fig 2. Control Topology for grid-tied and islanded mode of operation

## METHODS FOR PHASE CONTINUITY

### Self-Oscillatory mode

In the self-oscillatory method, the phase angle information is derived from PCC. Conventionally, the phase angle information is derived from the grid voltage before and after synchronization. From Fig. 1 it can be observed that the PCC voltage and grid voltage are the same. The phase angle information derived from grid and PCC will also be the same. Therefore, after synchronization of the inverter with the grid, the phase angle information is transferred from grid derived to PCC derived. Once the system goes into islanded mode of operation, the phase angle information is still available ensuring continuity of operation.

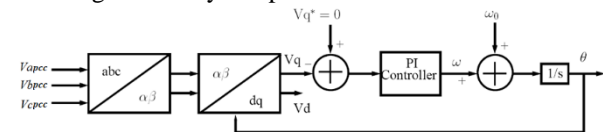

Fig. 3 Block Diagram for Self-oscillatory based seamless transfer methodology

### Independent timing mode

Timing information provided by an independent signal is used to derive phase angle information for seamless transfer of operation and operation in islanded mode. Fig. 4 shows an extension of PLL, which allows the phase angle to shift to an independent reference without causing an abrupt transition. This idea can be even extended to multiple inverter case thereby allowing all inverters operate synchronously with the time signal derived from GPS which is not feasible in Self-Oscillatory based method. Fig. 4 shows the block diagram of control structure of deriving phase angle information from an independent timing source.

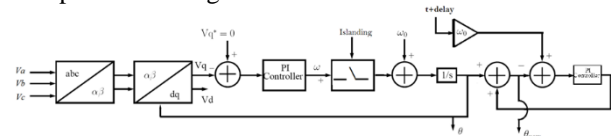

Fig. 4. Block diagram for Independent timing based methodology for deriving phase angle information

## SIMULATION AND EXPERIMENTAL RESULTS

The simulation results are shown for the Self-Oscillatory mode, and experimental results are shown for the Independent Timing Mode. However, both modes have been verified to give equivalent performances for the single inverter case in simulation and hardware. While simulation studies have been done with a PV panel model, experimental results have been obtained with a DC voltage source.

### Simulation results

The simulation results of Fig. 5 pertain to a solar PV fed inverter supplying to a grid with local loads being connected at PCC. The inverter is synchronized with the

grid at 0.3 s. Active power injection starts at 0.7 s. Islanding occurs at 1.5 s. Load demand in islanded mode changes at 2s and 2.5s. The inverter caters to the load

requirement in active and reactive powers. It can also be noted that for same irradiation, the DC bus voltage rises as load decreases and falls as load increases.

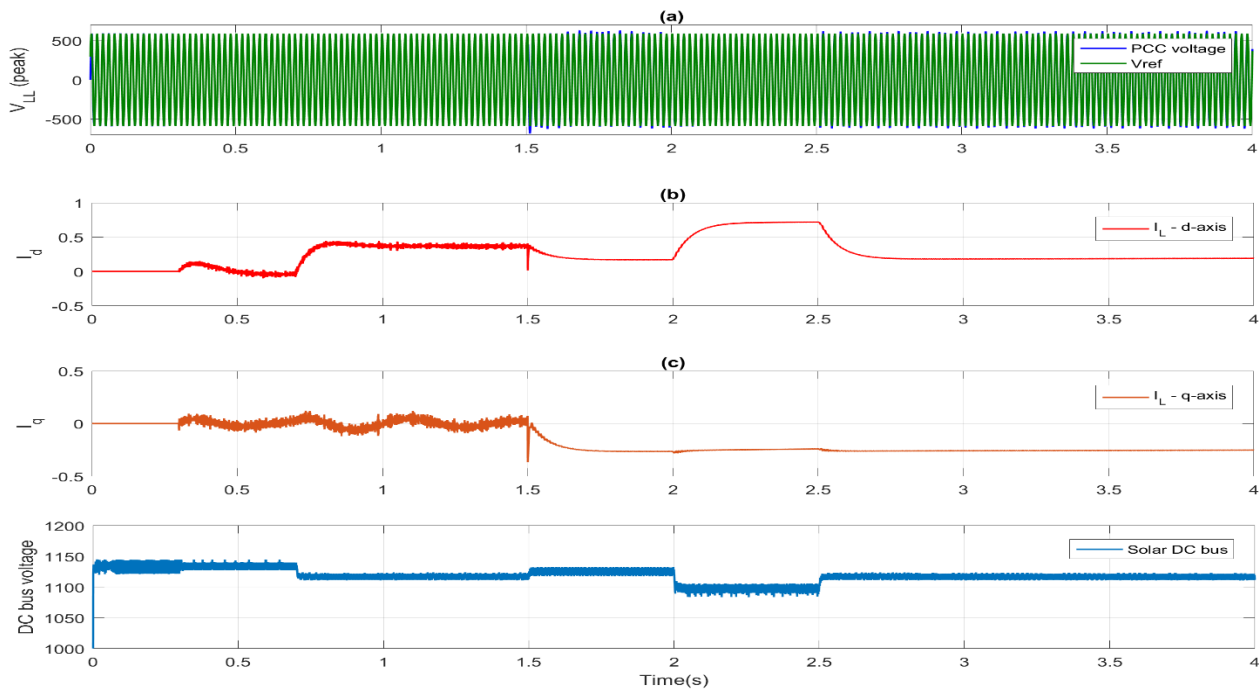

Fig. 5.(a) – PCC Line voltage (Units in Volts), (b) – d-axis current (Units in Amps), (c) – q-axis current (Units in Amps), (d) – PV voltage (Units in Volts).

### Experimental Results

The hardware setup comprises of a three-phase inverter whose DC supply is obtained from rectification of AC. The inverter is interfaced with the grid through an LCL filter. The islanding signal required to enable the voltage control loop is assumed and is coincident with the opening of the grid contactor. The control algorithm is executed through dSPACE-Microlabbox.

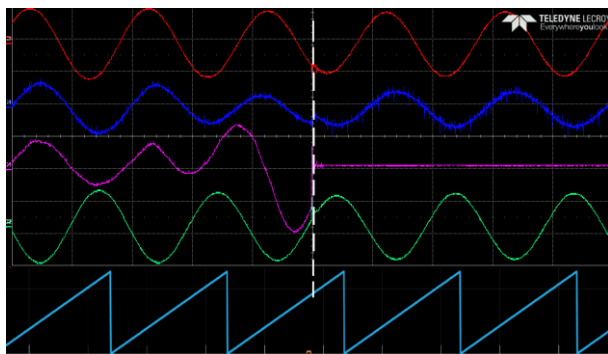

Fig. 6. Experimental results of before and after the event of seamless transfer of operation from grid-tied to islanded mode: Red-PCC Voltage (100V/div), Blue-Inverter current (1A/div), Pink – grid current (500mA/div), Green-load current(1A/div), teal-phase angle information. Time – 10ms/div

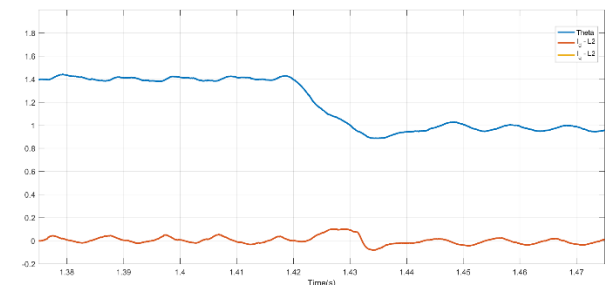

Fig. 7. Experimental results of before and after the event of seamless transfer of operation from grid-tied to islanded mode: blue – d-axis current of inverter (units in Amps), red- q-axis current of inverter (units in Amps) (via dSPACE-Controldesk).

The experimental results from Fig. 6 through Fig. 8 present the waveforms during the transfer of operation from grid-tied to islanded mode. In Fig. 7 and Fig. 8 the system changes its mode of operation from grid-tied to islanded mode at 1.42s. As it can be seen from Fig. 6, the load demand is met by the inverter after the transfer of operation to islanded mode. It can also be seen from Fig. 6 and Fig. 8 the PCC voltage does not show any dramatic transients during and after the transition. This indicates the correct operation of the seamless transfer. From Fig. 9 and Fig. 10 it can be seen that the inverter meets a step change in load demand. The voltage at PCC remains constant during the change in load demand. This evaluates the performance of the voltage control loop.

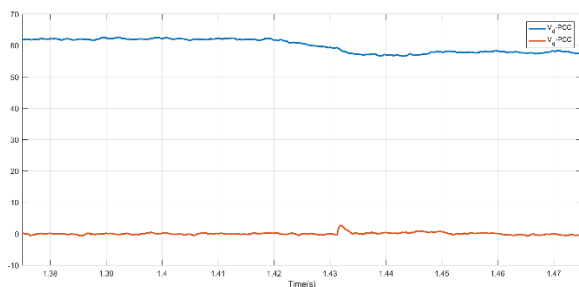

Fig. 8. Experimental results of before and after the event of seamless transfer of operation from grid-tied to islanded mode: blue – d-axis voltage at PCC (Units in Volts), red- q-axis voltage at PCC (via dSPACE-Controldesk).

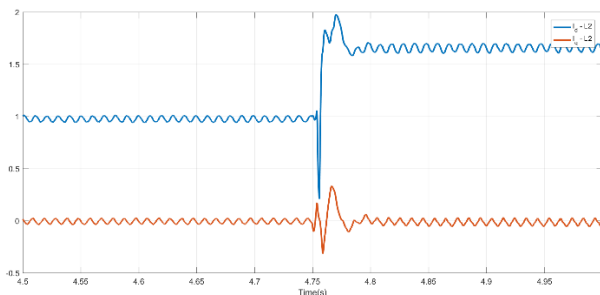

Fig. 9. Experimental results of load change in islanded mode of operation: blue – d-axis current of inverter (units in Amps), red- q-axis current of inverter (units in Amps), (via dSPACE-Controldesk).

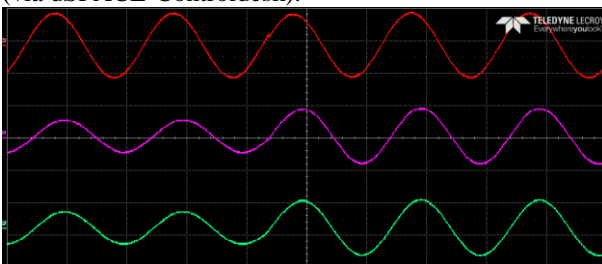

Fig. 10. Experimental results of load change in islanded mode of operation: Red- voltage at PCC (100V/div), Pink-Inverter current (2A/div), Green-load current (2A/div). Time – 10ms/div.

## CONCLUSION

In this paper two novel methodologies for seamless transfer from grid-tied to islanded mode were proposed. From the simulation and experimental results, it can be seen that both self-oscillatory and Independent Timing Mode perform with good transient performance during the transfer of mode of operation. The voltage control loop effectively maintains the PCC voltage constant when load demand changes during islanded mode of operation. However, it is to be noted that self-oscillatory method cannot be extended to multiple inverter in islanded mode of operation in micro-grid because it would result in circulating currents among the inverters and causing disproportionate load sharing. The Independent timing approach on the other hand, is a suitable candidate for multiple inverter cases as well.

## ACKNOWLEDGMENT

The authors would like to acknowledge the support from **Maschinenfabrik Reinhausen**, Regensburg, Germany through the IGCS Research Programme on Sustainable Power Engineering.

## REFERENCES

- [1] T. V. Tran, T. W. Chun, H. H. Lee, H. G. Kim and E. C. Nho, 2014, "PLL-Based Seamless Transfer Control Between Grid-Connected and Islanding Modes in Grid-Connected Inverters," *IEEE Transactions on Power Electronics*, vol. 29, no. 10, pp. 5218-5228.
- [2] Z. Liu and J. Liu, 2014, "Indirect current control based seamless transfer of three-phase inverter in distributed generation," *IEEE Transactions on Power Electronics*, vol. 29, no. 7, pp. 3368–3383.
- [3] Z. Guo, D. Sha, and X. Liao, 2014, "Voltage magnitude and frequency control of three-phase voltage source inverter for seamless transfer," *IET Power Electronics*, vol. 7, no. 1, pp. 200–208.
- [4] X. Li, H. Zhang and R. Balog, 2015 "Control strategy for seamless transfer between island and grid-connected operation for a dual-mode photovoltaic inverter," *IEEE Energy Conversion Congress and Exposition (ECCE), Montreal, QC*, pp. 5983-5990.
- [5] H. Laaksonen, P. Saari, and R. Komulainen, 2005 "Voltage and frequency control of inverter based weak lv network microgrid", *International Conference on Future Power Systems*, pp.–6.
- [6] J. M. Guerrero, N. Berbel, J. Matas, J. L. Sosa, and L. G. de Vicuna, 2007, "Droop control method with virtual output impedance for parallel operation of uninterruptible power supply systems in a microgrid," *APEC 07 - Twenty-Second Annual IEEE Applied Power Electronics Conference and Exposition*, pp. 1126–1132.
- [7] C. Wang, B. Liang and J. He, 2017, "An Enhanced Power Regulation and Seamless Operation Mode Transfer Control through Cooperative Dual-Interfacing Converters," *IEEE Transactions on Smart Grid*, vol. PP, no. 99, pp. 1-1.
- [8] D. Sivadas and K. Vasudevan, 2016, "Stability analysis of three-loop control for three phase voltage source inverter interfacing to the grid based on state variable estimation," *IEEE International Conference on Power Electronics, Drives and Energy Systems (PEDES)*, pp. 1–6.
- [9] C. Poongothai and K. Vasudevan, 2016, "Design of LCL filter for grid-interfaced PV system based on cost minimization", *IEEE International Conference on Power Electronics, Drives and Energy Systems (PEDES)*, pp. 1–6.