

## RELIABILITY EVALUATION OF GRID-CONNECTED MICROGRIDS WITH HIGH PENETRATION OF RENEWABLE DISTRIBUTED ENERGY RESOURCES

Alberto ESCALERA  
IMDEA Energy – Spain  
Univ. Carlos III de Madrid – Spain  
alberto.escalera@imdea.org

Milan PRODANOVIC, Rodrigo SEGOVIA  
IMDEA Energy – Spain  
milan.prodanovic@imdea.org

Edgardo D. CASTRONUOVO  
Univ. Carlos III de Madrid – Spain  
ecastron@ing.uc3m.es

### ABSTRACT

*Creation of microgrids in distribution networks under fault conditions is a well-known solution for improving network reliability. In order to provide operation in islanded mode, microgrids require advance control functionalities and an adequate level of distributed energy resources. However, variable renewable generation introduces several constraints with respect to possible network reliability improvements to the microgrid approach. This paper addresses these constraints and evaluates the options for reliability improvement of microgrids with high presence of renewable generation. Load shedding, energy storage, distributed generation and creation of smaller microgrids within a microgrid are all evaluated. The reliability improvements of these solutions were demonstrated by using an 11 kV island microgrid connected to a wider mainland network. The evaluation results identified the further opportunities for the supply reliability improvements in microgrids based on renewable and storage technologies.*

### INTRODUCTION

Radial power distribution networks in rural areas or islands are exposed to failures that may provoke long and sustained customer supply interruptions. These failures create isolated areas if there are no alternative solutions installed to restore the supply. Creation of microgrids connected to distribution networks is a proven solution to restore the supply in the areas isolated by faults [1]. Unlike typical distribution networks, microgrids assume an installation of advance control solutions to permit their autonomous operation in islanded mode with distributed energy connected. Under normal conditions, microgrids operate connected to the network in order to minimize the cost of the energy supply and, if the grid-supply is interrupted, microgrids operate in the islanded mode. This allows the customers within the microgrid, instead of being interrupted, to be restored (or even uninterrupted throughout the fault) resulting in their improved reliability indices [2].

Moreover, microgrids in rural areas or islands often rely on the locally integrated renewable energy sources [3]. The renewable generation can be used not only for the improvement of efficiency and sustainability of the system, but also for the improvement of customer reliability of supply. However, some of the resources like wind and solar exhibit fluctuations and increased levels of uncertainties that limit the capacity of microgrids to operate in islanded mode. Integration of

energy storage and load shedding technologies has proven to be successful in managing fluctuations of renewable energy in microgrids, and represents a valuable tool in supporting the restoration [2]. The capacity of these solutions for the reliability improvement needs to be adequately evaluated to confirm if they may act as an alternative to conventional generation backup.

Reliability evaluation of microgrids typically includes the variability of renewable generation and load. An adequacy assessment was performed in [4], [5]. In addition to renewable generation, application of load shedding in the microgrids was evaluated in [6], [7], while the impact of energy storage was addressed in [8], [9]. Topology of the microgrid was also discussed in [10] by evaluating the component failures inside of the microgrid. These failures can create smaller microgrids (or sub-microgrids) in the case Distributed Generation (DG) is installed and enabled to operate in islanded mode.

All the previous options represent possible solutions for the reliability improvement in microgrids with high penetration of renewable generation, and this paper proposes a novel methodology to provide their evaluation. The evaluated options are: a) variable renewable generation, b) energy storage and load shedding as solutions for generation variability, and c) sub-microgrids with DG units that operate in islanded mode when faults occur inside the main microgrid. An analysis is performed for a MV distribution network that supplies the power of an island connected to mainland via a submarine cable. In this analysis, the options proposed to improve the reliability of the island are compared and discussed.

The paper is organized as follows: firstly, the methodology for the reliability improvement in microgrids is proposed and the method used to assess the reliability described. Then, the case study is introduced and the results presented. Finally, conclusions are drawn.

### METHODOLOGY

The proposed methodology evaluates the reliability improvement introduced by the creation of microgrids with high presence of renewable generation. Variability of renewable generation during the supply restoration is dealt with by the integration of load shedding and energy storage technologies.

The proposed methodology permits the reliability evaluation of the following cases:

- 1) Distribution networks where islanded operation is not permitted under fault conditions
- 2) Microgrids capable of operating in islanded mode

during fault conditions that include high-share of renewable generation

- 3) The same as case 2) but with energy storage and load shedding technologies installed to mitigate the generation shortages (and excesses)
- 4) Microgrids with dispersed distributed energy resources that permit the creation of sub-microgrids when a fault occurs

The results obtained by evaluating these cases can be compared and used to determine if the scenarios based on high-penetration of renewable generation are an effective solution for the reliability improvement.

## RELIABILITY ASSESSMENT METHOD

The reliability improvement in microgrids can be defined as the capacity to provide the supply during the operation in islanded mode. During this time variability of renewable generation and load are chronologically assessed, while remedial actions based on the use of energy storage and load shedding support moments of generation shortages. In this way, the restoration feasibility is extended.

For the evaluation of these features in microgrids, a reliability assessment method based on sequential Monte Carlo simulation is used in this paper. This approach permits the chronological probabilistic evaluation of a) renewable generation and demand variability during a fault [11], b) energy storage performance (charge and discharge) [8].

Component failures in the network are randomly sampled using probability distributions as in [12]. The failure rate of the components is assumed to follow an exponential distribution, while repair times are based on average statistical values as in [11]. Two states are considered for the components: failure and operation.

Each time a component failure is sampled, the load points affected by the failures are identified and the impact on the supply quantified. The zone branch methodology in [13] is used to simulate the operation of protection devices and to evaluate the areas of the network affected by the fault. This procedure is repeated for every component failure until a specific interval of confidence is achieved (a 2 % in this paper) [12]. Then, the reliability indices are calculated in the form of average values and probability distributions as in [12].

Average values of area indices SAIFI (System Average Interruption Frequency Index), SAIDI (System Average Interruption Duration Index), ENS (Energy Not Supplied) and ECOST (Interruption Cost) are calculated by using [12].

The area indices are obtained from the reliability indices of the load points, whose average values are calculated as [12]:

$$\lambda_i = \frac{N_i}{\sum_{j=1}^{N_i} Tu_j}; r_i = \frac{\sum_{j=1}^{N_i} Td_j}{N_i}; U_i = \frac{\sum_{j=1}^{N_i} Td_j}{\sum_{j=1}^{N_i} (Tu_j + Td_j)} \quad (1)$$

where  $\lambda_i$ ,  $r_i$  and  $U_i$  are the failure rate, outage duration and annual unavailability of load point  $i$ ,  $N_i$  is the

number of interruptions in load point  $i$  during the sampled years, and  $Tu_j$  and  $Td_j$  are the up (u) and down (d) times in load point  $i$  caused by fault  $j$ .

## Restoration evaluation in microgrids

If the input supply of a microgrid is interrupted, the existing resources in the microgrid can be used to supply its load and reduce the number and duration of the interruptions. The reduction depends on the capacity of the resources, and their probabilistic evaluation is required to determine the reliability indices.

The capacity of the microgrids to restore the supply is evaluated during the time in which they are isolated from the main supply. In this time interval, a thorough analysis of generation-demand adequacy is performed. The adequacy assessment takes into consideration:

- variability of renewable DG
- non-critical loads that can be shed
- energy that can be provided by energy storage during the moments of generation shortage

## Renewable generation evaluation

Variability of renewable generation may provoke generation shortages that constrain the restoration capacity of microgrids. Thus, the adequacy assessment considers the chronological evolution of renewable generation and demand during the fault, including their fluctuations. Since reliability indices refer to an annual time horizon, hourly profiles of a whole year are used to model the variable renewable power and the load. In addition to the availability of renewable resources, the availability of generation units is modelled considering their Forced Outage Rate [12].

The supply is restored only in those time intervals when generation is larger than demand. Moreover, the restoration strategy avoids repetitive restoration and interruption processes, a likely case in presence of renewable power. For this reason, or restorations are sustained over several hours (for example, at least 10 hours), or only one interruption is permitted per fault.

## Energy storage evaluation

During fault conditions, the proposed method models the operation of energy storage that supports generation variability, and evaluates its capacity to extend the supply restoration. The storage performance is evaluated for each hour over the fault duration as in [9], including generation shortages and excesses leading to discharge and charge periods. The restrictions in the number of repetitive interruptions (previously described in *Renewable generation evaluation* section) also apply to energy storage evaluation.

The chronological state of charge (SOC) including both charges and discharges during the fault is modelled as:

$$SOC(t + 1) = SOC(t) + \left( P_{char} \eta_{char} - \frac{P_{dis}}{\eta_{dis}} \right) \Delta t \quad (2)$$

where  $P_{char}$  and  $P_{dis}$  are charge and discharge powers,  $\eta_{char}$  and  $\eta_{dis}$  are the efficiencies of charge and

discharge and  $\Delta t$  is the duration of the evaluated time step (for example, 1 hour).

Operational limits of energy storage (state of charge and rated power) are also considered and storage is assumed to be fully charged when the fault occurs.

### Load shedding evaluation

In addition to energy storage, load shedding is another solution evaluated for generation and demand adequacy. Load points in the microgrid equipped with load shedding functionality are recursively disconnected until adequacy is obtained. The loads with lower priority are disconnected first. Binary load shedding is applied as there are two possible states for a load point: connected and disconnected.

### Reliability assessment of sub-microgrids

Component failures inside the microgrid are also included in the reliability assessment. These failures can create isolated areas within the microgrid. If these areas include distributed energy resources and are equipped to operate in islanded mode, they are considered for the supply restoration and reliability improvement.

The proposed method assesses the reliability improvement introduced by these sub-microgrids. In a similar way to microgrids, the restoration capability of distributed energy resources is evaluated and the contribution to the reliability indices quantified.

## CASE STUDY

### Test Network

The methodology proposed in this paper was used to evaluate the possible reliability improvement of a real 11 kV network depicted in Figure 1. The network corresponds to the distribution system of an island in the north of Europe. It is connected to the mainland system via a 1 kilometre submarine cable of 2.5 MVA.

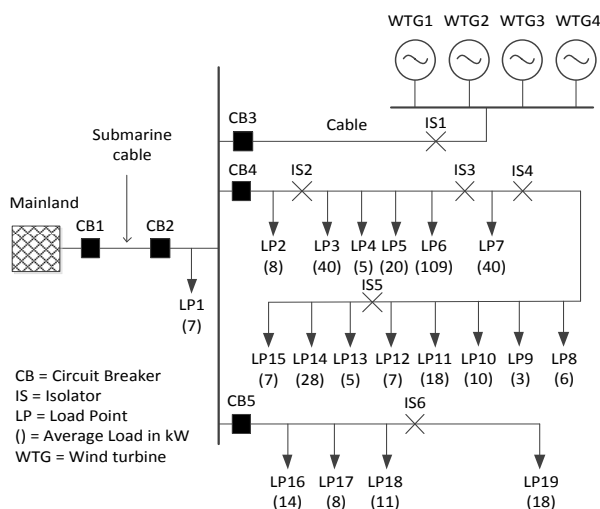

Figure 1. Single-line diagram of the island network

If a fault occurs in the mainland system or in the submarine cable, the supply is interrupted as the network is currently not prepared to operate in an

islanded microgrid mode.

The network integrates four wind turbines generators (WTG1-WTG4) that are currently disconnected when the island system is isolated from the mainland system. Rated power of each WTG is 225 kW.

Failure statistics for the 11 kV aerial lines, the cable and secondary substations were obtained from ENA report in [14]. The submarine cable had a failure rate of 0.051 failures/year and an average repair time of 120 hours, while the fault characteristics of the mainland grid were unknown and, therefore, neglected in this study. This means that the reliability indices were underestimated. Operation of the protection devices was assumed to be fully reliable with switching times of 1 hour. Hourly profiles of one representative year were used for renewable resources and load. Data of renewable resources were obtained from the island location, while data of load profiles were obtained from [15]. Three types of customers existed in the network: industrial (load points 6-8 and 18), residential (load points 1-5, 9-11, 13-14, 16-17 and 19) and farms (load points 12 and 15). Interruption costs in [12] were used in the study. The reliability indices of the original network are shown in Table 1.

Table 1. Reliability indices of the test network

SAIFI (failures/year)	SAIDI (hours/year)	ENS (MWh/year)	ECOST (k€/year)
0.73	10.29	3.58	15.38

### Scenarios for reliability improvement

In order to improve the reliability of the original test network, the following cases were evaluated:

#### Scenario 1 – Wind Microgrid:

The distribution system of the island (downstream the submarine cable) was equipped to operate as an islanded microgrid. The control system, inverters and protection devices were assumed to be equipped to support this functionality. The circuit breakers and the disconnector IS4 were telecontrolled (switching time of 10 minutes).

The power was supplied by the wind turbines operated in islanded mode. Load shedding functionality was applied in load points 2, 5, 10, 12, 15 and 17. Conventional generation was assumed to be used to provide the stability of the island microgrid.

#### Scenario 2 – Wind Microgrid + Storage:

This scenario was similar to Scenario 1 but an energy storage (redox flow battery) was added next to the four wind turbines. The size and the parameters of the energy storage are shown in Table 2.

Table 2. Parameters of the energy storage

Capacity (MWh)	Power (kW)	$\eta_c, \eta_d$	SOCmin	SOCmax
1.25	105	0.8	0.1	1

#### Scenario 3 – Sub-microgrids + Scenario2:

The network in Scenario 2 was extended in order to



allow the creation of sub-microgrids inside of the islanded microgrid. The sub-microgrids were supplied by the DG units specified in Table 3.

Four levels of DG penetration were evaluated: *Lev 1*, *2xLev 1*, *3xLev 1* and *4xLev 1*. Rated powers in Table 3 correspond to *Lev 1*, while the power in the other levels was 2, 3 and 4 times larger than *Lev 1*.

Table 3. DG units introduced in the test network

DG unit	Location	Type	Power Lev 1 (kW)
DG 1	LP 4	Wind	68.3
DG 2	LP 9	Wind	22.5
DG 3	LP 11	Solar	12.5
DG 4	LP 14	Wind	19.3
DG 5	LP 18	Wind	15
DG 6	LP 19	Solar	7.5

## Results

Reliability was evaluated for the three proposed scenarios and the results of the reliability indices SAIDI and ECOST for the test network are shown in Figure 2.

The results showed that Scenario 1 (microgrid that includes wind turbines WTG1-WTG4 and load shedding) negligibly improved the supply reliability (< 1 %). The wind generation and its shortages failed to provide any sustained restoration periods.

Integration of energy storage in Scenario 2 improved SAIDI from 10.3 to 9.1 hours/year and the energy-not-supplied cost (ECOST) from 15.3 to 12.8 k€/year. These results demonstrated the capacity of energy storage to improve the test network reliability in presence of variable renewable generation.

The most significant reliability improvement was obtained at DG penetration levels *Lev 1* and *2xLev 1* in Scenario 3 (scenario that included the creation of sub-microgrids). *Lev 1* reduced SAIDI to 7.4 hours/year and ECOST to 9.5 k€/year, while the same reliability indices decreased to 5.9 hours/year and 6.6 k€/year respectively in *2xLev 1*.

However, increasing the DG capacity to *3xLev 1* and *4xLev 1* caused additional reliability improvements yet significantly smaller than those obtained for *Lev 1* and *2xLev 1*. It can be concluded that the creation of sub-microgrids significantly improves the test network reliability but it is highly dependent and sensitive on the locally installed DG penetration level.

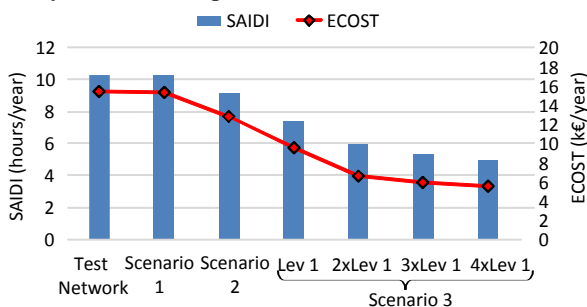

Figure 2. SAIDI and ECOST reliability indices obtained for the test scenarios

## CONCLUSIONS

This paper presents a novel and integrated methodology for reliability evaluation of microgrids with high penetration of renewable generation, load shedding, energy storage and islanded operation of sub-microgrids within microgrids. A sequential Monte Carlo simulation technique was used to evaluate the reliability improvement introduced by all these solutions. A case study based on a real island network connected to mainland was used to demonstrate the proposed methodology and its effectiveness.

The obtained results showed that variability of renewable generation hinders any reliability improvements in microgrids and that load shedding technology only is not sufficient to support supply restoration. However, energy storage integration helps significantly to deal with the fluctuation of generation and demand. Further reliability improvements can be obtained by allowing restoration through sub-microgrids created within microgrids.

## REFERENCES

- [1] R. H. Lasseter, "Microgrids and Distributed Generation," *J. Energy Eng.*, vol. 133, no. 3, pp. 144–149, Sep. 2007.
- [2] N. N. A. Bakar, M. Y. Hassan, M. F. Sulaima, M. N. im Mohd Nasir, and A. Khamis, "Microgrid and load shedding scheme during islanded mode: A review," *Renewable and Sustainable Energy Reviews*, vol. 71, Pergamon, pp. 161–169, 01-May-2017.
- [3] J. Tollefson, "Energy: Islands of light," *Nature*, 2014.
- [4] M. Al-Muhaini and G. T. Heydt, "Evaluating future power distribution system reliability including distributed generation," *IEEE Trans. Power Deliv.*, vol. 28, no. 4, pp. 2264–2272, 2013.
- [5] S. Conti and S. A. Rizzo, "Modelling of microgrid-renewable generators accounting for power-output correlation," *IEEE Trans. Power Deliv.*, vol. 28, no. 4, pp. 2124–2133, 2013.
- [6] In-Su Bae and Jin-O Kim, "Reliability Evaluation of Customers in a Microgrid," *IEEE Trans. Power Syst.*, vol. 23, no. 3, pp. 1416–1422, Aug. 2008.
- [7] S. Conti, R. Nicolosi, and S. A. Rizzo, "Generalized Systematic Approach to Assess Distribution System Reliability With Renewable Distributed Generators and Microgrids," *IEEE Trans. Power Deliv.*, vol. 27, no. 1, pp. 261–270, Jan. 2012.
- [8] Y. Xu and C. Singh, "Adequacy and Economy Analysis of Distribution Systems Integrated With Electric Energy Storage and Renewable Energy Resources," *IEEE Trans. Power Syst.*, vol. 27, no. 4, pp. 2332–2341, Nov. 2012.
- [9] A. Escalera, B. Hayes, and M. Prodanovic, "Analytical method to assess the impact of distributed generation and energy storage on reliability of supply," *CIRED - Open Access Proc. J.*, vol. 2017, no. 1, pp. 2092–2096, 2017.
- [10] Z. Bie, P. Zhang, S. Member, G. Li, B. Hua, M. Meehan, and X. Wang, "Reliability Evaluation of Active Distribution Systems Including Microgrids," *IEEE Trans. Power Syst.*, vol. 27, no. 4, pp. 2342–2350, 2012.
- [11] R. Billinton and P. Wang, "Teaching Distribution System Reliability Evaluation Using Monte Carlo Simulation," *IEEE Transactions on Power Systems*, vol. 14, no. 2, pp. 397–403, 1999.
- [12] R. Billinton and L. Wenyuan, *Reliability Assessment of Electric Power Systems Using Monte Carlo Simulation*, 1st ed. New York, 1994.
- [13] A. A. Chowdhury and D. O. Koval, *Power Distribution System Reliability*. New Jersey: John Wiley & Sons, Inc., 2009.
- [14] National Fault and Interruption Reporting Scheme, "National system and equipment performance," 2010.
- [15] "European commission SmartHG project website," <http://smarthg.di.uniroma1.it/>.